



**BALTIMORE  
AIRCOIL COMPANY**



**PT2**

# **PT2 Cooling Tower**

**RIGGING & ASSEMBLY INSTRUCTIONS**



**PT2 Cooling Towers should be rigged and assembled as outlined in this manual.**

These procedures should be thoroughly reviewed prior to the actual rigging and assembly of the equipment to acquaint all personnel with procedures to be followed and to ensure that all necessary equipment will be available beforehand. If outstanding circumstances require a departure from the procedures outlined in this manual, contact your local BAC Representative for guidance.



Be sure to have a copy of the submittal drawings available for reference. If you do not have a copy of these drawings, or if you need additional information about this unit, contact your local BAC Representative whose name and telephone number are on the outside of the cold water basin. The model number and serial number of the unit are also located in this area.



# Table of Contents

## RIGGING & ASSEMBLY INSTRUCTIONS » PT2 COOLING TOWER

### 1 Introduction

---

- 2 Safety
- 2 Shipping
- 2 Pre-Rigging Checks
- 3 Cold Weather Operation
- 3 Location
- 3 Warranties
- 3 Unit Operation

### 2 Unit Rigging & Assembly

---

- 4 Rigging
- 5 Section Assembly of Two-Piece Cells
- 5 Section Assembly of Optional Three-Piece Cells
- 6 Rigging of Containerized Units
- 6 Multi-Cell Unit Installation
- 9 Motor Installation for PT2-0709, PT2-0809, PT2-0812, and PT2-0814
- 10 Fan Guard Installation

### 3 Optional Accessory Installation

---

- 12 Side Outlet Depressed Sump Box
- 13 Bottom Water Outlet
- 14 Fan Cowl Extensions
- 14 Discharge Sound Attenuation (PT2-0412)
- 15 Motor Removal Davit
- 16 Inclined Access Ladder
- 18 Mechanical Access Platform
- 28 Mechanical Access Platform Ladder
- 31 Ladder Safety Cage
- 32 Automatic Bearing Greasers
- 32 Basin Accessories
- 32 Heater Control Panel

# 1 Introduction

**WARNING:** Failure to use lifting provisions can result in a dropped load causing severe injury, death, and/or property damage. Lifts must be performed by qualified riggers following BAC published Rigging Instructions, and generally accepted lifting practices. The use of a supplemental safety sling may also be required if the lift circumstances warrant its use, as determined by the rigging contractor.

**CAUTION:** Only personnel qualified to do so should undertake the installation, operation, maintenance, and repair of this equipment. Proper care, procedures, and tools must be used in handling, lifting, installing, operating, maintaining, and repairing this equipment to prevent personal injury and/or property damage.



## Safety

Adequate precautions appropriate for the installation and location of these products should be taken to safeguard the equipment and the premises from damage and the public from possible injury. **The procedures listed in this manual must be thoroughly reviewed prior to rigging and assembly. Read all warnings, cautions, and notes detailed in the margins.**

When the fan speed of the unit is to be changed from the factory set speed, including the use of a variable speed device, steps must be taken to avoid operating at or near the fan's "critical speed" which could result in fan failure and possible injury or damage. Consult with your local BAC Representative on any such applications.

## Shipping

BAC PT2 Cooling Towers are factory assembled to ensure uniform quality with minimum field assembly. As standard, models ship in two sections per cell (lower and upper). Optional shipment of three sections per cell and optional containerized shipments are available. Contact your local BAC Representative for more information. For the dimensions and weights of a specific unit or section, refer to the submittal drawings.

## Pre-Rigging Checks

When the unit is delivered to the jobsite, it should be checked thoroughly to ensure all required items have been received and are free of any shipping damage prior to signing the bill of lading.

### The following parts should be inspected:

- Sheaves and Belts
- Bearings
- Bearing Supports
- Fan Motor(s)
- Fan Guard(s)
- Fan(s) and Fan Shaft(s)
- Float Valve Assembly(s)
- Fill
- Water Distribution System
- Cold Water Basin Accessories
- Interior Surfaces
- Exterior Surfaces
- Louvers
- Mating Surfaces Between Sections/Modules
- Miscellaneous Items: All bolts, nuts, washers, and sealer tape required to assemble sections or component parts are furnished by BAC and shipped with the unit. A checklist inside the envelope marked "Customer Information Packet" indicates what miscellaneous parts are included with the shipment and where they are packed. This envelope will be attached to the side of the unit or located in a box inside the unit.



## Introduction

### Safety

### Shipping

### Pre-Rigging Checks

Unit Weights

Anchoring

### Cold Weather Operation

### Location

### Warranties



**NOTICE:** Before an actual lift is undertaken, ensure no water, snow, ice, or debris has collected in the basin or elsewhere in the unit. Such accumulations will add substantially to the equipment's lifting weight.

## Unit Weights

Before rigging any unit, the weight of each section should be verified from the unit submittal drawing. Unit print weights include the final assembled tower with all accessories. Accessory weights (found on the respective drawing) can be deducted from the total weight.

## Anchoring

Seven-eighths inch (7/8") diameter holes are provided in the bottom flange of the basin section for bolting the unit to the support beams. Refer to the suggested support drawing included in the submittal for location and quantity of the mounting holes. **The unit must be level for proper operation.** Anchor bolts must be provided by others. The IBC rating is only certified with standard anchorage locations. Using alternate anchorage locations or alternate steel supports will void any IBC wind or seismic ratings. Contact your local BAC Representative for details.

## Cold Weather Operation

These products must be protected by mechanical and operational methods against damage and/or reduced effectiveness during sub-freezing temperatures. Please refer to the *Common Operation & Maintenance Manual* available at [www.BaltimoreAircoil.com](http://www.BaltimoreAircoil.com), or contact your local BAC Representative for recommended cold weather operation strategies.

## Location

All evaporative cooling equipment must be located to ensure an adequate supply of fresh air to the fans. When units are located adjacent to walls or in enclosures, care must be taken to ensure the warm, saturated, discharge air is not deflected and recirculated back to the air intakes.

Each unit must be located and positioned to prevent the introduction of discharge air into the ventilation systems of the building on which the unit is located and of adjacent buildings. For detailed recommendation on BAC equipment layout, see our website at [www.BaltimoreAircoil.com](http://www.BaltimoreAircoil.com) or contact your local BAC Representative.

## Warranties

Please refer to the Limitation of Warranties (located in the submittal package) applicable to and in effect at the time of the sale/purchase of these products.

## Unit Operation

Prior to start-up and unit operation, refer to the *PT2 Operation & Maintenance Manual* shipped with the unit and also available at [www.BaltimoreAircoil.com](http://www.BaltimoreAircoil.com)

# 2

## PT2 COOLING TOWER

# Unit Rigging & Assembly

**WARNING:** Failure to use lifting provisions can result in a dropped load causing severe injury, death, and/or property damage. Lifts must be performed by qualified riggers following BAC published Rigging Instructions, and generally accepted lifting practices. The use of a supplemental safety sling may also be required if the lift circumstances warrant its use, as determined by the rigging contractor.

**NOTE:** For weight information, refer to the submittal drawing package.



### Rigging

Refer to **Table 1** for the recommended vertical dimension “H” from the lifting device to the spreader bar. In the event of extended lifts or where hazards exist, the lifting devices should be used in conjunction with safety slings placed under the unit.

Model Number	W (Length of Spreader Bar)	H (Distance From Lift Point to Lifting Device)			
		Lower Section	Two-Piece Lift	Three-Piece Lift	
			Upper Section/ Single-Piece Lift	Middle Section	Upper Section
PT2-0412	4'	16'	8'	8'	8'
PT2-0709	7' 4"	14'	10'	10'	10'
PT2-0809	8' 6"	14'	12'	12'	12'
PT2-0812	8' 6"	16'	12'	12'	12'
PT2-0814	8' 6"	16'	12'	12'	12'
PT2-1009	10'	14'	14'	14'	14'
PT2-1012	10'	16'	14'	14'	14'
PT2-1212	12'	16'	16'	16'	16'
PT2-1214	12'	18'	18'	18'	18'
PT2-1218	12'	18'	18'	18'	18'

Table 1. Minimum Vertical Dimension and Spreader Bar Length

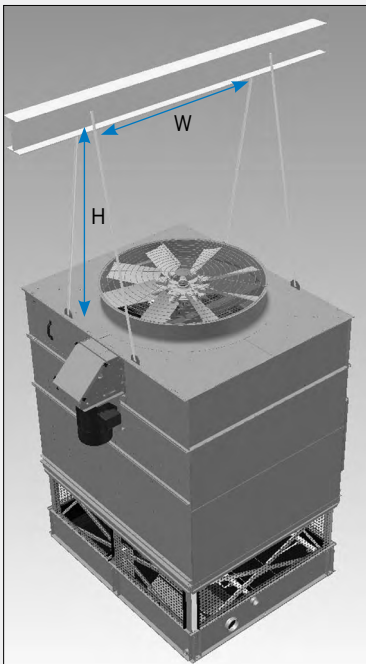

Figure 1. Single-Piece Lift

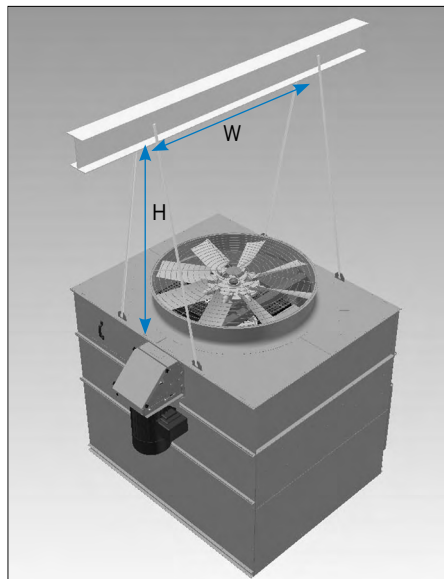

Figure 2. Upper Section Two-Piece Lift

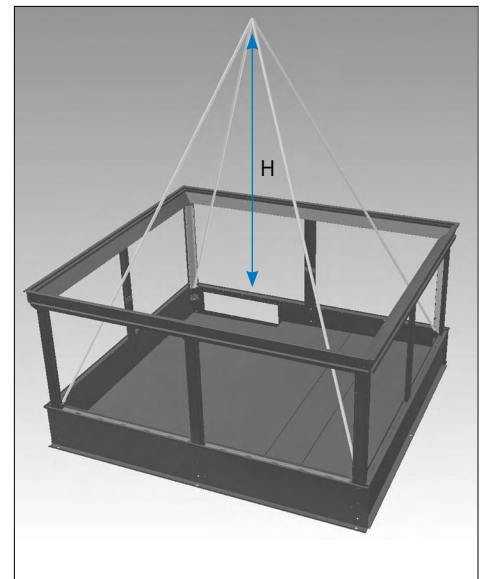

Figure 3. Lower Section Two-Piece Lift

## Rigging

### Section Assembly of Two-Piece Cells

### Section Assembly of Optional Three-Piece Cells

All single cell PT2 Cooling Towers are designed to be lifted in one assembled piece as shown in **Figure 1**. A two-piece lift is shown in **Figures 2** and **3**. All sections, with the exception of the lower section, require the use of a spreader bar. The distance between the spreader bar lifting points must be equivalent to the width between the unit lifting ears. Any motors or accessories shipped in the cold water basin must be removed prior to installation.

## Section Assembly of Two-Piece Cells

1. Remove any motors or accessories shipped in the cold water basin.
2. **Figures 2** and **3** show the proper rigging of the sections for units that ship in two sections. Position the lower section on the steel support and bolt in place. No foam seal tape is required on the InterLok™ System casing joint (see **Figure 4**).
3. Using drift pins in the bolt holes provided, guide the upper section onto the lower section. Match marks must line up.
4. Fasten the hardware between the upper casing and lower section per **Figure 5**.

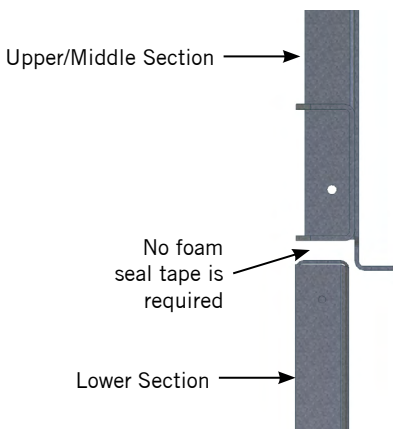

Figure 4. InterLok™ System

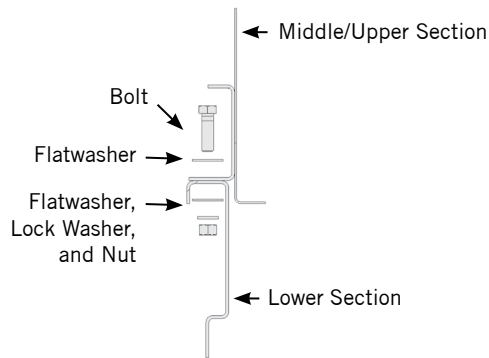

Figure 5. InterLok™ System Hardware Detail



**NOTE:** The IBC Rating is void if the section assembly is not performed as described in this manual.

## Section Assembly of Optional Three-Piece Cells

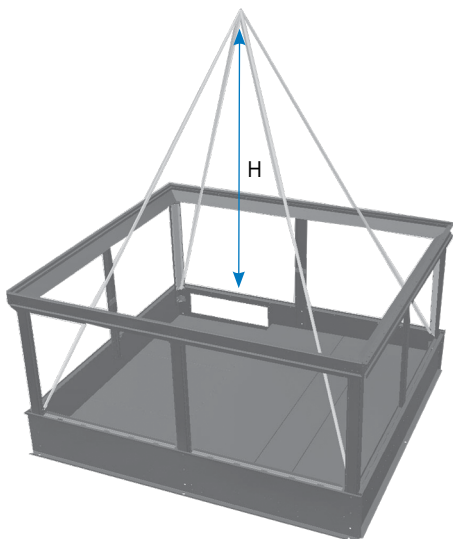

Figure 6a. Lower Section Lift

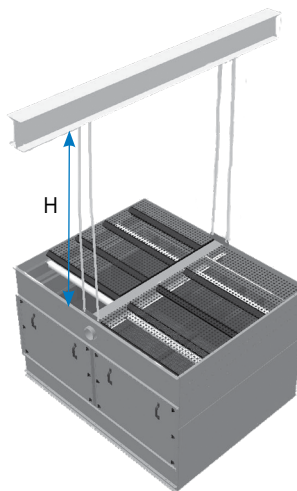

Figure 6b. Middle Section Lift

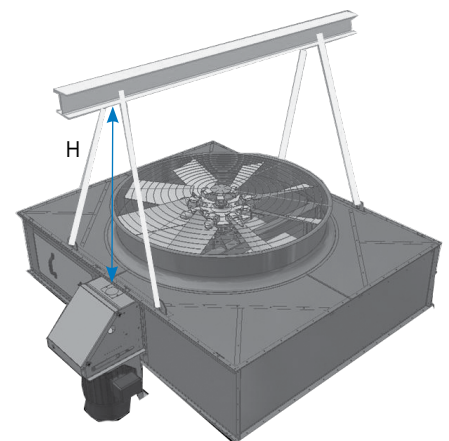

Figure 6c. Fan Section Lift

### Optional Three-Piece Cell Assembly Instructions

1. Remove any motors or accessories shipped in the lower section.
2. **Figures 6a, 6b, and 6c** on **page 5** show the proper rigging for units shipped in three sections.
3. Position the lower section on the unit support and bolt into place. No foam seal tape is required on the middle InterLok™ Casing joint.
4. Using drift pins in the bolt holes provided, guide the middle section onto the lower section. Match marks must line up.
5. Bolt the middle section in place as illustrated in **Figure 5** on **page 5**, using a 3/8" bolt and flat washer.
6. Remove the disposable middle section lifting ears and discard.
7. Next, wipe down the mating surface at the top of the middle section to remove any dirt or moisture that may have accumulated during shipment.
8. Starting at one end, install a layer of 1/8" x 1" foam seal tape (BAC Part # 270567) supplied with the unit around the face of the flange, over the centerline of the holes.
9. Using drift pins in the bolt holes provided, guide the fan section on to the middle section.
10. As illustrated in **Figure 7**, insert 5/16" self-tapping screws in each hole from the upper section into the middle section and tighten.
11. For externally mounted motor models only, attach the motor to the fan section per "Motor Installation Instructions" on **page 9**.

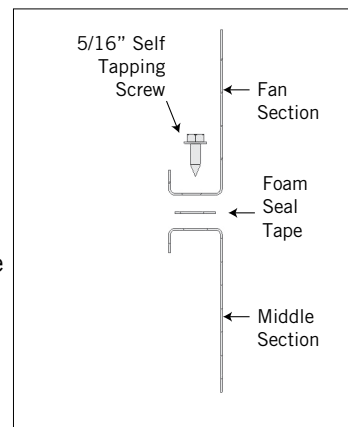

Figure 7. Fan/Middle Section Assembly for Optional Three-Piece Rigging

### Rigging of Containerized Units (Models PT2-0709)

1. Remove the unit from the container.
2. Containerized units ship in two parts within the container, where the fan section is bolted to the lower section and the middle section is separate. Once the unit is removed from the container, remove the bolts holding the fan section to the lower section.
3. Assemble the fan section and the middle section by following steps 7 - 10 in the "Optional Three-Piece Cell Assembly Instructions" section above.
4. Remove any motors or accessories shipped in the lower section.
5. Attach the motor to the fan section per "Motor Installation Instructions" on **page 9**.
6. Assemble the complete unit by following steps 3 - 5 in the "Optional Section Assembly of Three-Piece Cells" section above.

### Multi-Cell Unit Installation

Refer to the submittal drawing unit print for the proper orientation of each cell. All multi-cell units have the cell number and "face" stenciled on the outer basin wall of each section, as well as match marks to show how the cells are to be mated. Multi-cell unit installations may use flume boxes to equalize the water level in the basin of each cell. Follow directions in "Flume Box Installation" on **page 7** for detail on their installation.





### Multi-Cell Unit Assembly

1. First, attach the first cell's lower section to the supports. For units shipped in two sections per cell, follow the instructions in "Section Assembly of Two-Piece Cells" on **page 5**. For units shipped in three sections per cell, follow the instructions in "Section Assembly of Optional Three-Piece Cells" on **page 5**.
2. Each subsequent cell should be assembled just adjacent to its final location, and then properly positioned next to the previous cell. Ensure spacing between the cells at the bottom flange is 1".
3. Some units come furnished with a flume box. If they do, use the flume box assembly procedure outlined below to connect the basins of multi-cell units.

### Flume Box Installation

1. Position Cell #1 on the unit support and bolt in place. Cell #1 will have a factory installed flume box bolted onto Face B.
2. Wipe down the mating surface on the outer, protruding end of the flume box and apply a layer of 1/8" x 1" butyl sealer tape (BAC Part #554000) around the face of the flange over the centerline of the holes. Do not overlap or stretch the butyl sealer tape too thinly at the corners. When it is necessary to splice the butyl sealer tape, be sure to press the two ends together to form a smooth, continuous strip. See **Figure 8**.
3. Apply a second layer of butyl sealer tape over the first layer following the same procedure.
4. Assemble Cell #2 just adjacent to its final location. Wipe down the mating surface adjacent to the flume box opening to remove any dirt or moisture.
5. Position Cell #2 on unit supports. Using drift pins to ensure alignment, draw Cell #2 tight against the flume box, ensuring that the spacing between the cells at the bottom basin flange is 1".
6. As illustrated in **Figure 9**, insert 3/8" x 1 1/4" thread cutting screws in each hole from the flume box into the basin wall and tighten. For basins with TriArmor® Corrosion Protection System and stainless steel basins, bolt strips are provided in lieu of individual thread cutting screws. For TriArmor basins only, a backing plate is provided and must be installed inside of Cell #2, as seen in **Figure 10**. Secure using the provided hardware.

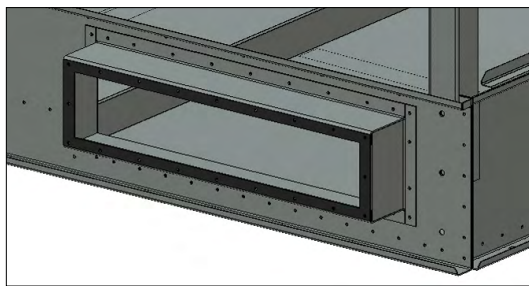
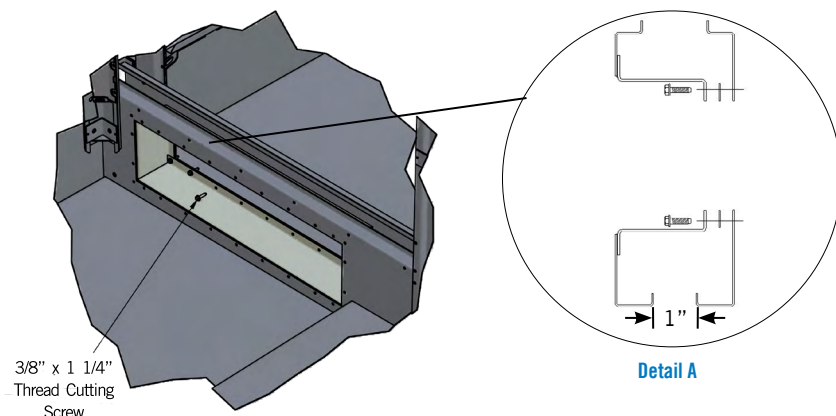

Figure 8. Flume Box Butyl Sealer Tape Application



3/8" x 1 1/4"  
Thread Cutting  
Screw

Detail A

Figure 9. Thread Cutting Screw Pattern for Flume Box

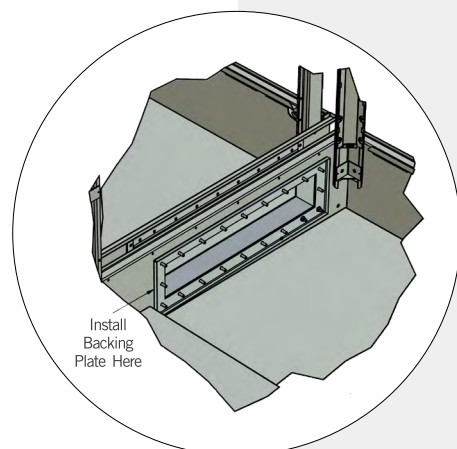

Figure 10. Backing Plate Installation

### Section Assembly of Optional Three-Piece Cells

Optional Three-Piece Cell  
Assembly Instructions

### Rigging of Containerized Units

### Multi-Cell Unit Installation

Multi-Cell Unit Assembly  
Flume Box Installation



**NOTE:** On quad-cell installations, it is suggested that the cells subsequent to the first cell have the upper and lower sections assembled on the support foundation adjacent to the final mounting locations. This will allow space for securing the upper and lower sections of each cell. Slide the subsequent cell(s) to their final position using the lifting devices at the top of the cell(s).



**NOTE:** If the unit is provided with a positive closure plate requiring installation, go to "Positive Closure Plate Installation" on **page 8** prior to installing flat washers and wing nuts.



**NOTE:** If the backing plate is not properly installed, the TriArmor warranty will be void.

### Positive Closure Plate Installation (Figure 11)

The optional positive closure plate and gasket can be furnished on multi-cell units to allow individual cells to be isolated for cleaning and routine maintenance. For PT2 Cooling Towers, the plate ships loose inside the basin. To install the positive closure plate and gasket, follow the steps below.

1. If installed, remove flat washers and wing nuts from the flume box on the interior of Cell #2.
2. Position the neoprene gasket and positive closure plate over the flume box hardware and fasten in place with 3/8" flat washers and wing nuts.

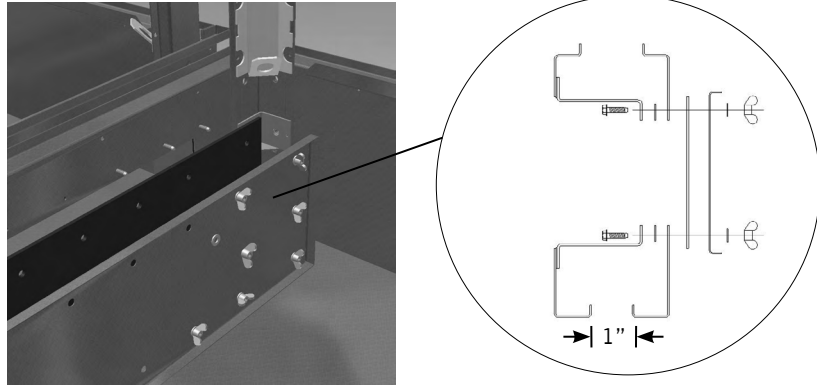

Figure 11. Positive Closure Plate Assembly

Detail A

### Water Baffle Installation (Figures 12a, 12b, and 12c)

For multi-cell PT2 Cooling Towers (excluding Factory Mutual (FM) units), water baffles join the interior basin sections to prevent leaks between modules. **Install the anchor bolts in all cells before installing the water baffles.** To install the water baffles, follow the steps below.

1. Slide the lower water baffle into place. The baffle is in its final position when the end plates are in contact with the end wall flanges.
2. Orient the side baffles with the flanges facing out. Install the left and right side water baffles by first aligning top notches and then sliding the bottom of the baffle into place.
3. Secure the base of sides baffles with two #14 (1/4") self-tapping screws in each hole provided.

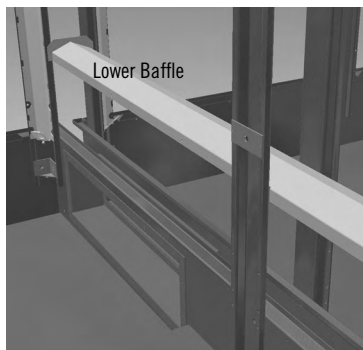

Figure 12a. Step 1

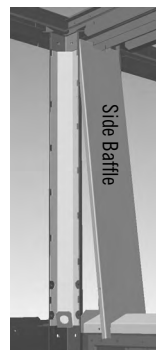

Figure 12b. Step 2

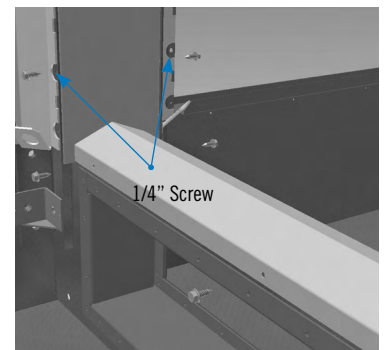

Figure 12c. Step 3

### Multi-Cell Factory Mutual (FM) Partition Panels (Optional)

Partition panels are provided for PT2 Cooling Towers with FM approval.

1. Set the base of the panel support into the upper basin flange while positioning the support bracket as shown in **Figure 13, Detail A**. Slide the support bracket up behind the corner gussets on the columns.
2. Secure the panel support to the support bracket with 5/16" self-tapping screws.
3. Secure the partition to the panel support using 5/16" self-tapping screws. The panel should be flush with the top of the panel support.

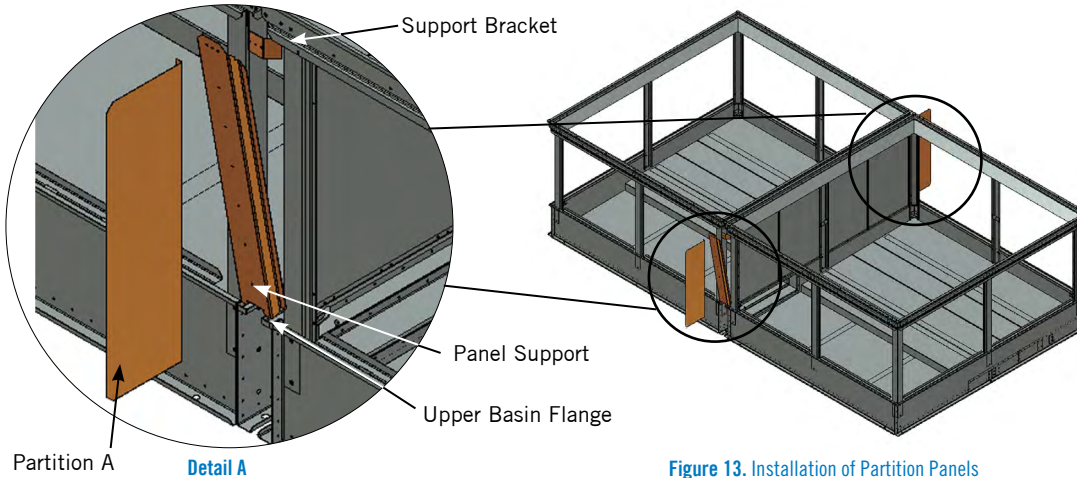

Figure 13. Installation of Partition Panels

### Motor Installation for PT2-0709, PT2-0809, PT2-0812, and PT2-0814 (Figure 14)

1. Attach the lifting strap to the motor base eyelets and remove the motor and the motor base assembly from the basin. The motor assembly must remain vertical to maintain proper alignment during installation.
2. Lift the external motor assembly into position next to the access door.
3. Attach the assembly to the unit using the six 1/2" studs, flatwashers, lock washers, and nuts.
4. Install the powerband, check sheave alignment, and tension the power band. For correct sheave alignment and tensioning specifications and procedures, refer to the *PT2 Operation & Maintenance Manual*.

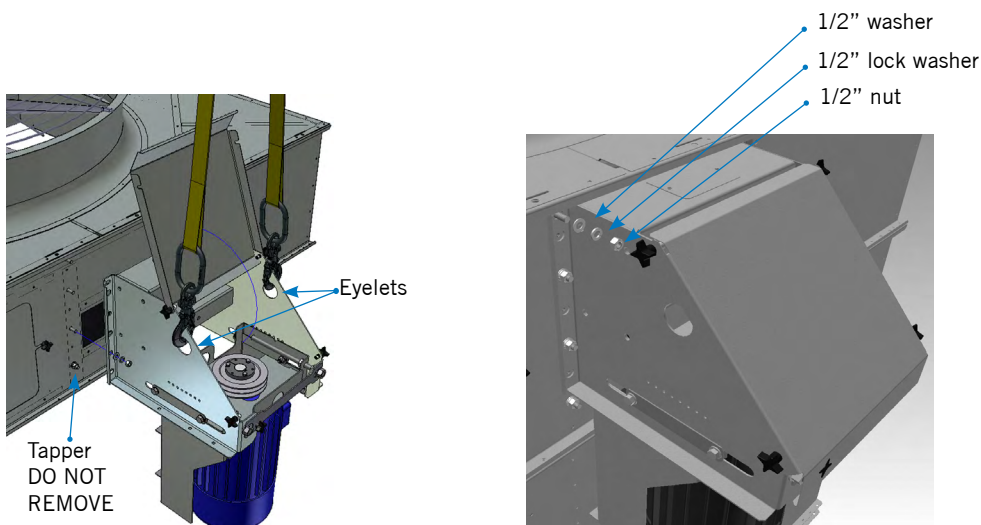

Figure 14a. External Motor Mount Assembly Lift

Figure 14b. External Motor Mount Assembly Pattern

### Multi-Cell Unit Installation

Positive Closure Plate Installation  
Water Baffle Installation  
Multi-Cell FM Partition Panels (Optional)

### Motor Installation for PT2-0709, PT2-0809, PT2-0812, and PT2-0814



**WARNING:** Ensure that the fan guard is properly installed prior to commencing operation.



**NOTE:** All other PT2 models have the fan motor mounted and belt tensioned at the factory.



**NOTICE:** Do not remove tappers from the fan section during the installation of the external motor. Removing tappers will cause the interior mechanical system to fall.

**DANGER:** Fan guard must be securely in place before the cooling tower is placed in operation. Never step or walk on the fan guard. Failure to follow these instructions may result in serious injury or death.



## Fan Guard Installation

As standard, the fan guard ships installed on all PT2 units except for the PT2-1218, which ships unmounted. However, due to height limitations on specific truck shipments, the fan guard for other PT2 models may ship unmounted.

### One-Piece Fan Guard

Mount the fan guard to the unit as illustrated in **Figure 15, Detail A**.

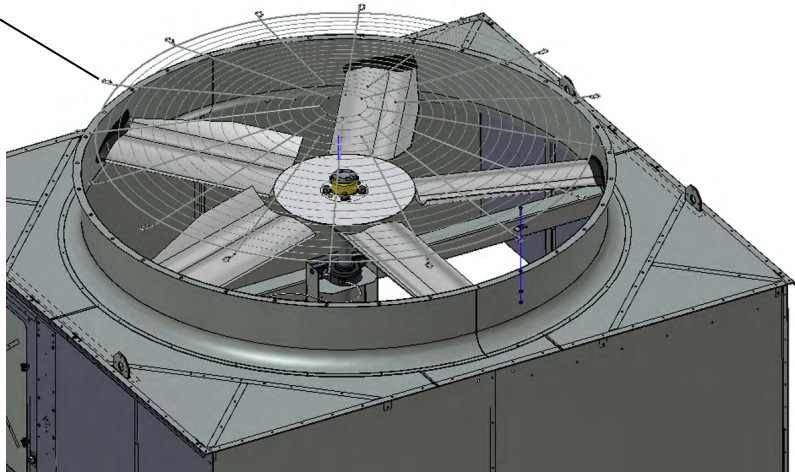
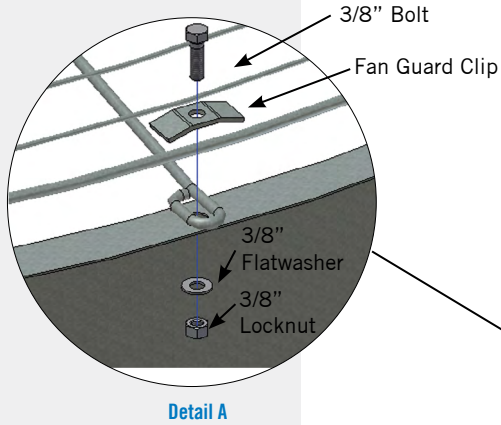

Figure 15. One-Piece Fan Guard Assembly



Fan Guard Installation

- One-Piece Fan Guard
- Two-Piece Fan Guard

**Two-Piece Fan Guard**

1. Using six U-bolt assemblies, fasten the two halves of the fan guard together as illustrated in **Figure 16, Detail B**. Locate the U-bolt assemblies along the seam between the two guard halves per the X and Y dimension provided in **Table 2**, which are based on the diameter of the supplied fan.
2. Gradually tighten both nuts of the U-bolt assembly, alternating from one to the other, until 20-25 ft-lb of torque is achieved.
3. Mount the fan guard to the unit as illustrated in **Figure 16, Detail A** for the ends of the seam where the two guard halves join together, and Detail C for all other locations around the fan guard perimeter.

Fan Diameter	X	Y
9'	10"	17"
10'	10"	20"
11'	10"	23"

Table 2. U-Bolt Location Dimensions for Two-Piece Fan Guard Fastening

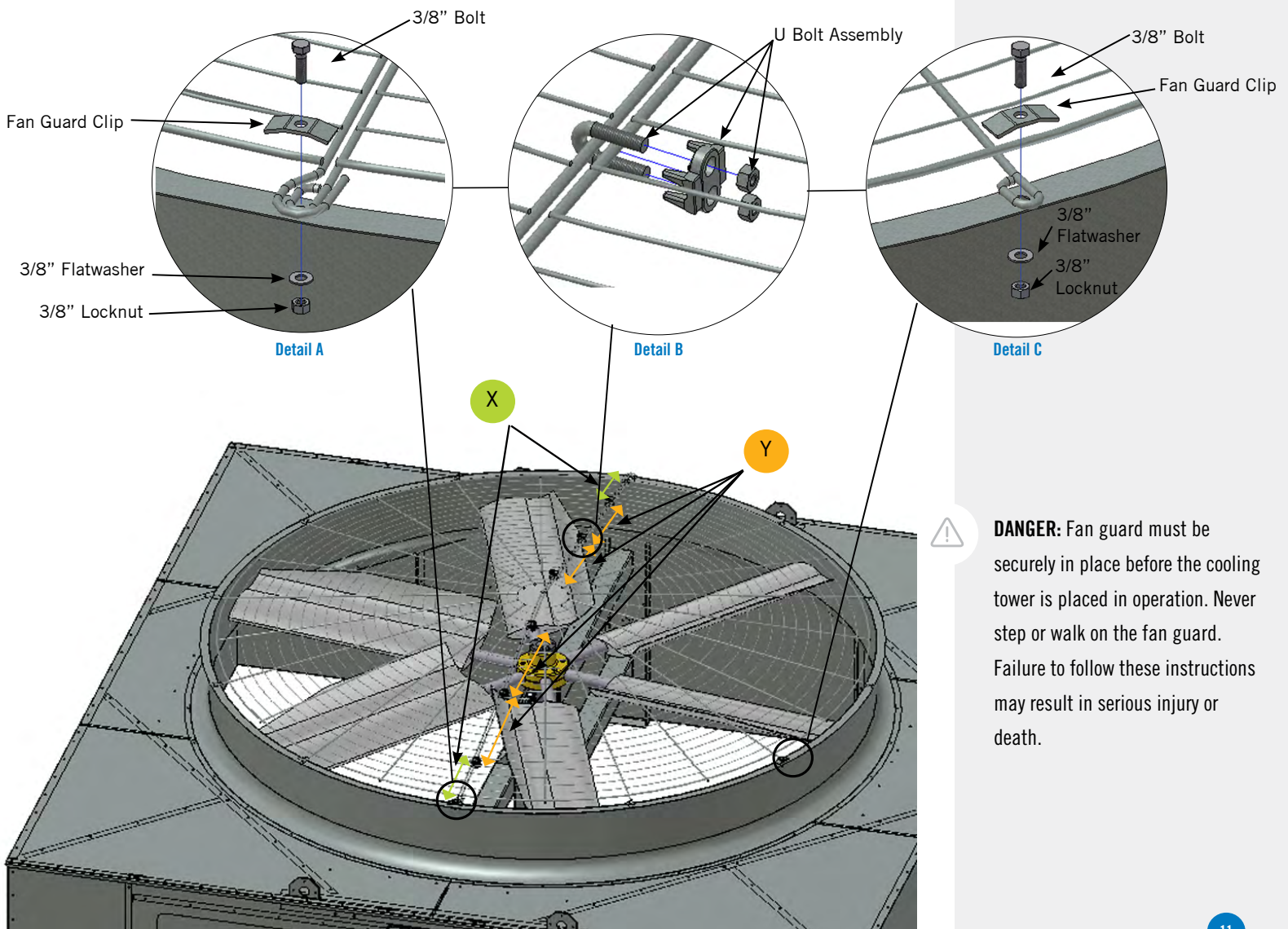

**DANGER:** Fan guard must be securely in place before the cooling tower is placed in operation. Never step or walk on the fan guard. Failure to follow these instructions may result in serious injury or death.

Figure 16. Two-Piece Fan Guard Assembly

# 3 Optional Accessory Installation

## Side Outlet Depressed Sump Box (Optional)

The optional side outlet depressed sump box allows a cooling tower water outlet connection to be piped from underneath the unit in four possible directions, 90° apart. The piping connection is a bolt circle designed to fit an ASME Class 150 flat flange with a full-face gasket. To install the side outlet depressed sump box, follow the steps below.

1. Wipe the edges around the opening inside the cold water basin to remove any dirt or moisture that may have accumulated during shipment.
2. Apply a layer of 1/8" x 1" butyl sealer tape around the opening in the basin over the centerline of the holes. Do not stretch the sealer tape too thinly or overlap at the corners. When it is necessary to splice the sealer tape, be sure to press the two ends together to form a smooth continuous strip. Apply a second layer of sealer tape over the first layer following the same procedure. Refer to **Figure 17**. The sealer tape needs to be positioned between the sump box and the inside basin bottom.
3. Insert the sump box assembly into the opening in the cold water basin and attach it to the basin with 3/8" x 1" bolt and nuts, flat washers, and lock washers as shown in **Figure 17, Detail A**.
4. Place the suction strainer over the opening as shown in **Figure 17**.

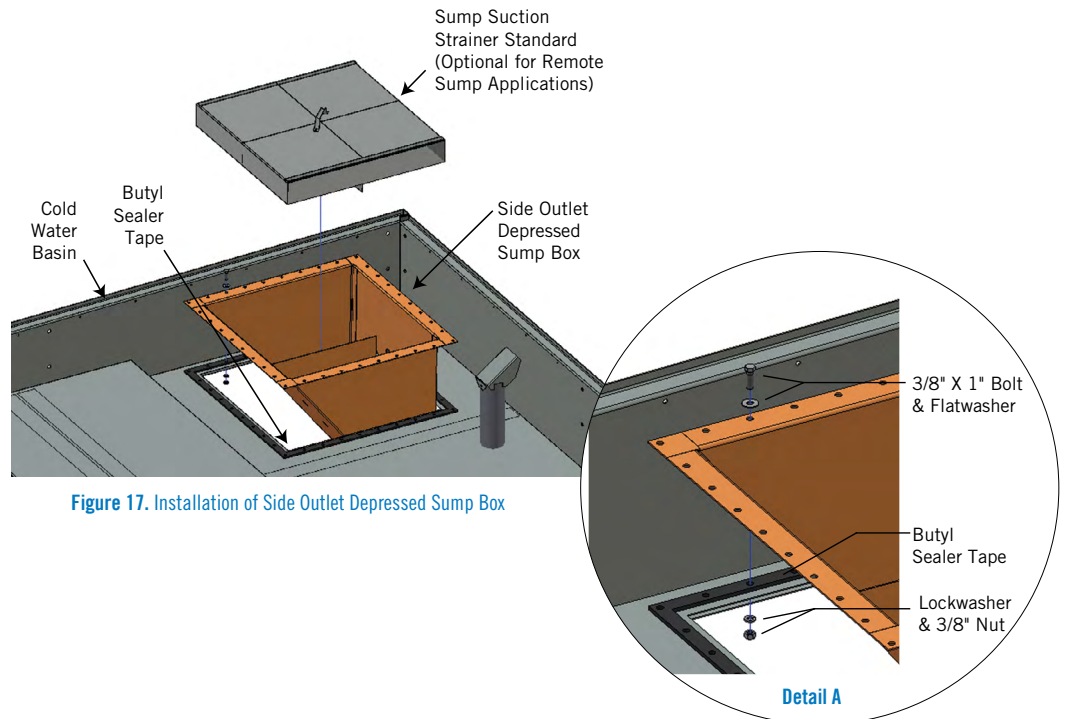

Figure 17. Installation of Side Outlet Depressed Sump Box



## Bottom Water Outlet (Optional)

1. The bottom connection seal, **Figure 18**, is typical for all bottom outlets, equalizers, and bypasses. Flange mounting hardware and gasket to be supplied by others.
2. Bottom connection seal kit(s) ship in plastic tubs.

Side Outlet Depressed Sump  
Box

Bottom Water Outlet

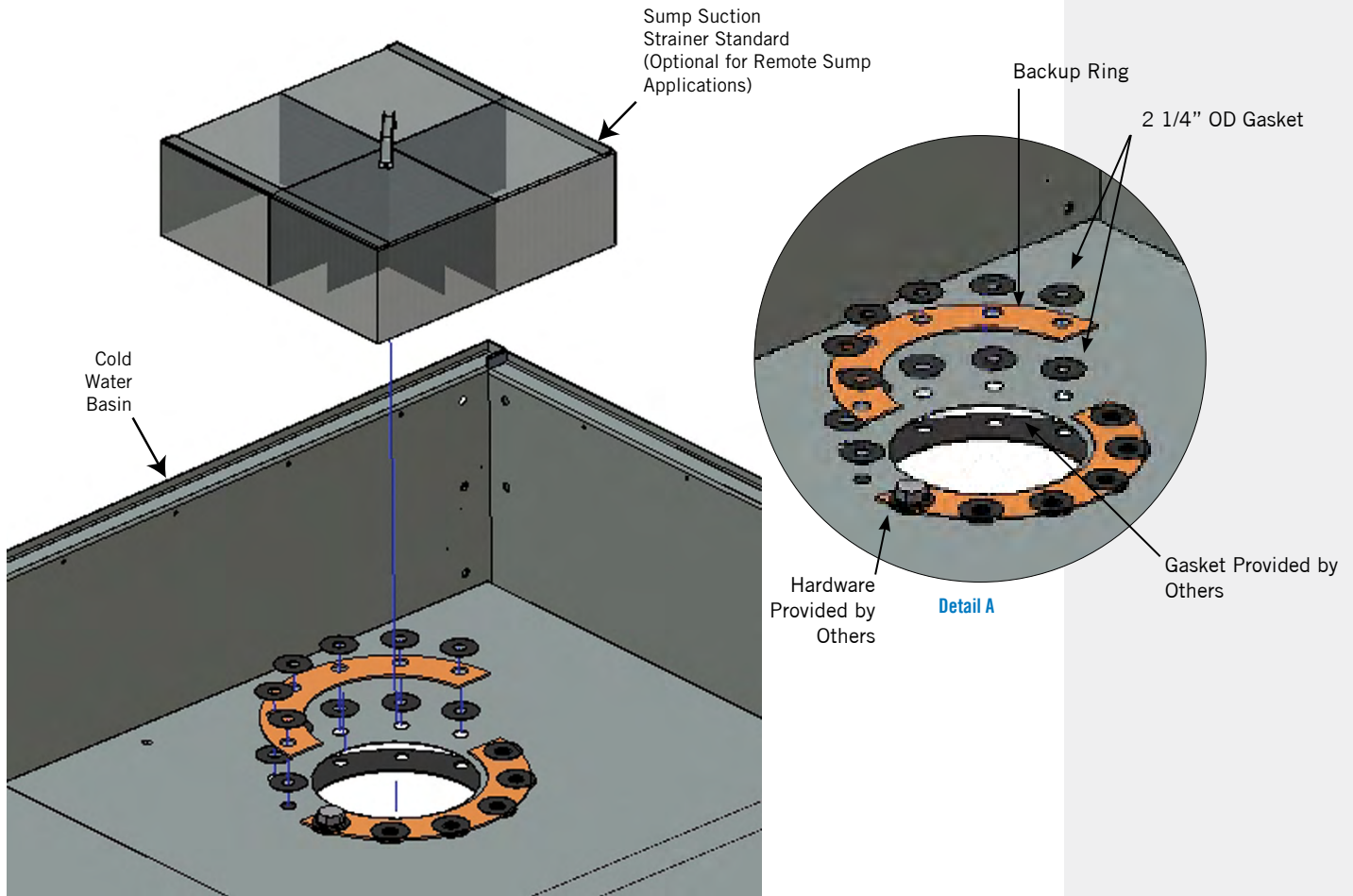

Figure 18. Bottom Water Outlet

## Fan Cowl Extensions (Optional)

Each Fan cowl extension is 10 1/2" tall and up to four fan cowl extensions may be installed.

1. Fasten the fan cowl extensions through the large diameter pre-punched holes using the provided hardware as shown in **Figure 19, Detail A**.
2. Follow the "Fan Guard Installation" instructions on **page 10** to install the fan guard.

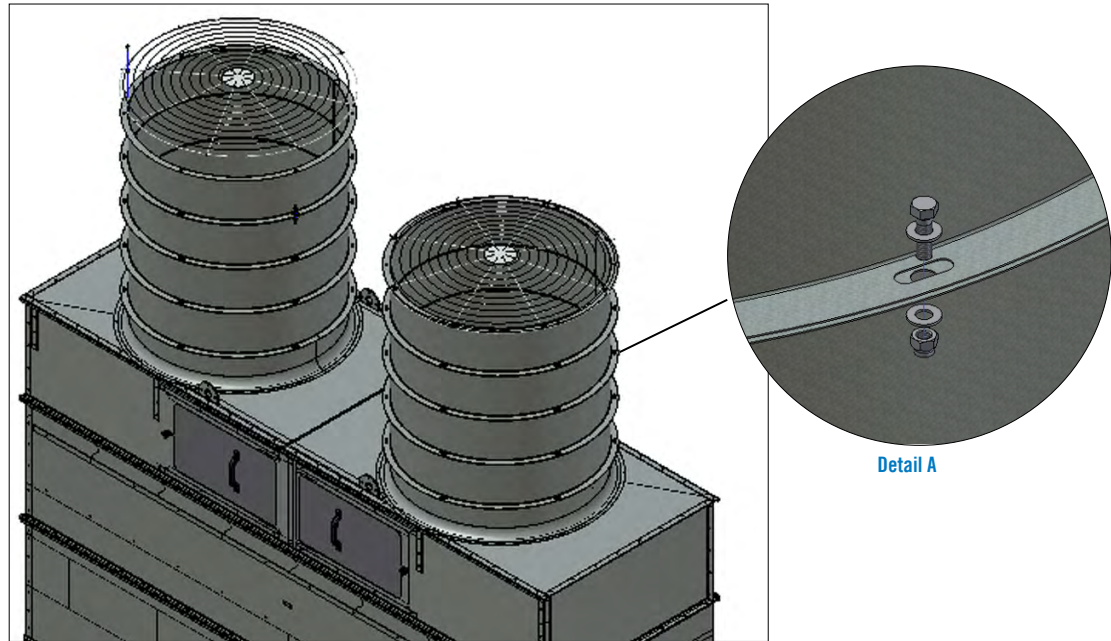

Figure 19. Fan Cowl Extensions

### NOTES:

1. Fan cowl extensions can be added at the time of order or as an aftermarket item.
2. Discharge sound attenuation can be added at the time of order or as an aftermarket item.

## Discharge Sound Attenuation (Optional on PT2-0412 Only)

1. Verify the mounting guides (8 total) are factory installed.
2. Lower the attenuator assembly into position as shown in **Figure 20**.
3. Utilizing the supplied hardware, secure the attenuator assembly as shown in **Figure 20, Detail A**, to the mounting guides.

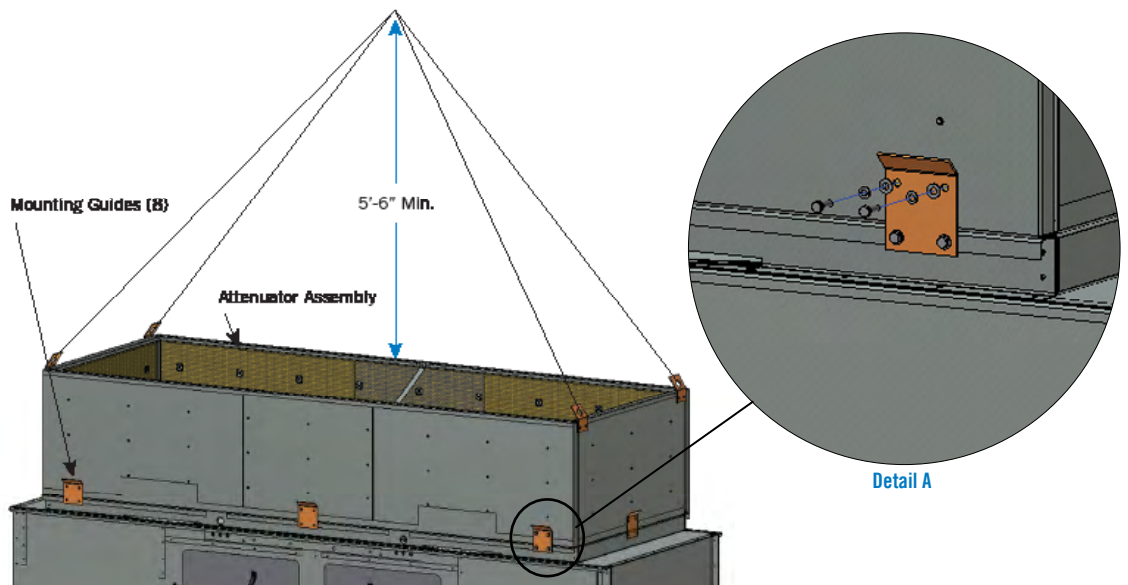

Figure 20. Discharge Sound Attenuation



## Motor Removal Davit (Optional)

### PT2-0709, PT2-0809, PT2-0812, and PT2-0814 (see Figure 21a)

1. Remove the cover plate from the upper support channel.
2. Rotate the davit assembly to align the bolt head on the davit with the keyway in the upper support channel and lower into position. The davit must pass through the upper and lower support channel and rest on support base.

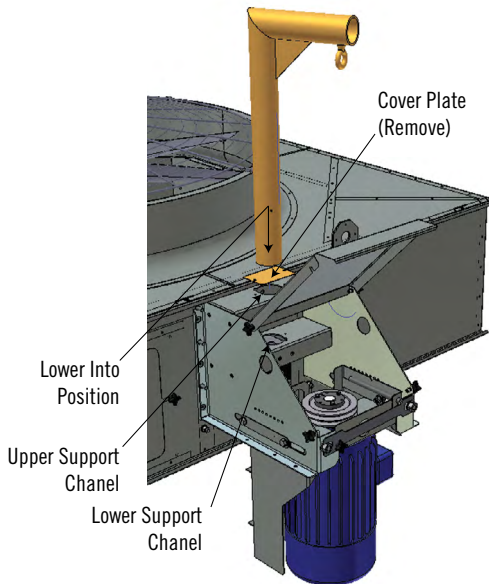

Figure 21a. Motor Removal Davit Installation for PT2-0709, PT2-0809, PT2-0812, and PT2-0814

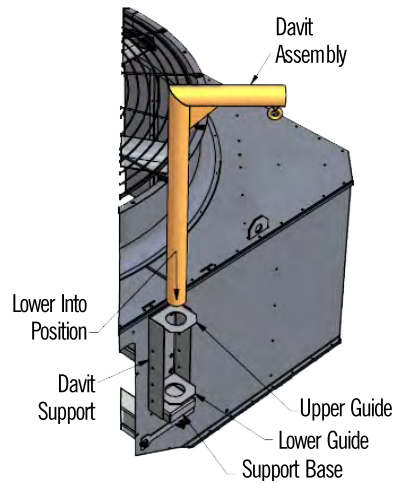

Figure 21b. Motor Removal Davit Installation for PT2-1009, PT2-1012, PT2-1212, PT2-1214, and PT2-1218

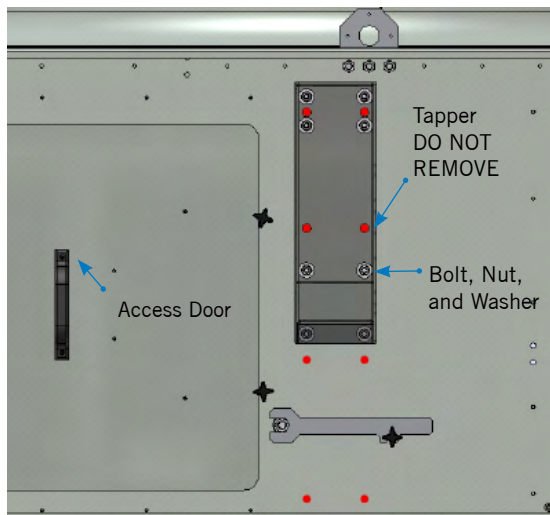

Figure 21c. Davit Support Detail

### PT2-1009, PT2-1012, PT2-1212, PT2-1214, and PT2-1218 (see Figure 21b)

1. Verify the davit support is factory installed next to the access door. If not installed, remove the bolts next to the access door (refer to **Figure 21c**). **DO NOT REMOVE TAPPERS**. Secure the davit support by re-installing the bolts.
2. Rotate the davit assembly to align the bolt head on the davit with the keyway in the upper support channel and lower into position. The davit must pass through the upper and lower support channels and rest on the support base.



## Optional Accessory Installation

### Fan Cowl Extensions

### Discharge Sound Attenuation

### Motor Removal Davit

PT2-0709, PT2-0809, PT2-0812, and PT2-0814

PT2-1009, PT2-1012, PT2-1212, and PT2-1218



**NOTE:** The maximum weight load capacity of the motor removal davit is 630 lbs for PT2-0709, PT2-0809, PT2-0812, and PT2-0814 units.



**NOTE:** The maximum weight load capacity of the motor removal davit is 830 lbs for PT2-1009, PT2-1012, PT2-1212, PT2-1214, and PT2-1218 units.



**NOTICE:** Do not remove tappers during installation of motor removal davit support. Removing tappers will cause the interior mechanical system to fall.

## NOTES:

1. Platforms, ladders, and safety cages can be added at the time of order or as an aftermarket item.
2. Safety gates are provided for all handrail openings. All components are designed to meet OSHA requirements.



## Inclined Access Ladder (Optional)

Refer to Figures 22 to 24 for your particular unit.

1. Install the upper bracket as shown in **Figures 22 to 24, Detail A**. Depending on the unit, this bracket might be factory installed.
2. Install the lower bracket(s) in the two outermost holes in adaptor channel as shown in **Figures 22 to 24, Detail B**.
3. For PT2-1009, PT2-1012, PT2-1212, and PT2-1218 units, install the center adapter and bracket as shown in **Figure 24, Detail D**. To install, fasten the center bracket to the adapter, but do not tighten the fasteners. The bracket flanges should face toward the unit end wall while the adapter is oriented with the holes positioned on top. Capture down break on channel between the bracket and adapter.
4. Do not tighten the fasteners until the ladder is in position.
5. Position the ladder on the upper bracket and fasten in place.
6. Secure the ladder to the lower bracket(s) and the center bracket (for PT2-1012, PT2-1212, and PT2-1218 units) utilizing the ladder clamps provided.
7. Loosely fasten the diagonal braces of the lower support assembly into position with the ladder clamps, as shown in **Figures 22 to 24, Detail B and Detail C**.
8. Adjust the ladder clamps on the diagonal brace vertically to ensure that ladder(s) are perpendicular to unit and tighten outer ladder clamps.
9. Check and tighten all remaining ladder fasteners before using the ladder(s).

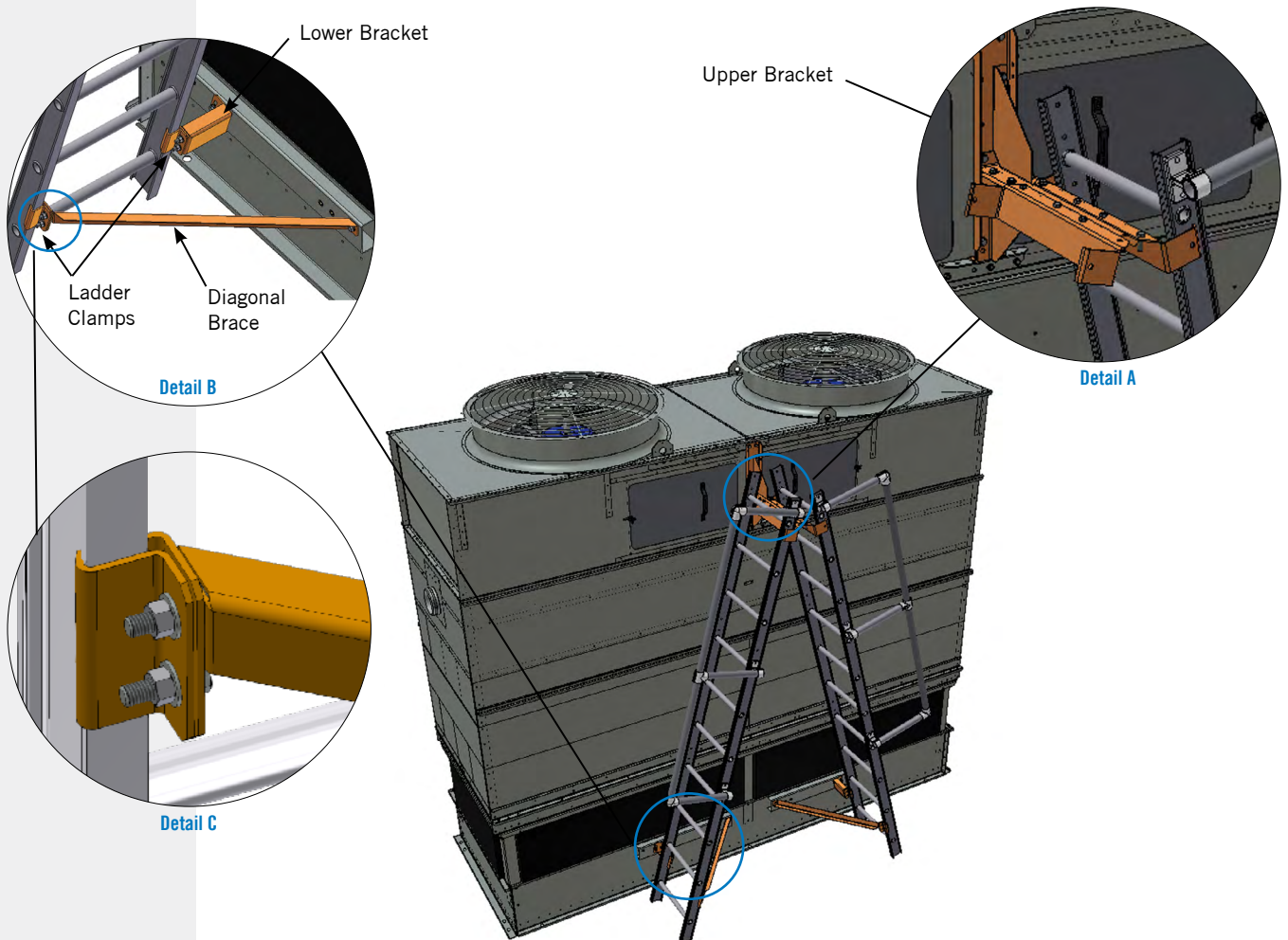

Figure 22. Inclined Access Ladders for PT2-0412

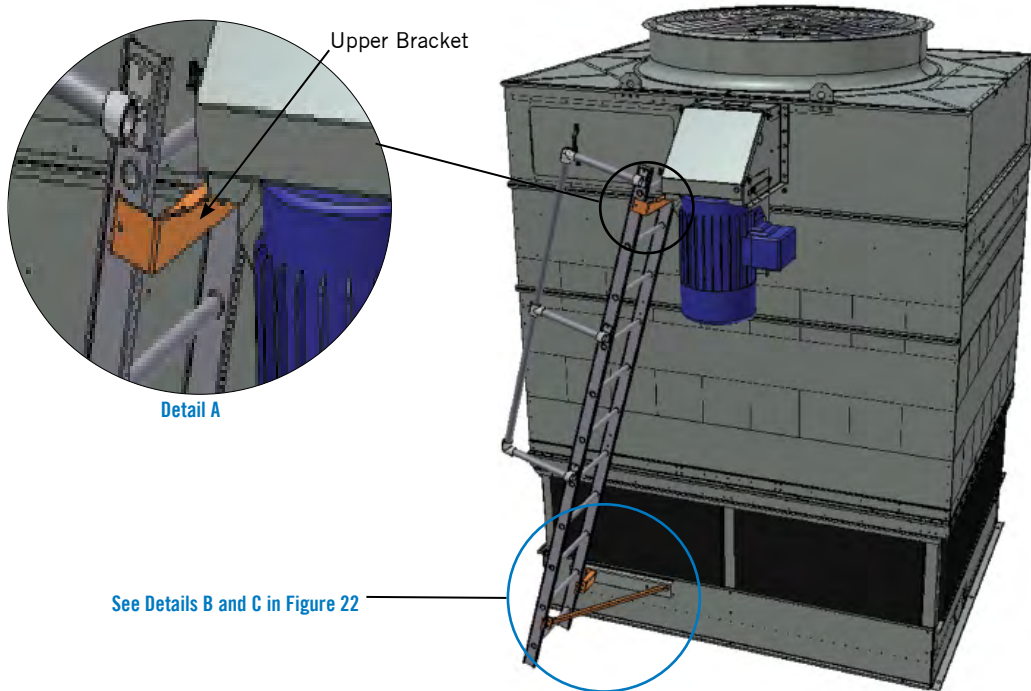

Figure 23. Inclined Access Ladder for PT2-0709, PT2-0809, PT2-0812, and PT2-0814

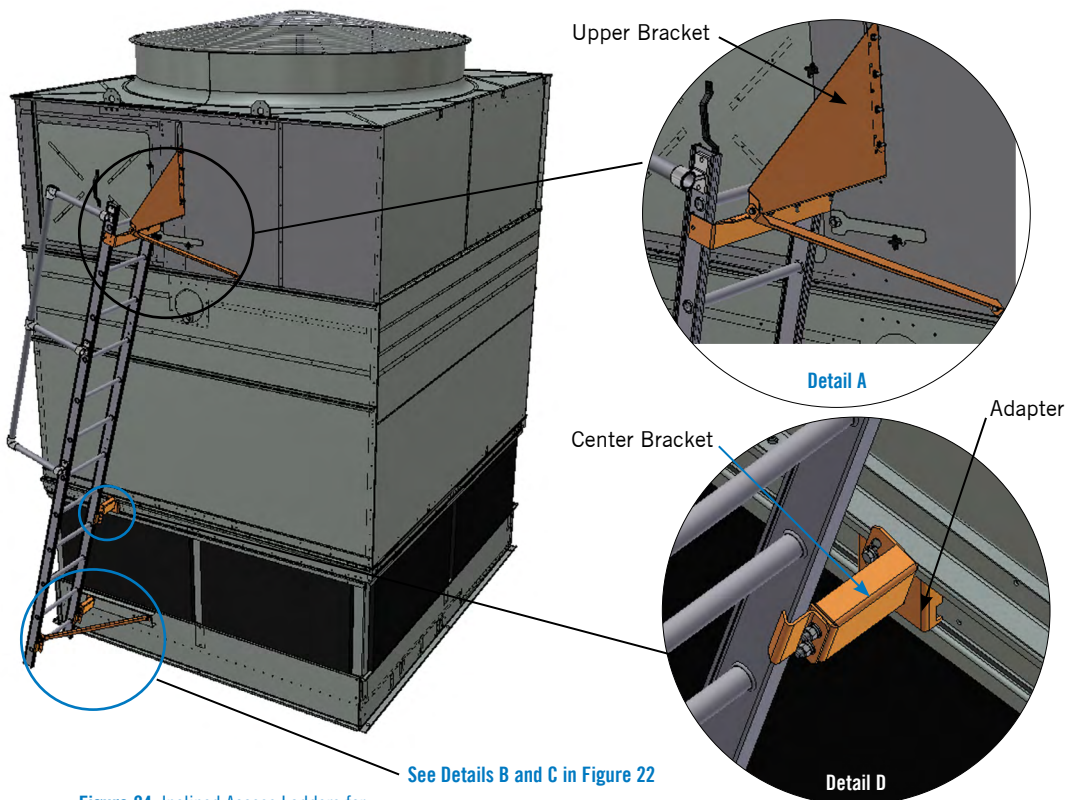

Figure 24. Inclined Access Ladders for PT2-1009, PT2-1012, PT2-1212, PT2-1214, and PT2-1218



## Mechanical Access Platform (Optional; for PT2-0814 and PT2-1214, see page 25)

Refer to **Figures 25 to 33** on **pages 18 to 24** for your unit platform assembly.

1. Lift the hang-on module(s) into place by placing the hangers into the notches at the top of the unit. Secure the module(s) to the unit using 3/8" bolts provided. See **Detail A (Figures 25 to 33)**.
2. Slide the platform clamps behind the panel flanges and secure to platform. See **Details B and C (Figures 25 to 33)**.
3. Secure the adjustable extension to the flange at the top of the lower section as shown in **Detail D (Figures 25 to 33)**.
4. If applicable, lift the bridge section(s) between the mounted hang-on modules and lower into position so that it rests on support channels. Fasten the bridge section(s) to the support channels at 4 places using 3/8" x 1 1/4" hardware supplied. See **Detail E (Figures 26, 27, 29, 30, 31, 32, and 33)**.

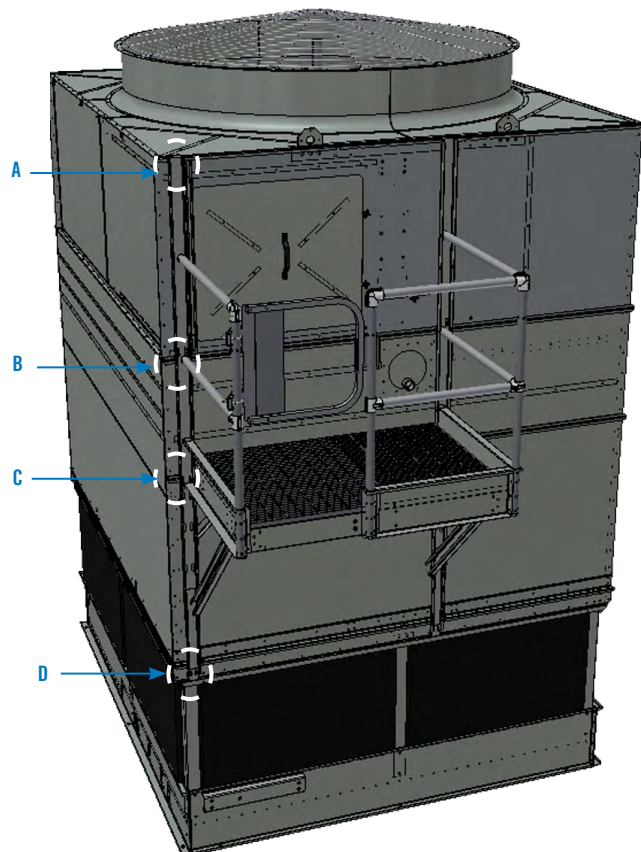
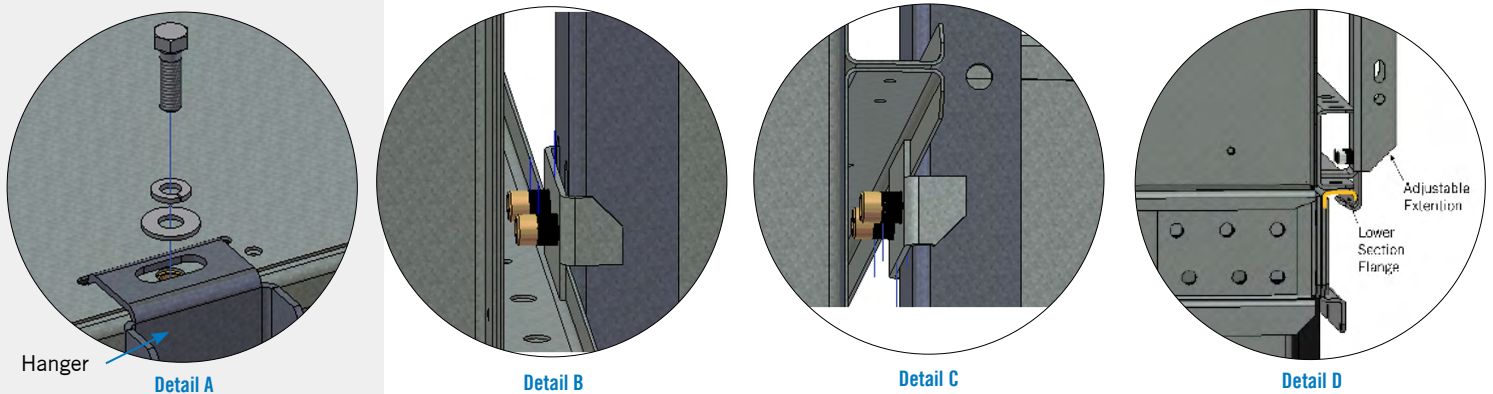

Figure 25. Mechanical Access Platform for One Cell Units (Except for PT2-0812, PT2-1214, and PT2-1218)



## Optional Accessory Installation

Mechanical Access Platform  
(Optional, PT2-0814 and PT2-1214)

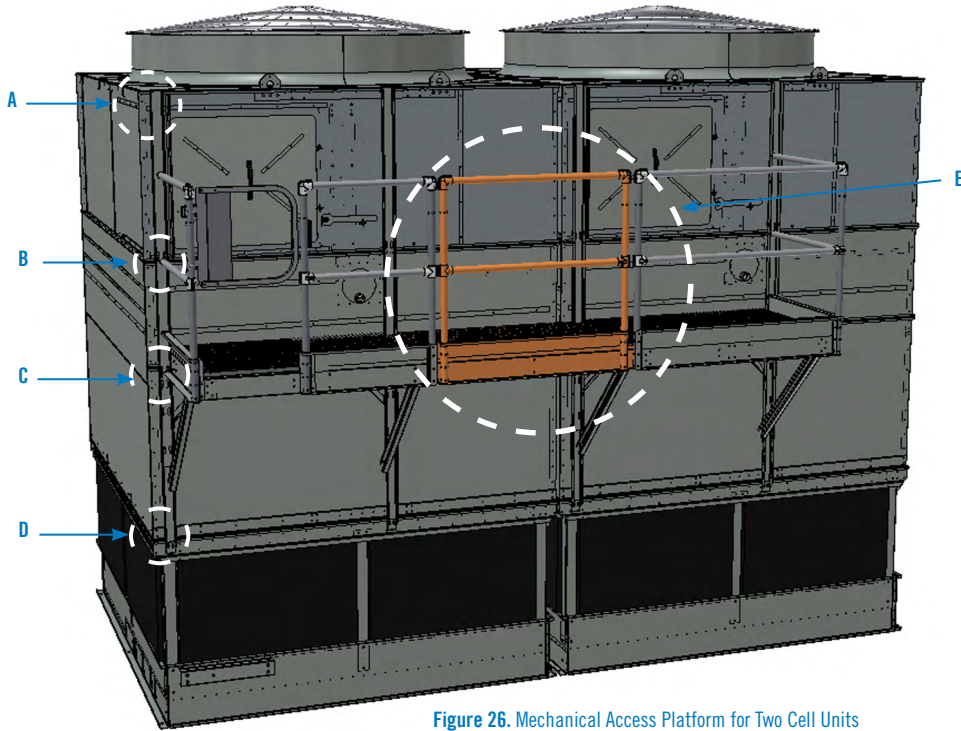

Figure 26. Mechanical Access Platform for Two Cell Units  
(Except PT2-0814, PT2-1214, and PT2-1218)

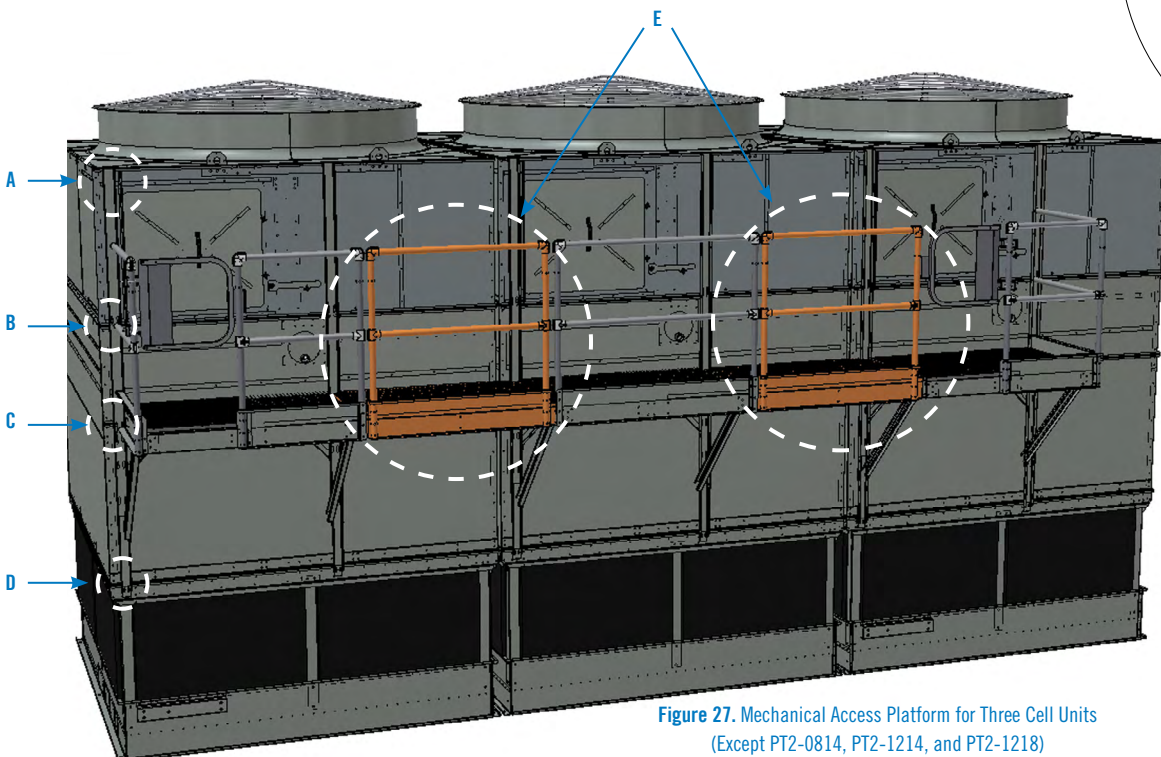
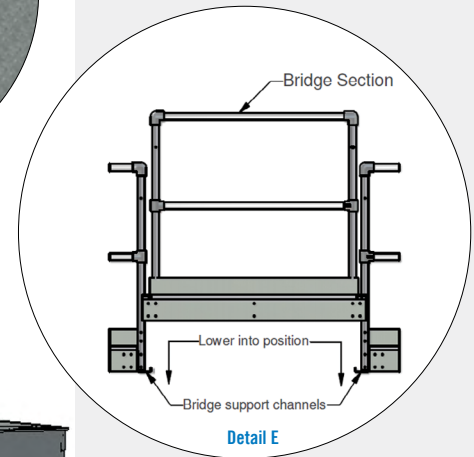
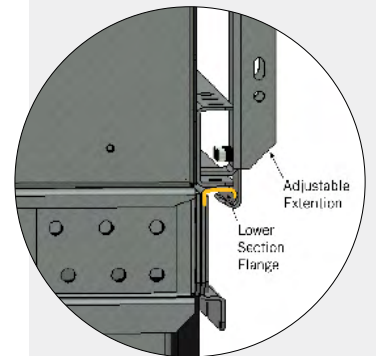
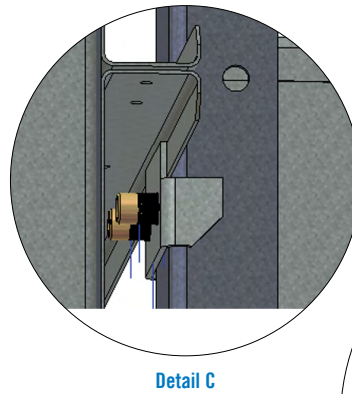
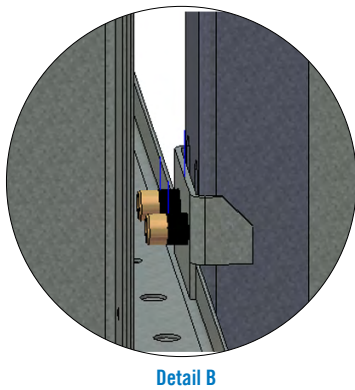
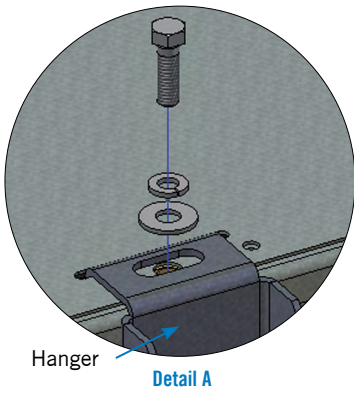

Figure 27. Mechanical Access Platform for Three Cell Units  
(Except PT2-0814, PT2-1214, and PT2-1218)



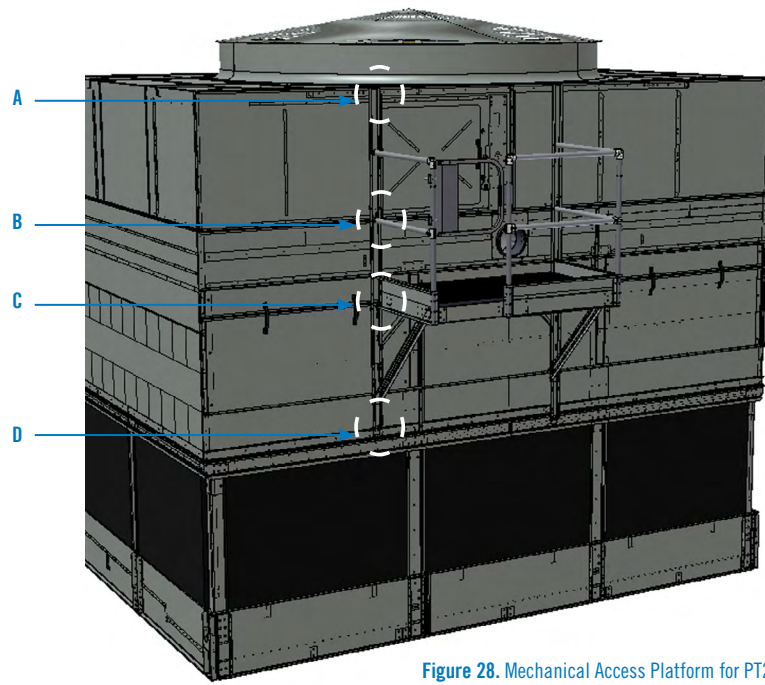
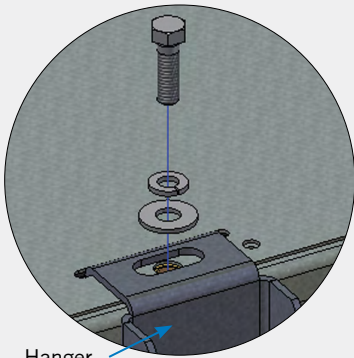
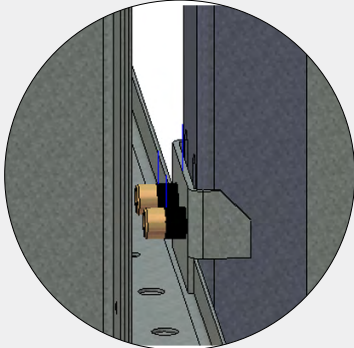

Figure 28. Mechanical Access Platform for PT2-1218 with One Fan



Detail A



Detail B

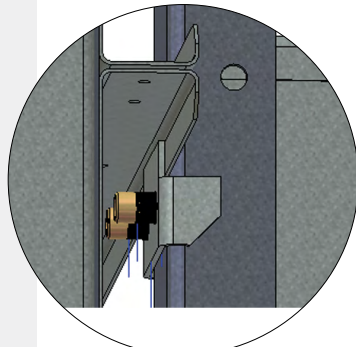

Detail C

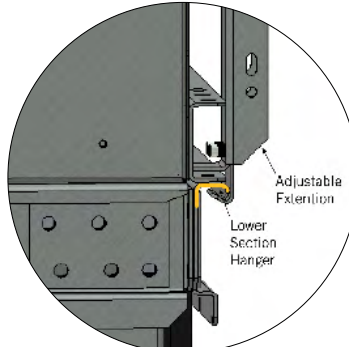

Detail D

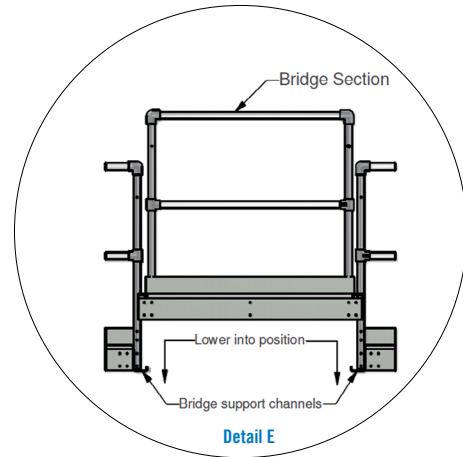

Detail E

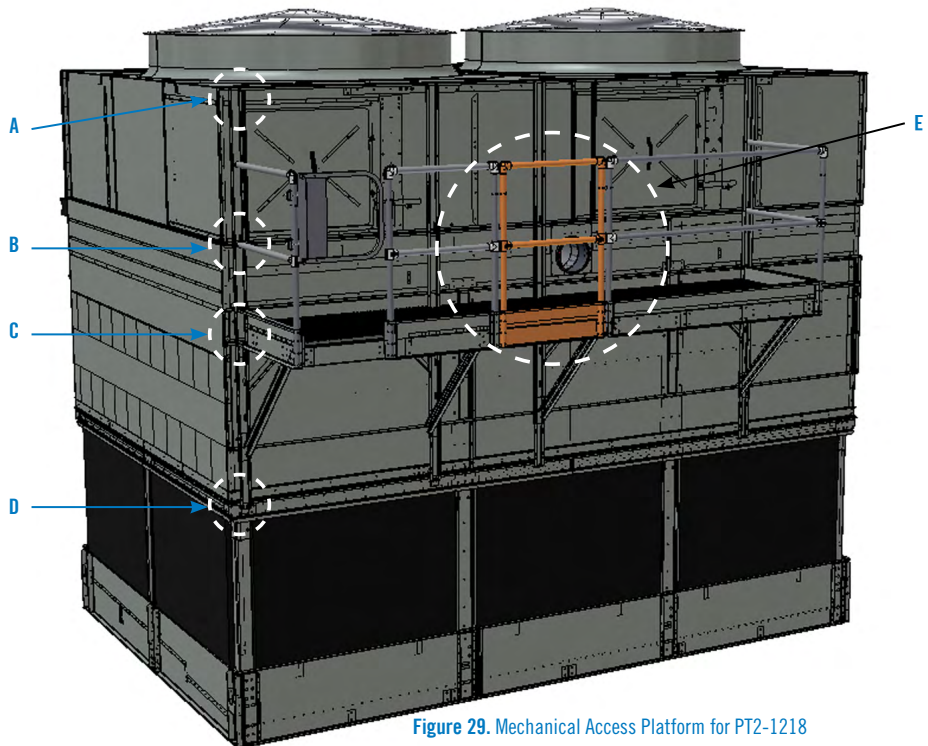
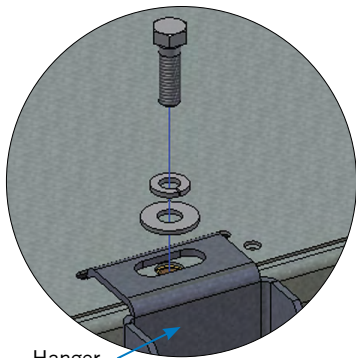

Figure 29. Mechanical Access Platform for PT2-1218 with Two Fans



## Optional Accessory Installation

Mechanical Access Platform  
(Optional, PT2-0814 and  
PT2-1214)



Hanger  
Detail A

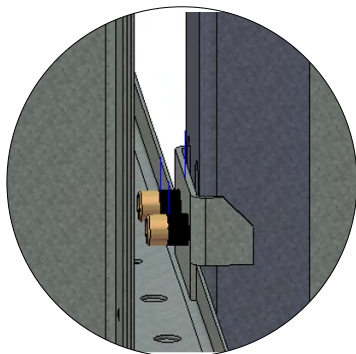

Detail B

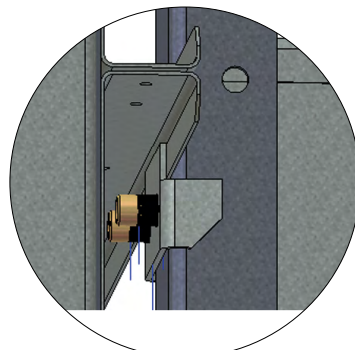

Detail C

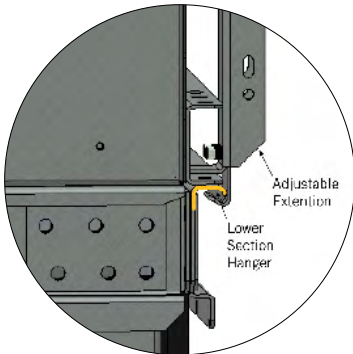

Detail D

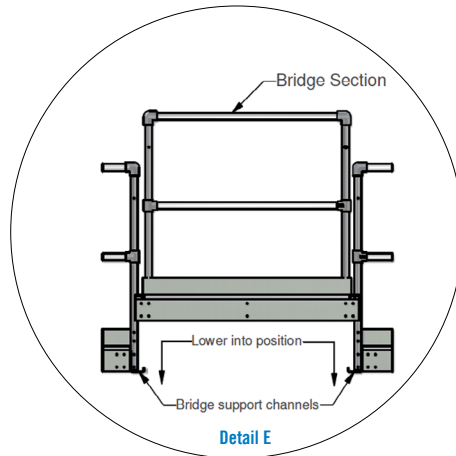

Detail E

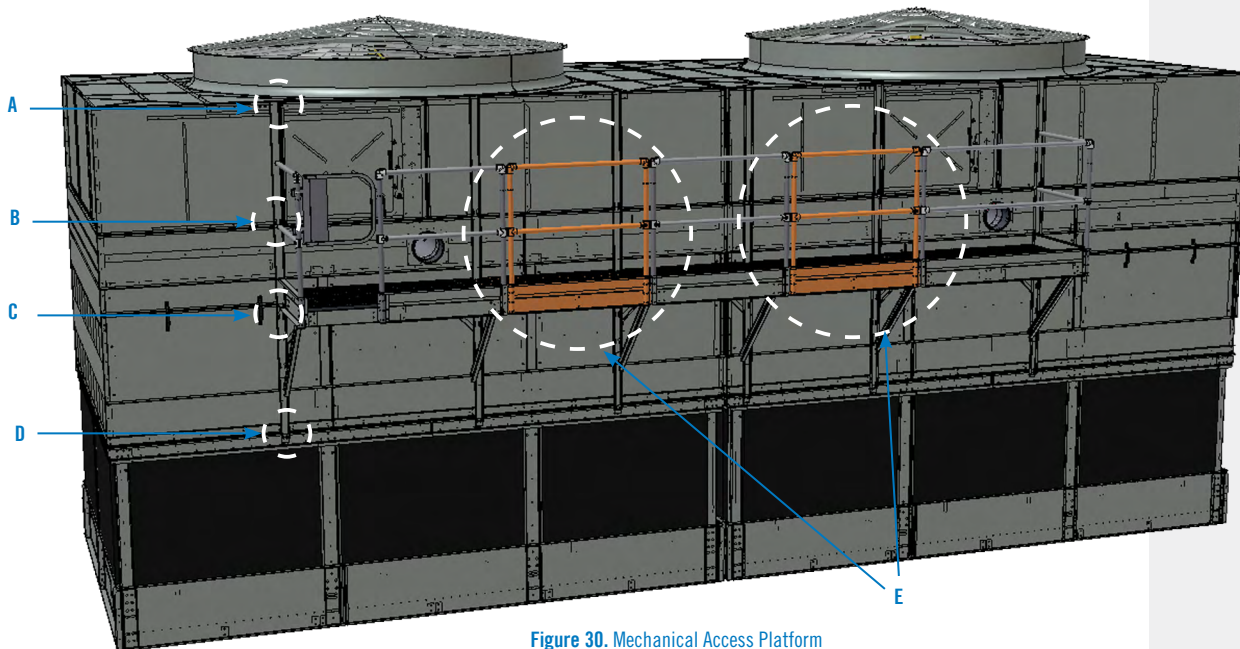

Figure 30. Mechanical Access Platform  
for PT2-1218 with One Fan and Two Cells



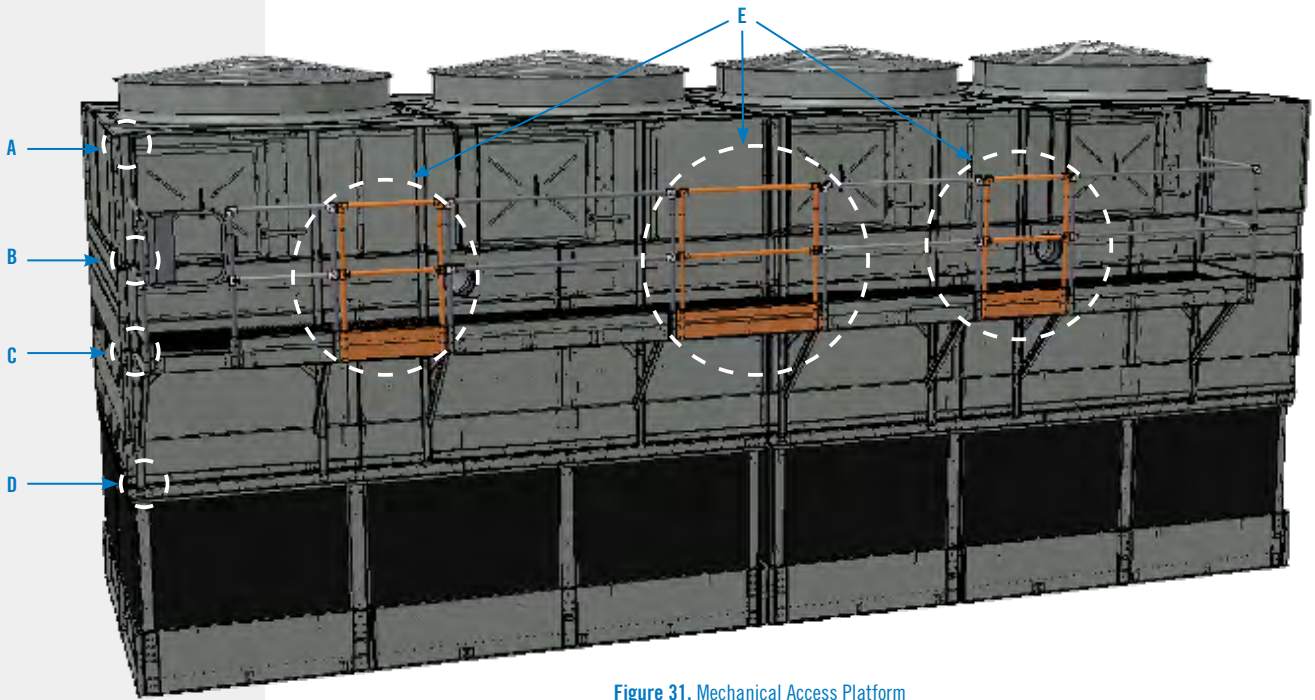
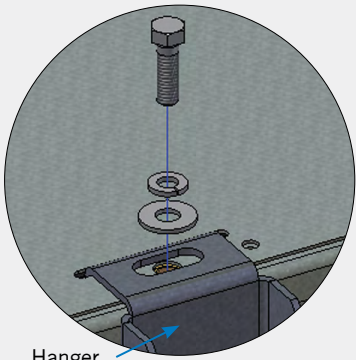
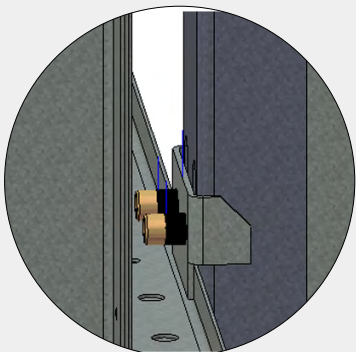

Figure 31. Mechanical Access Platform for PT2-1218 with Two Fans and Two Cells



Detail A



Detail B

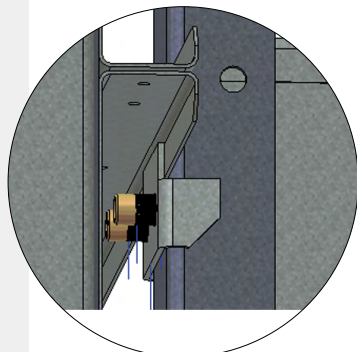

Detail C

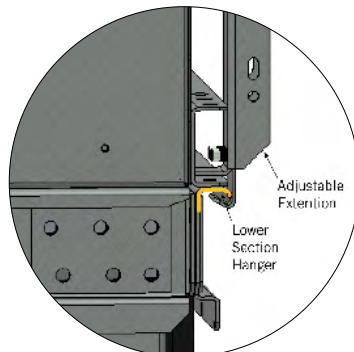

Detail D

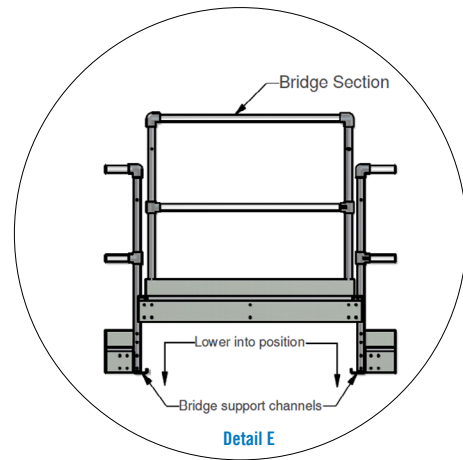

Detail E





## Optional Accessory Installation

### Mechanical Access Platform (Optional, PT2-0814 and PT2-1214)

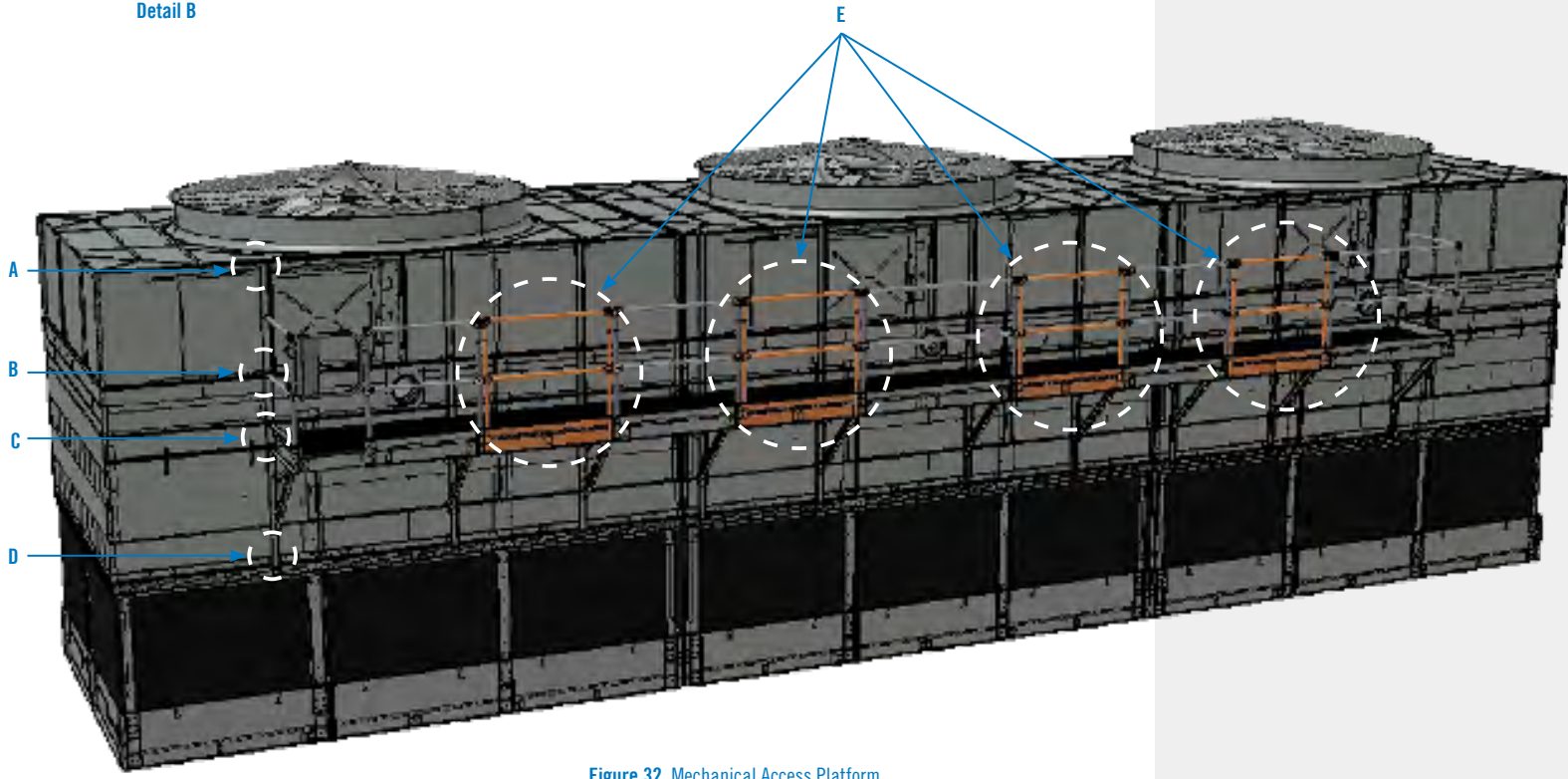
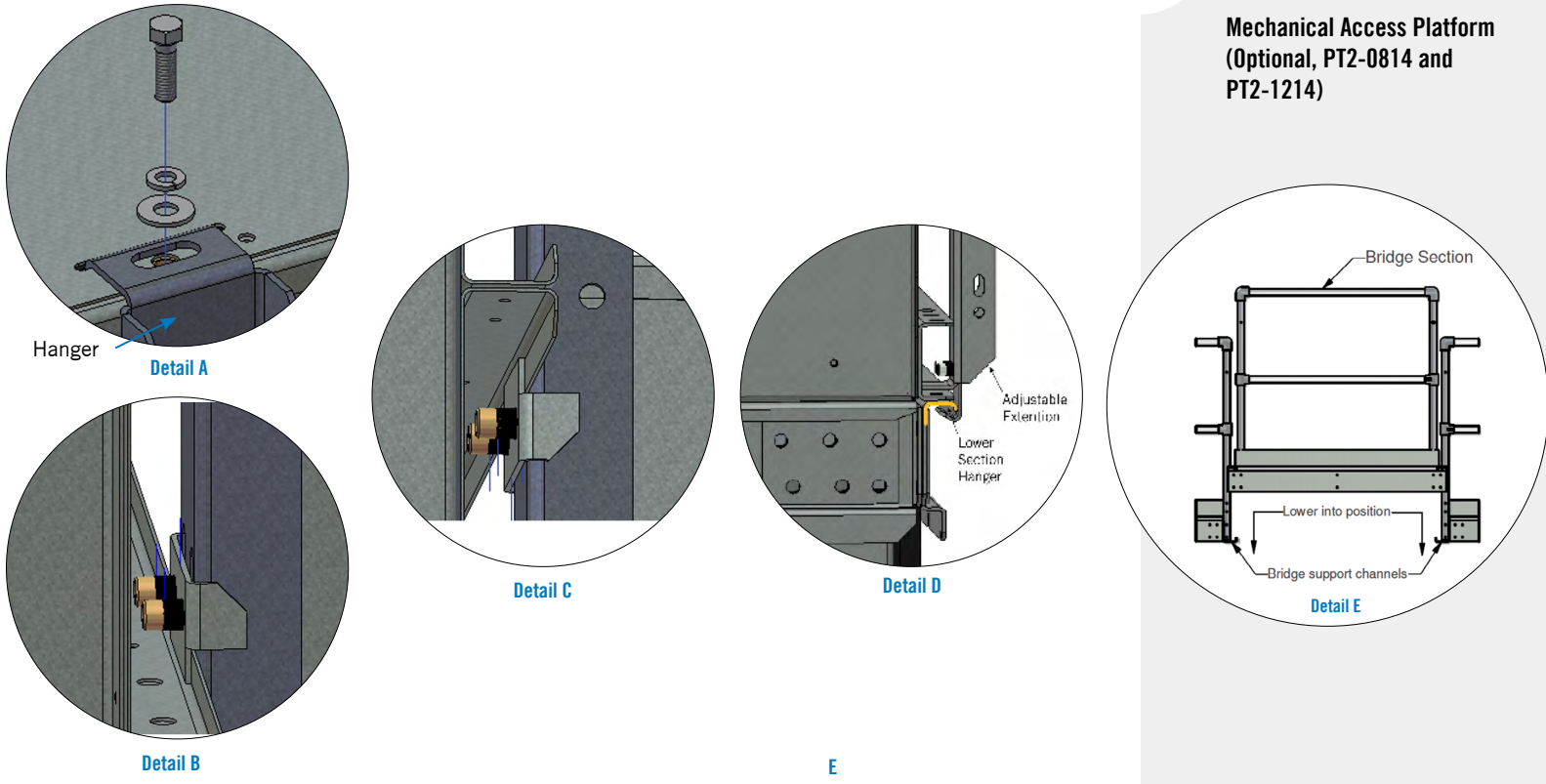

Figure 32. Mechanical Access Platform  
for PT2-1218 with One Fan and Three Cells

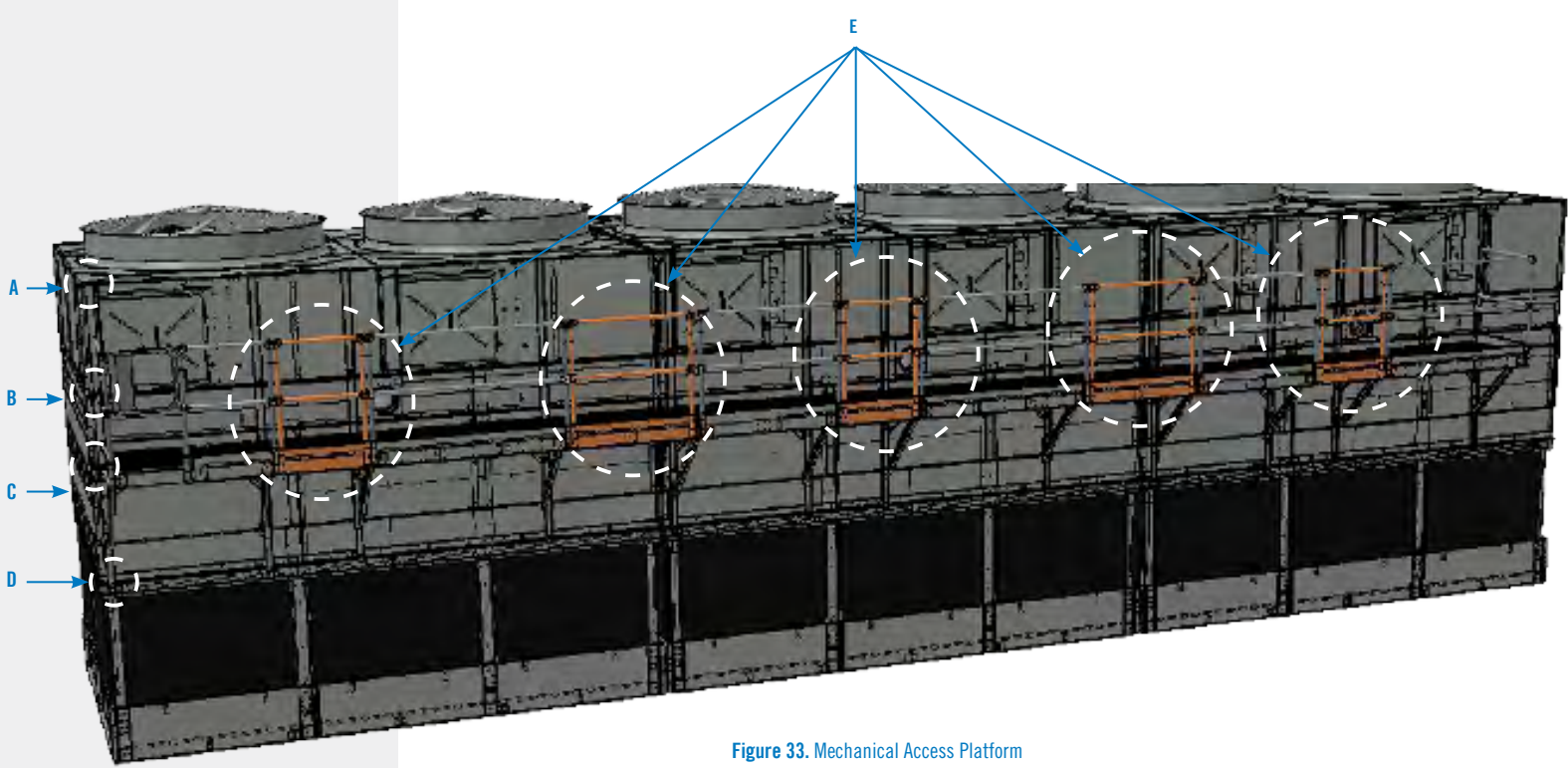
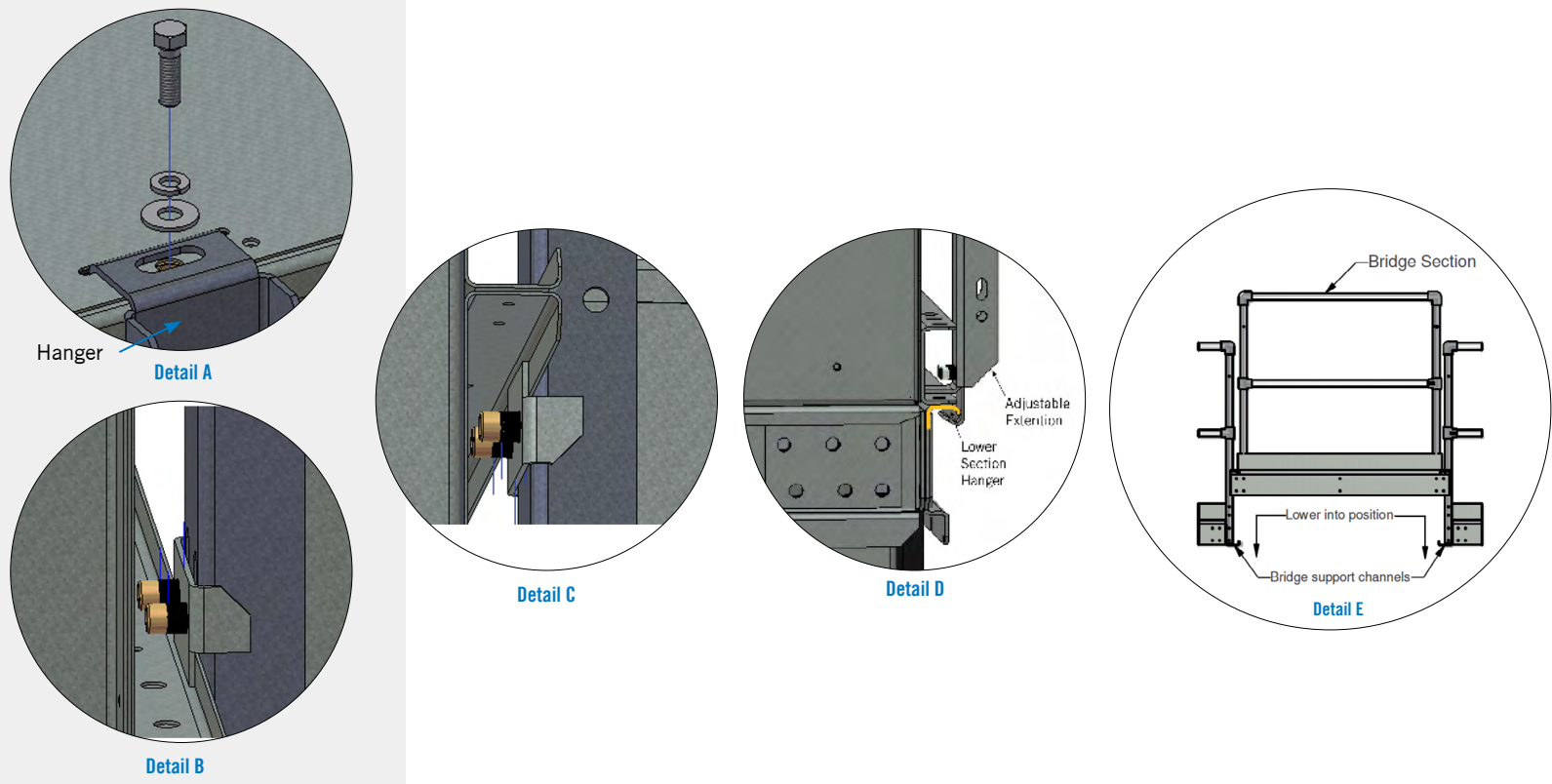

Figure 33. Mechanical Access Platform for PT2-1218 with Two Fans and Three Cells



## Mechanical Access Platform (Optional, PT2-0814 and PT2-1214)

Refer to **Figures 34 to 36** on **pages 25 to 27** for your unit platform assembly.

1. Lift the platform into place and align the platform support posts to the bracket. Secure the posts to the brackets using 3/8" bolts provided. See **Details A** and **B** on **Figures 34 to 36**.
2. For multi-cell units, install the connecting plates and toeboard as shown in **Figures 35** and **36, Detail C**, using the included #14x2" self drilling screws for the cover plate and 5/16" tappers for the toe boards.

**Mechanical Access Platform  
(Optional, PT2-0814 and  
PT2-1214)**

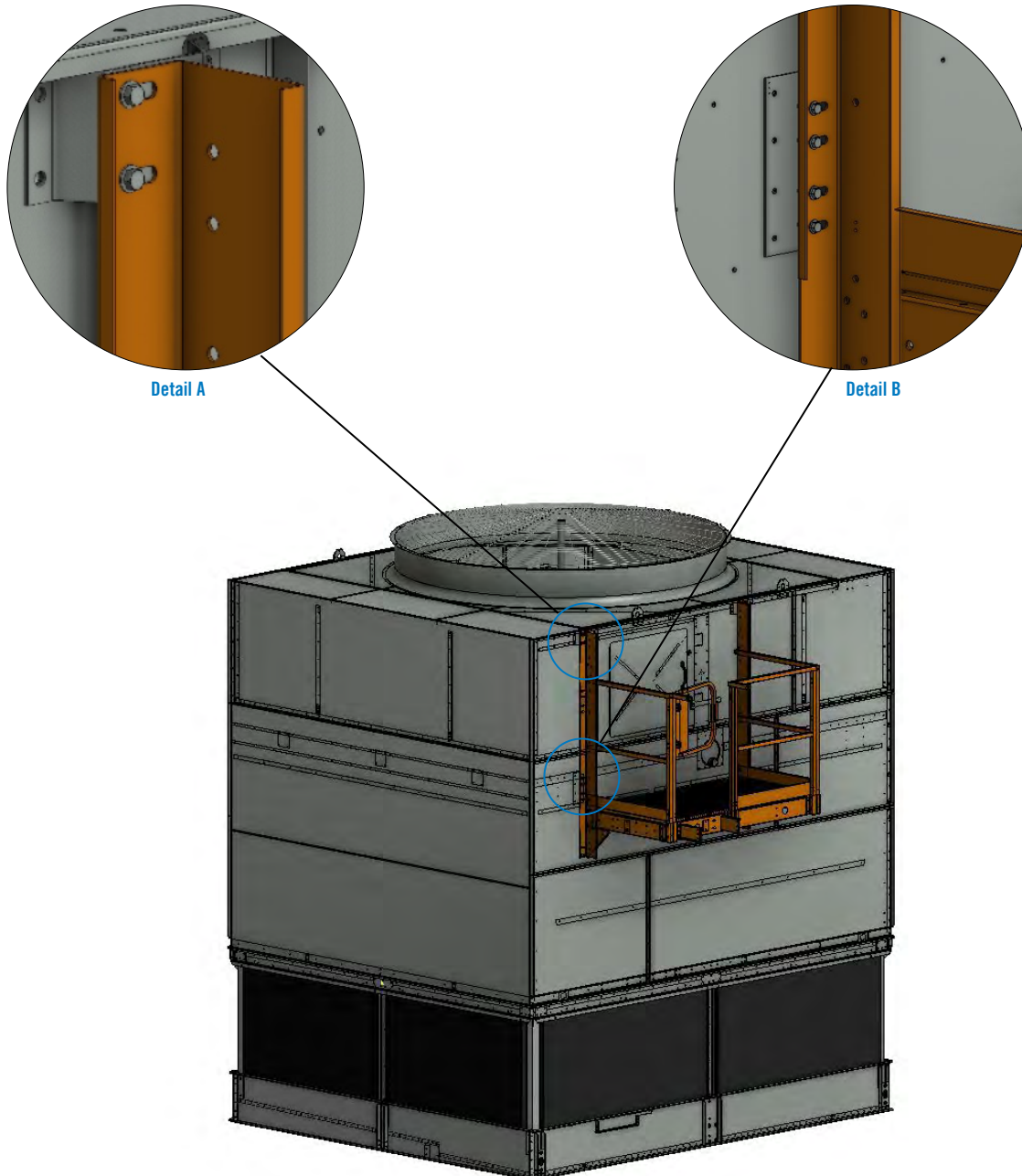

Figure 34. Mechanical Access Platform for One Cell PT2-0814 and PT2-1214 Units



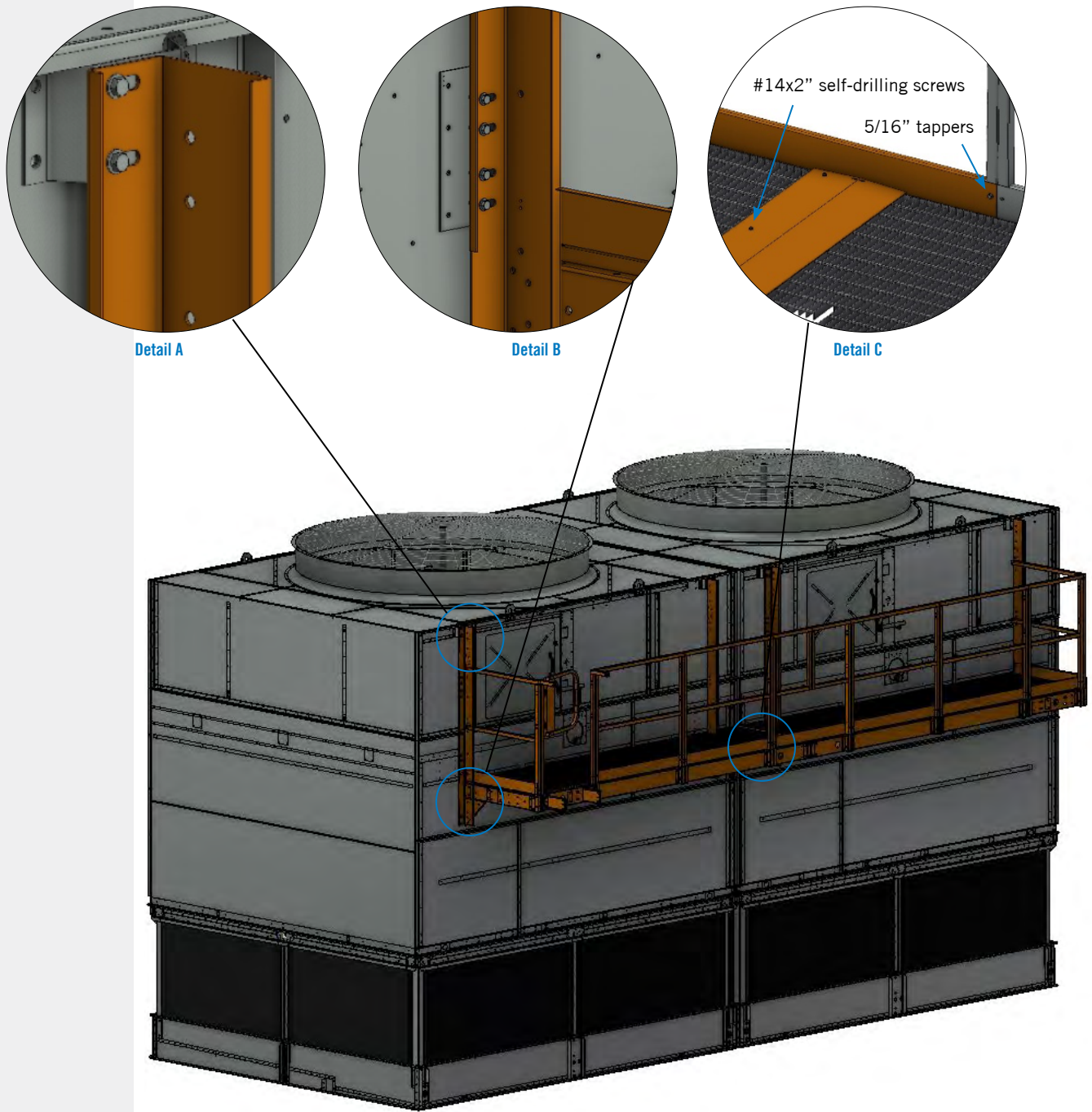

Figure 35. Mechanical Access Platform for Two Cell PT2-0814 and PT2-1214 Units

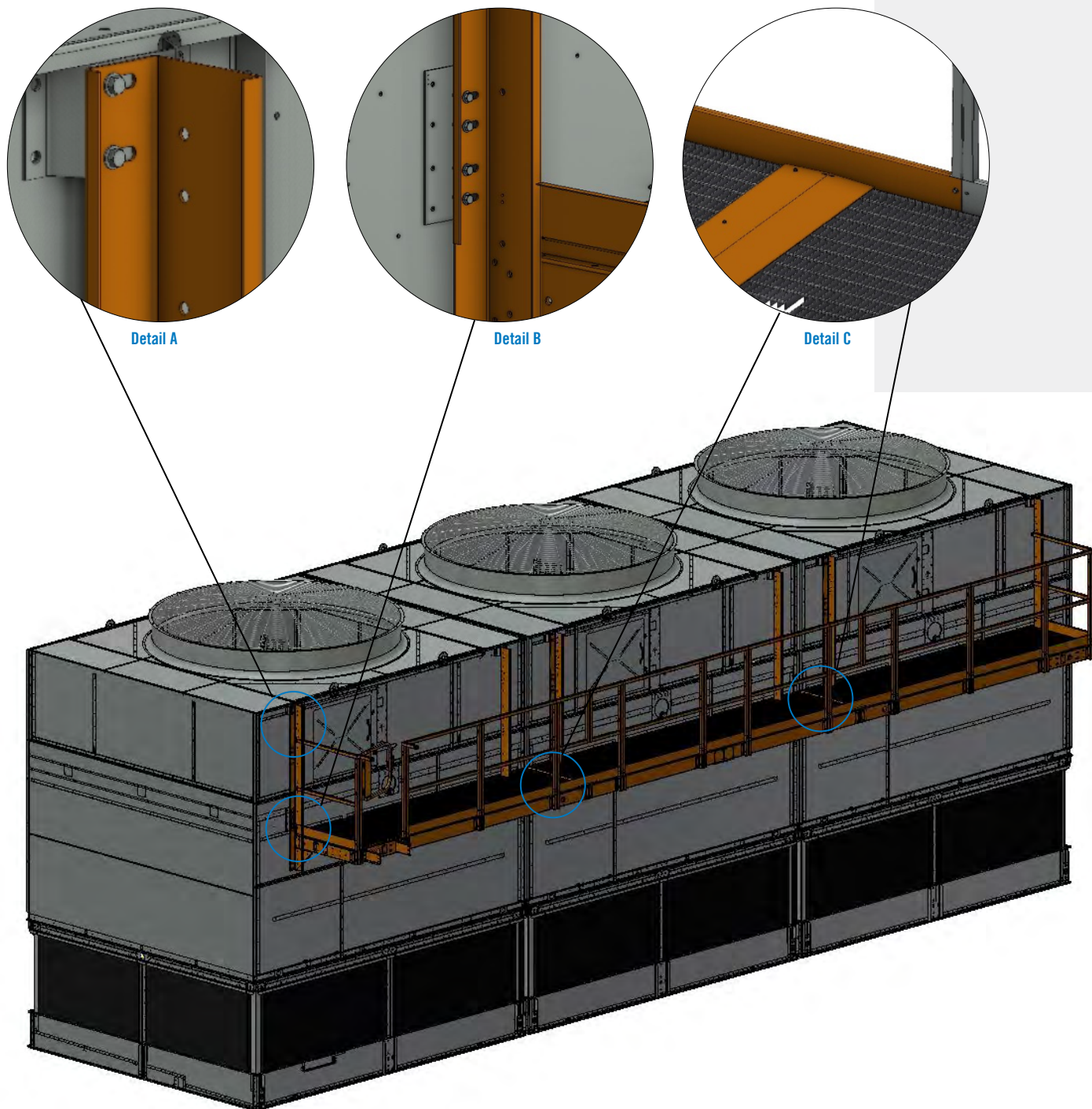

Figure 36. Mechanical Access Platform for Three Cell PT2-0814 and PT2-1214 Units

## Mechanical Access Platform Ladder (Optional)

1. Assemble the lower support assembly as shown and attach the assembly to the unit using the lower support bracket. See **Details C** and **D**. Use the next 3 figures, which are for 1-cell, 2-cell, and 3-cell figures, for the figure that corresponds to your platform option.
2. Attach the ladder to the platform utilizing provided bolts as shown in **Detail A** and **B** in **Figures 37, 38, or 39**. When securing ladder to unit, orient all bolt heads inside of the ladder and use flatwashers and locknuts on all fasteners.
3. Attach the lower support assembly using the ladder clips provided.
4. Check and tighten all ladder fasteners before using the ladder.

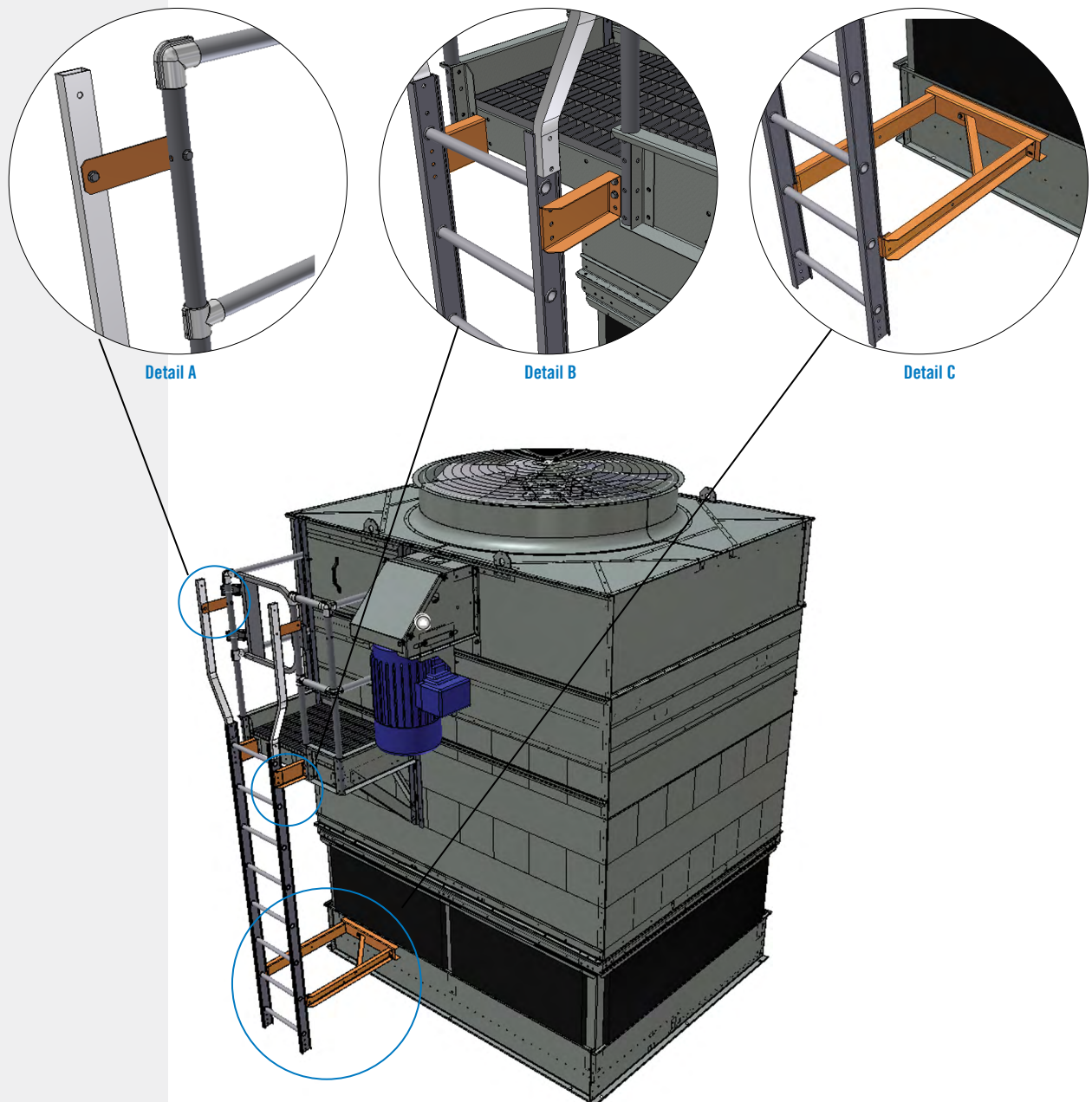

Figure 37. Mechanical Access Platform Ladder Installation for all Units Except for PT2-0814, PT2-1214, and PT2-1218 One Fan Units





## Optional Accessory Installation

### Mechanical Access Platform Ladder (Optional)

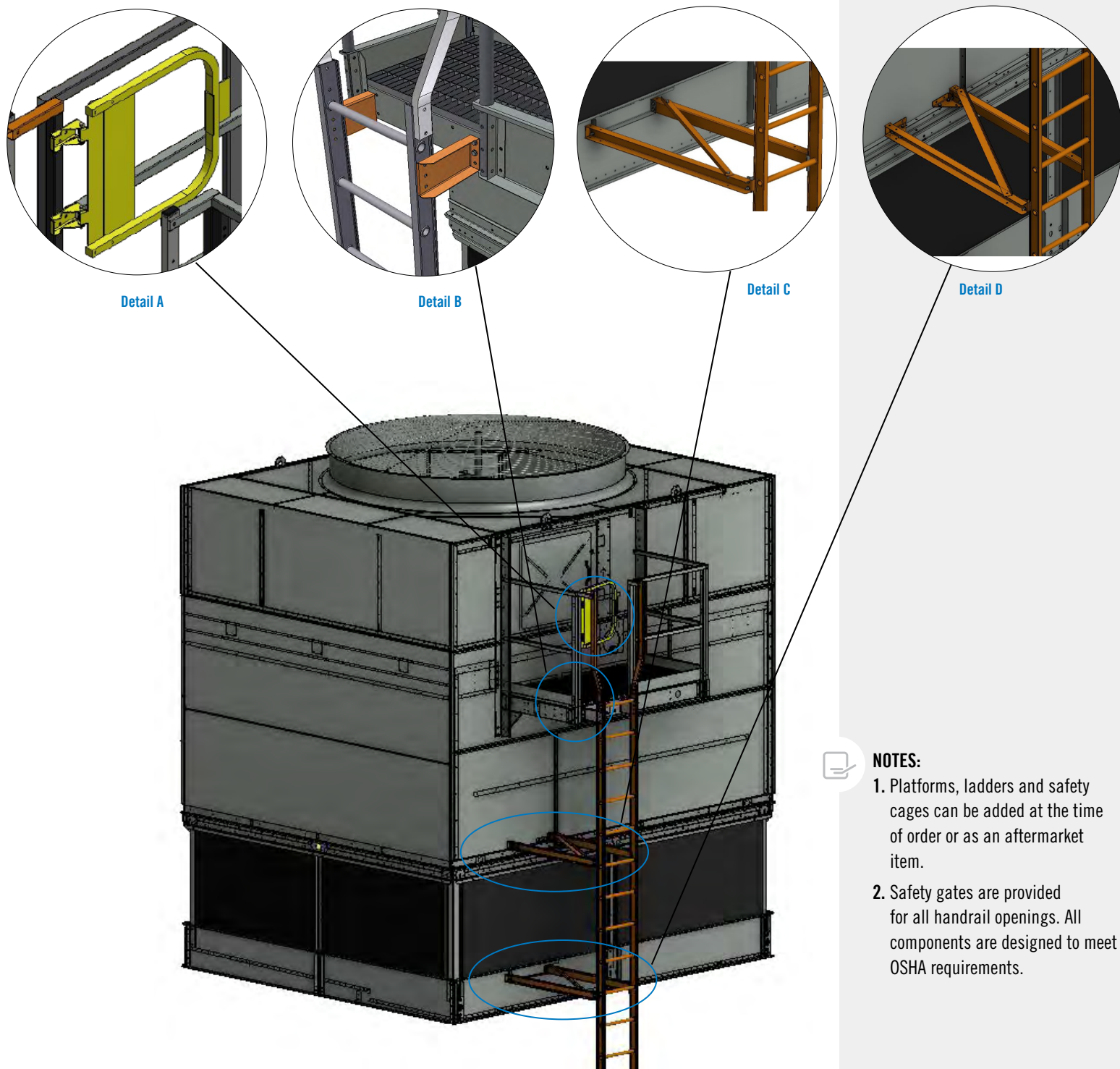

#### NOTES:

1. Platforms, ladders and safety cages can be added at the time of order or as an aftermarket item.
2. Safety gates are provided for all handrail openings. All components are designed to meet OSHA requirements.

Figure 38. Mechanical Access Platform Ladder Installation for PT2-0814 and PT2-1214

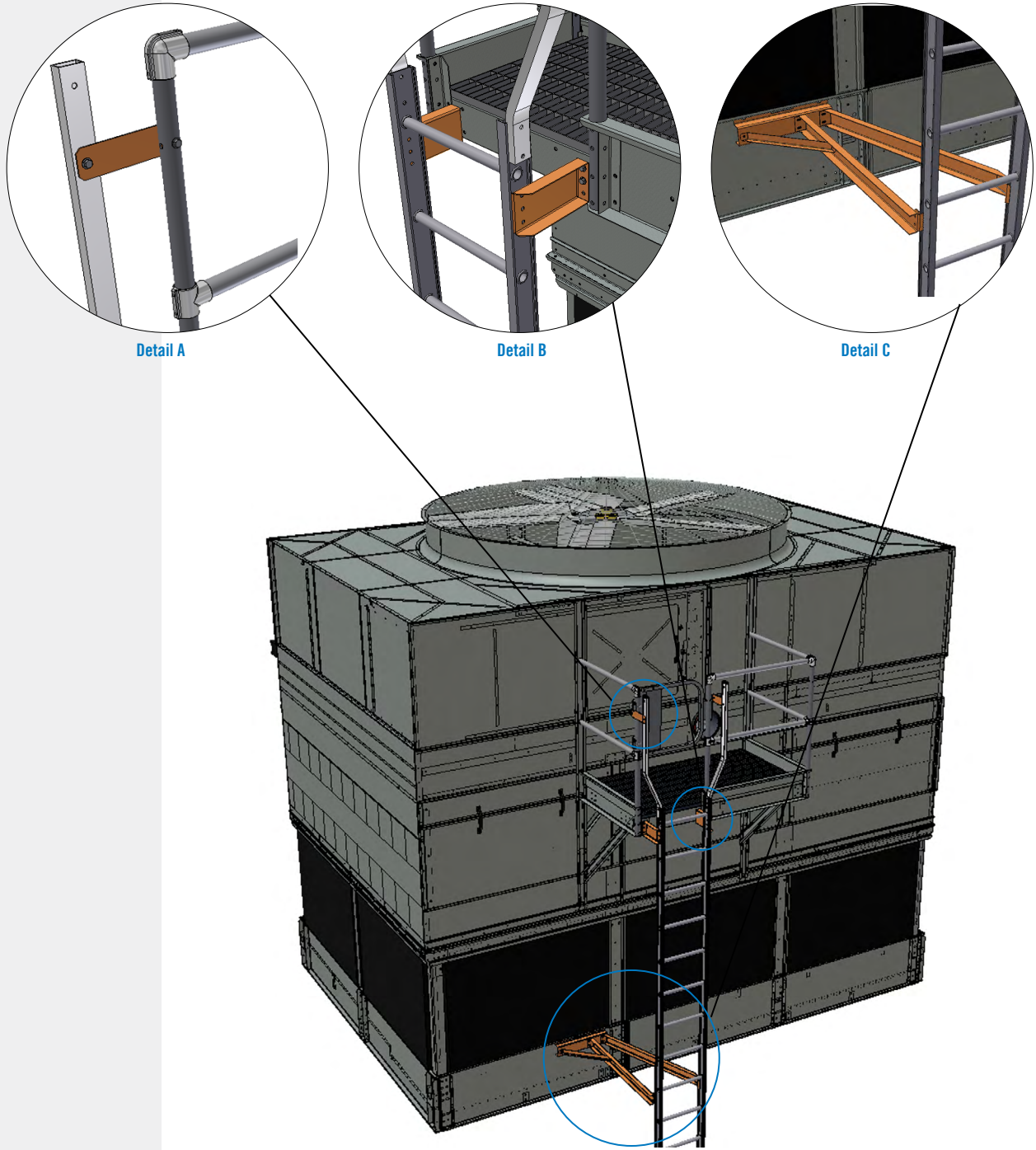

Figure 39. Mechanical Access Platform Ladder Installation for PT2-1218 One Fan Units



## Ladder Safety Cage (Optional)

1. If the safety cage is shipped in multiple pieces, reassemble the safety cage.
2. Bolt the safety cage to the ladder using flatwashers and locknuts. Orient all fastener with bolt heads inside safety cage. See **Figure 40, Detail A through D** and refer to **Table 3** for the quantity of bolting locations for different safety cage heights.

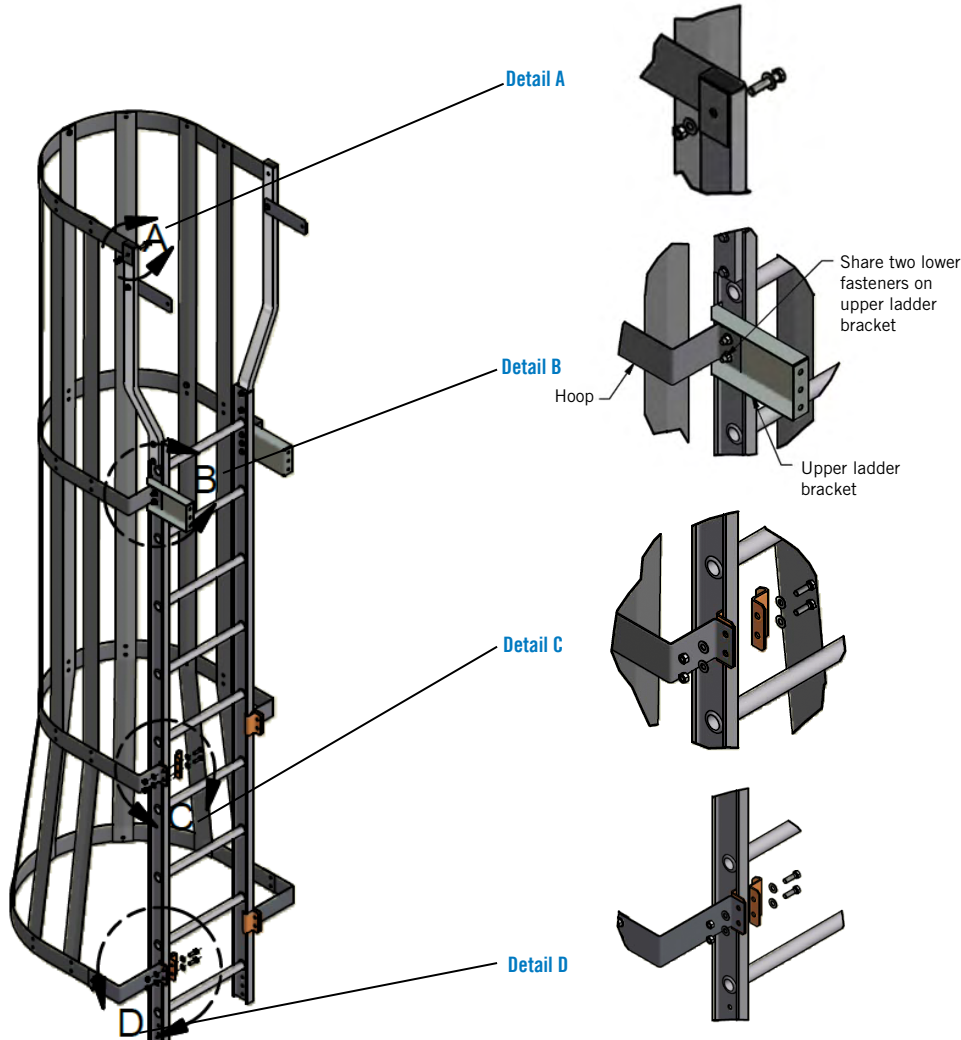

Figure 40. Safety Cage

Cage Height (ft)	Bolting Location				Cage Height (ft)	Bolting Location				Cage Height (ft)	Bolting Location			
	A	B	C	D		A	B	C	D		A	B	C	D
4	1	-	-	1	12	1	1	2	1	20	1	1	4	1
5	1	1	-	1	13	1	1	2	1	21	1	1	4	1
6	1	1	-	1	14	1	1	2	1	22	1	1	4	1
7	1	1	-	1	15	1	1	2	1	23	1	1	4	1
8	1	1	-	1	16	1	1	2	1	24	1	1	4	1
9	1	1	1	1	17	1	1	3	1	25	1	1	5	1
10	1	1	1	1	18	1	1	3	1	27	1	1	5	1
11	1	1	1	1	19	1	1	3	1					

Table 3. Ladder Safety Cage Bolting Location and Quantities



**NOTE:** Safety gates are provided for all handrail openings, and all components are designed to meet OSHA requirements.

**NOTES:** Bearing greasers and basin accessories can be added at the time of order or as an aftermarket item.



## Automatic Bearing Greasers (Optional)

1. Verify the mounting brackets are factory installed.
2. Fill the extended lube lines with BAC compatible water resistant grease using a manual grease gun. See the “Fan Shaft Bearing” section of the *PT2 Cooling Tower Operation & Maintenance Manual* available on [www.BaltimoreAircoil.com](http://www.BaltimoreAircoil.com).
3. Thread automatic bearing greasers into 3/8” x 1/4” adapters on mounting brackets.
4. For programming of the greaser, consult the manual shipped with the greaser.

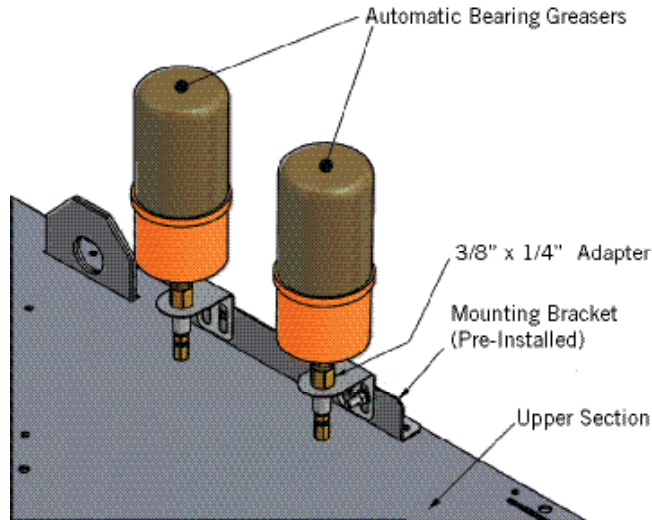

Figure 41. Automatic Bearing Greasers

### NOTES:

1. The heater control panel should be within sight of the heater if a disconnect switch option is selected.
2. Maintain a water level at least 2” over the heaters by ensuring proper operation of make-up water level control. Low water may lead to over temperature conditions near the heater.
3. All power wiring should have a temperature rating of 167°F (75°C), and be rated for the number of wires in the conduit.
4. The wiring should be sized for the quantity of incoming wires in the conduit and the amperage of the branch circuit protective device as directed by the NEC/CEC, or any other local directives.
5. If non-metallic conduit is used, provide a circuit grounding conductor that meets NEC/CEC requirements. Ground lugs are provided in the heater control panel.

## Basin Accessories (Optional)

Basin accessories are not factory installed and will be located in a box inside the unit or secured to the interior of the unit. Refer to the submittal drawings for basin accessory installation locations. Utilize an appropriate pipe thread sealant when installing accessories into basin fittings.

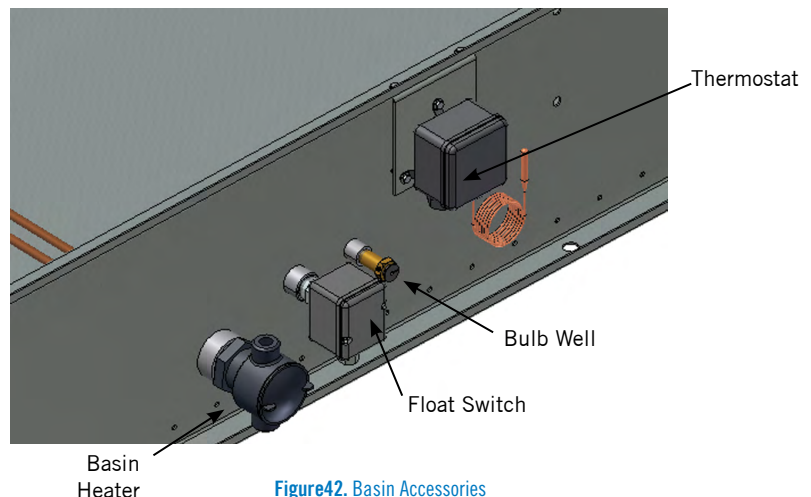

Figure 42. Basin Accessories

## Heater Control Panel (Optional)

1. Carefully plan the location of the control panel. Measure the factory supplied probe cord length. Do not attempt to change the cord length.





- After selecting the installation site, mount the control panel with four 5/16" (field supplied) bolts through the mounting feet on the enclosure.
- The main incoming power hub and the main power termination points are sized for wires based on the total nameplate kW and voltage. The actual load for a particular installation may be less. Either compute the actual load on the heater control panel (the total kW of all the heaters connected to it) or use the nameplate rating to determine the wire size required. The field supplied branch circuit disconnect switch and the branch circuit protective devices (fusing or circuit breaker) should be sized per NEC or local code requirements.
- Connect the incoming power wire conduit to the incoming power hub provided on the control panel. Make sure the connection is water tight and secure. Pull the incoming power wire into the control panel enclosure and make connections per the control panel-wiring diagram.
- Connect the heater power wire conduit(s) to the heater power wire hub(s) provided on the control panel. Make sure the connection is watertight and secure. Pull the heater power wire into the control panel enclosure and make the connections per the control panel wiring diagram. Conduit connections to multiple heaters should run until the conduit terminates at the last heater. Jumping from one heater to the next is not recommended.
- If the heater has a thermal cutoff, wire the cutoff back to the terminal block in the panel per the wiring diagram. This is a Class 1 circuit and can be in the same conduit as the power wiring. If there are two or more heaters, connect the cutoffs in series as shown in the wiring diagram.
- If alternative conduit hubs are drilled, or if supplied hubs are not used, replace the plastic protective caps inside the hubs with steel plugs.
- If leakage or condensation is likely to occur in the conduit runs leading to the control panel, install a drain in the bottom of the control panel and form a conduit loop.
- Verify operation by following the "Stand Alone BAC Heater Control Panel" in the *Common Operation & Maintenance Manual*.



**NOTE:** Figure 43 is superseded by any drawing supplied with the panel by the manufacturer.

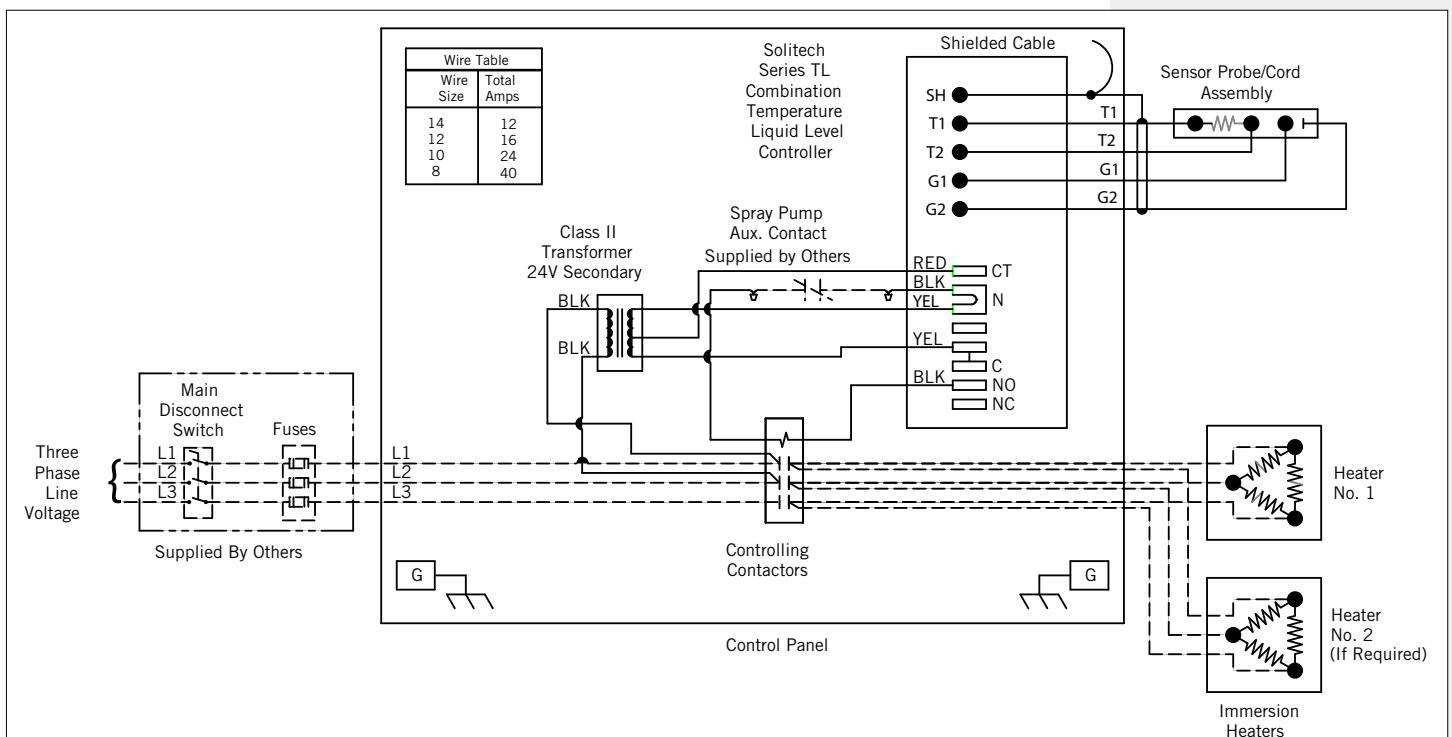

Figure 43. Example Wiring Diagram for Stand Alone BAC Heater Control Panel (Refer to Submittal Drawing for Specific Wiring Diagram)

## COOLING TOWERS

---

CLOSED CIRCUIT COOLING TOWERS

---

ICE THERMAL STORAGE

---

EVAPORATIVE CONDENSERS

---

HYBRID PRODUCTS

---

PARTS & SERVICES



[www.BaltimoreAircoil.com](http://www.BaltimoreAircoil.com)

7600 Dorsey Run Road, Jessup, MD 20794 › Telephone: (410) 799-6200 › Fax: (410) 799-6416

© 2022 Baltimore Aircoil Company › RGRAPT2A01-R242\_R2.0