

Cooling Tower Pumping and Piping

> Tower Pumping

Tower pumping does not present great difficulty in terms of good pump application. This is because of a normally high order of application safety factor. Troubles do occur occasionally, however, and these troubles can be classified as caused by:

1. Incorrect pump head estimation.
2. Pump cavitation and loss of pumping ability, as caused by inadequate pump suction pressure.
3. Air in pump suction; as caused by tower pan vortex, pan drain down or faulty bypass.
4. Unstable pump operational points as caused by:
 - a. Improper application of tower bypass controls.
 - b. High pressure drop tower spray nozzles in combination with tower bypass.
5. Inadequate maintenance procedures causing:
 - a. Plugged suction strainer.
 - b. Lack of tower treatment with consequent fouling of the condenser.

It is intended that each potential trouble source be evaluated so that the necessary design safeguards can be erected against operational problems.

Open “Tower” System Pump Head Requirements

The pumping head determination procedure for the “open” tower piping loop differs from the conventional “closed” loop piping circuit used for most Hydronic (Heat-Cool) applications. The difference concerns consideration of “open” loop static heads.

The closed loop circuit has no need for consideration of static heads for pump selection because of a balance or cancellation of static heads between the supply and return risers. Static head lost by water flow to any height in the supply piping is cancelled by a static head “regain” as water flows down the return piping. The only pump head requirement for the “closed” loop is that due to flow-friction pressure drop; static heights are not considered.

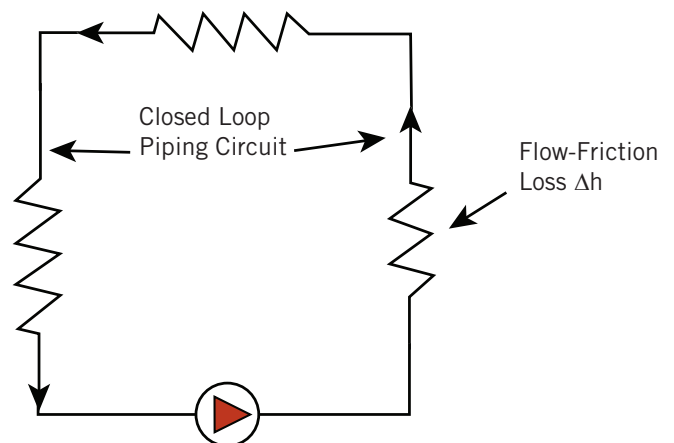

Figure 1. Static Height Not Considered for Pump Selection in Closed Loop



For the legend, see page J165.

The “open” or tower circuit is different from the “closed” loop circuit. The difference is that all static heads are not cancelable. In the open piping circuit, the pump must raise fluid from a low reference level to a higher level; this requires pump work, and open statics becomes an important consideration for pump selection.

In **Figure 2**, the required pump head will be the pipe flow-friction loss from A to D plus the energy head (H_s) required to raise water from the lower to higher level.

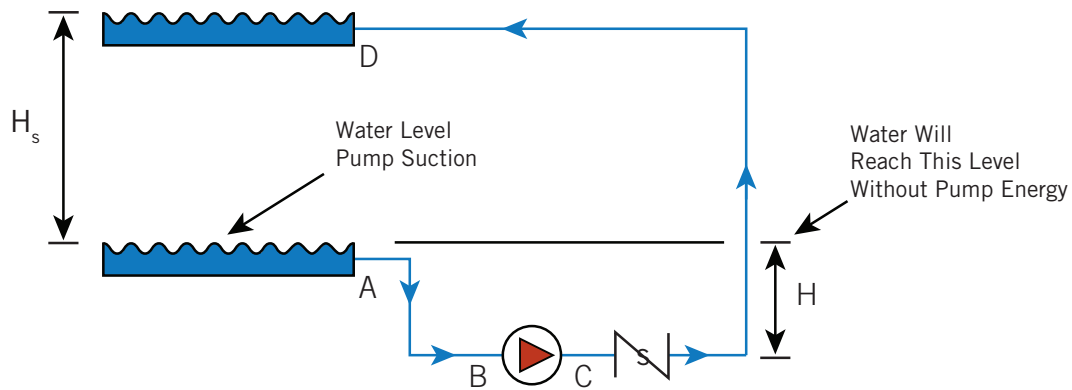

Figure 2. Open Piping Circuit

The cooling tower circuit differs slightly from the basic “open” circuit in that the discharge piping is connected directly to a distribution basin. Some towers are furnished with a distribution manifold with nozzles which require additional pressure.

For the tower piping circuit, the pump must overcome the piping flow friction loss; piping, condenser, cooling tower losses, and valves. It must also provide the energy head necessary to raise water from a low to a higher static head level.



Cooling Tower Pumping and Piping

Most discussions concerning tower and/or open piping circuits would simply define the required pump static energy head as H_o (in **Figure 3**); the “open” height of the piping circuit. This is, however, an ever-simplified assumption which may or may not be true depending on whether or not a “siphon draw” is established in the downcomer return piping DE.

The nature of the downcomer siphon draw and its limitations should be evaluated.

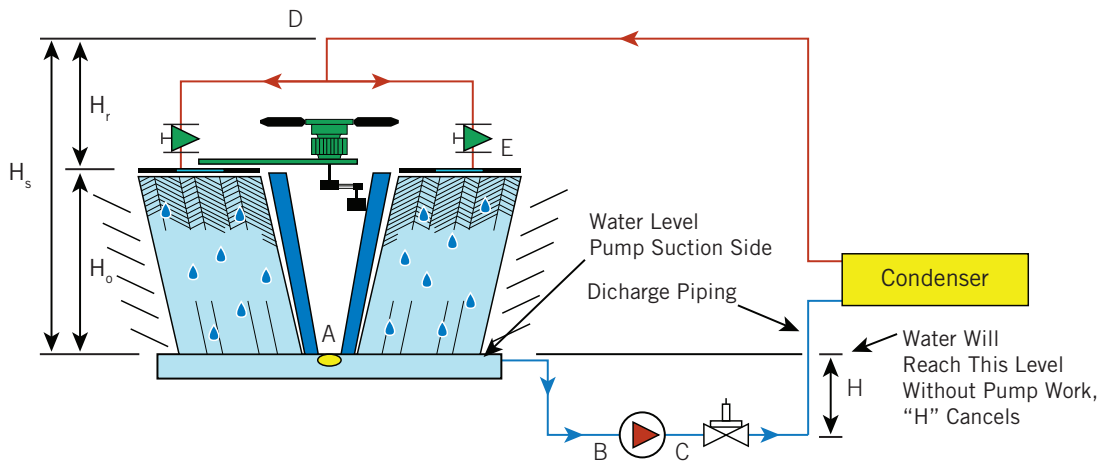

Figure 3. Typical “Open” Tower Piping Circuit

Downcomer Siphon Draw

In **Figure 3**, water is being discharged at E. Pressure at D must be equal to exit loss plus flow-friction loss DE and minus the static pressure reduction caused by downcomer return static height H_r .

Pressure reduction to D as caused by static height H_r will generally, but not always, permit cancellation of height H_r as a part of the required pump head. This is because of a resultant siphon draw action in the downcomer.

Given that the “siphon draw” does indeed occur, the required pump head will become:

$$\text{PUMP HEAD in Figure 3} = H_o + \Delta h (AE)$$

The pump head selection statement shown above is commonly accepted as a truism. It has limitations, however, and will not apply under certain circumstances. These circumstances should be understood if unnecessary cost and embarrassment are to be avoided by the consultant.

Exit loss and flow-friction loss in the downcomer will generally be less than the downcomer height H_r . For this circumstance the downcomer must operate at subatmospheric pressure when the siphon draw is established. If the downcomer vacuum is broken, the expected siphon draw will not occur and the estimated pump head may be inadequate.

The expected downcomer return siphon draw vacuum can be broken by any of three basic application circumstances:

- Top vented downcomer.
- Inadequate downcomer flow rates; bottom vented downcomer.
- Fluid vapor pressure or flash considerations.

Top Vented Downcomer

A downcomer vent will break the siphon draw vacuum. The vent may be a simple loose pipe connection - or it may be a mechanical vent purposefully applied at the downcomer return high point.

Vents are sometimes applied to establish known reference pumping conditions when downcomer return siphon draw conditions propose stability problems; as with a very high downcomer, when fluid boiling is a probability or when start-up downcomer flow rates are anticipated as inadequate for the siphon draw.

Given a top vented downcomer, it will be seen that the pump must raise water from the pump suction pan water level to the highest vented point in the downcomer.

Considering this point to occur at D in **Figure 3**, the required pump static head will become:

$$H_o + H_r \text{ or } H_s$$

The total pumping head to point D will become H_s plus the flow-friction loss Δh (AD). Separate consideration must now be given to the downcomer return.

Since the pump has raised water to level "D," it will have provided a fluid head equal to H_r to overcome flow-friction loss in the downcomer. There are two different pumping possibilities; fluid head H_r greater than downcomer flow-friction loss Δh (DE) and the reverse: H_r less than Δh (DE).

The usual pumping circumstance will be the condition of H_r greater than Δh (DE). This is because the available fluid head H_r is the equivalent of 100 ft / 100 ft pipe friction loss rate. Downcomer piping flow-friction loss will generally be to the order of 4 ft / 100 ft. Since the pump has already provided the necessary fluid head to flow the downcomer, $H_r > \Delta h$ (DE); friction flow loss in the downcomer is not a part of the required pump head and total pump head becomes:

$$\text{If: } H_r > \Delta h \text{ (DE)}$$

$$\text{Then: PUMP HEAD} = H_s + \Delta h \text{ (AD)}$$

High downcomer pressure drops can be caused by control valves or tower spray nozzles. When this pressure drop plus the downcomer pipe flow-friction loss exceeds fluid head H_r , the pump head must be increased by the difference Δh (DE) minus H_r . Total pump head then becomes:

$$\text{If: } \Delta h \text{ (DE)} > H_r$$

$$\text{Then: PUMP HEAD} = H_s + \Delta h \text{ (AD)} + [\Delta h \text{ (DE)} - H_r]$$



Cooling Tower Pumping and Piping

Bottom Vented Downcomer; Inadequate Flow Rates

Downcomer flow rates can be so low, relative to pipe size, as to allow air to enter at the pipe discharge. This circumstance will cause the downcomer to become vented and will prevent formation of the necessary siphon draw vacuum.

Tests conducted at Bell & Gossett indicate that the siphon draw will not be established when the actual flow-friction loss rate is less than the order of 1 ft /100 ft based on clean pipe pressure drop evaluation.

Pump head requirements for the bottom vented downcomer will be as previously noted for the top vented circumstance.

An unfortunate operational sequence can occur during pump start-up when the pump energy head is devoted towards simply raising water from the low level pan to the highest part of the system.

During this start-up period, flow rates can be so low as to cause “bottom venting” and prevent (sometimes forever) formation of siphon draw circumstances and full design flow rates. A water legged discharge or discharge reducer will provide automatic siphon draw establishment so long as minimum “start-up” flow velocity in the downcomer is to the order of 1 ft/s.

In **Figure 4**, air entry into the pipe discharge is prevented. The minimum flow velocity pulls air bubbles down the piping, finally evacuating the downcomer of air and establishing the siphon draw condition; downcomer pipe full of water and operating at subatmospheric pressure.

Unusual application circumstances will sometimes establish such a low start-up flow rate (less than 1 ft/s velocity) that air bubbles are not carried down the piping. The downcomer cannot then be emptied of air and expected siphon draw will never occur.

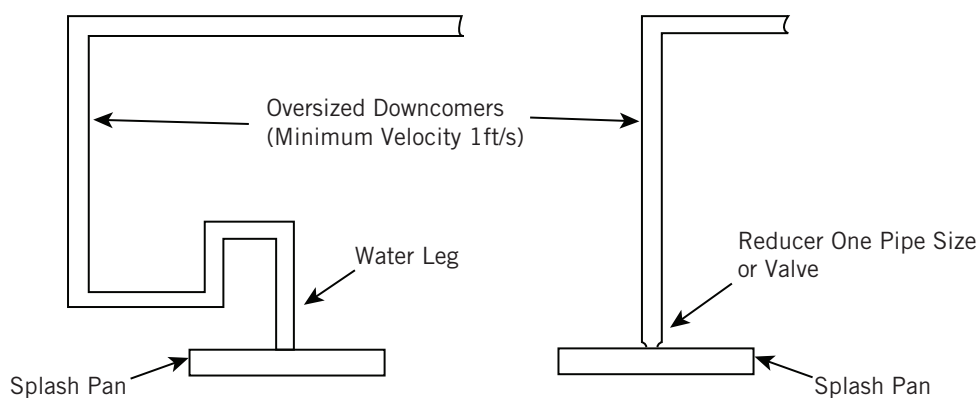

Figure 4. Water Leg or Reducer Help Establish Siphon Draw in Downcomer on Start-Up

For this circumstance it is necessary to separately fill the downcomer with water. This can be accomplished by valve closure at the piping exit in combination with a top vent. During start-up, the exit valve is closed and the vent opened. After the piping is filled, the vent is closed and the exit valve opened.

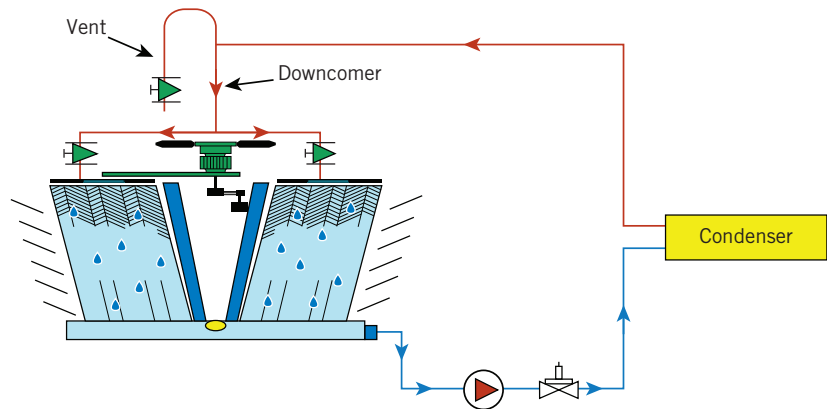

Figure 5. Exit Valve and Vent Permit “Start-Up” Fill of Downcomer Piping

Siphon Draw Limitation Due to Vapor Pressure; Fluid Boiling

Given sufficiently low subatmospheric pressure, any fluid will flash or boil. Fluid pressure in the downcomer piping cannot be less than the pressure at which the fluid boils. Fluid vapor pressure thus provides a siphon draw limitation.

Theoretical cancelable downcomer return static height (due to subatmospheric siphon draw) will vary dependent on fluid vapor or boiling pressure and on atmospheric pressure as this changes from sea level. The variation for water as affected by water temperature and height above sea level is shown in **Table 1**.

Height Above Sea Level (ft)	Water Temperature (°F)						
	Cold	105	120	140	160	180	200
0	34.0	31.8	30.0	27.6	23.4	17.0	7.7
1,000	32.8	30.1	29.0	26.4	22.2	15.8	6.4
2,000	31.6	29.1	28.0	25.3	21.0	14.6	5.2
3,000	30.2	28.2	26.8	24.1	19.9	13.5	4.03
4,000	29.2	27.0	25.6	23.0	18.7	12.2	2.82
5,000	28.0	25.6	24.4	21.8	17.5	11.1	1.61
6,000	26.9	24.6	23.2	20.6	16.4	10.0	0.48
7,000	25.8	23.4	22.2	19.4	15.2	8.8	—
8,000	24.6	22.2	21.0	18.2	14.0	7.6	—
9,000	23.4	21.1	19.8	17.1	12.9	6.4	—
10,000	22.2	19.9	18.6	15.9	11.7	5.2	—

Table 1: Maximum Theoretical Downcomer Return Cancelable Static Height (In Ft) Because of Siphon Draw - Water Only



Cooling Tower Pumping and Piping

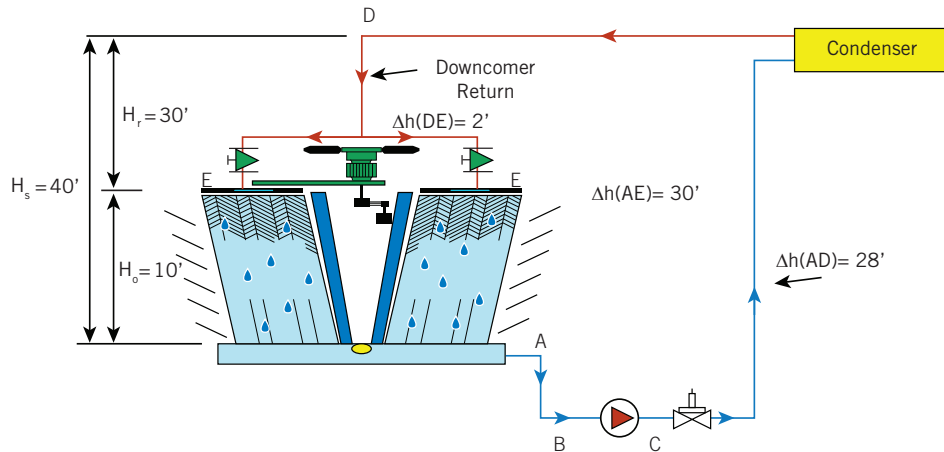

Figure 6. Example Problem

Example Problem

Figure 6 illustrates an example tower schematic for an installation located at 6,000 ft elevation. The tower is to be used to dissipate heat from 180°F water; what is required pump head?

- Figures shown correspond to available fluid head over and above vapor pressure for the water temperature shown.

Reference to **Table 1** shows that the cancelable siphon draw height for 6,000 ft elevation and 180°F water is only 10 ft, while downcomer return static height is 30 ft.

If conventional pump selection practice were to be followed, the pump selection would be:

$$\begin{aligned}
 \text{WRONG PUMP HEAD} &= \Delta h(AE) + H_o \\
 &= 30 \text{ ft} + 10 \text{ ft} \\
 &= 40 \text{ ft}
 \end{aligned}$$

It will be noted that this pump selection provides a perfect example of low start-up flow rates; the pump head will just be enough to raise water to the system top. Start-up flow rate will be insignificant.

Even given the special application precautions previously stated, however, the pump selection would not work. This is because water flash in the downcomer will prevent establishment of the presumed 30 ft siphon draw head. In this instance, water would flash because the downcomer return static height exceeds the cancelable siphon draw head (see **Table 1**; 6,000 ft at 180°F = 10 ft).

When downcomer return height exceeds cancelable siphon draw head, it is necessary to separately evaluate downcomer needs. For these circumstances:

The summation of cancelable siphon draw static height plus downcomer return flow-friction loss must exceed downcomer return height; the excess providing anti-flash pressurization.

The necessary downcomer flow-friction loss would generally be established by a balance valve positioned close to the outlet (E). This valve will now provide the necessary “back pressure” to maintain downcomer fluid pressure at above its boiling or vaporization point.

For the particular example, a valve pressure drop equal to the order of 23 ft would establish an overall downcomer return flow-friction loss of 25 ft ($23 + 2 = 25$ ft).

A 25 ft downcomer flow-friction loss added to the theoretical cancelable height of 10 ft (**Table 1**) will establish a pressure over and above boiling of 5 ft at “D.”

$$25 \text{ ft} + 10 \text{ ft} = 35 \text{ ft}; 5 \text{ ft over static height } H_r = 30 \text{ ft}$$

The correct pump head selection now becomes:

$$\begin{aligned} \text{PUMP HEAD} &= \Delta h (\text{AD}) + \Delta h (\text{DE}) + \Delta h (\text{Valve}) + H_o \\ &= 28 \text{ ft} + 2 \text{ ft} + 23 \text{ ft} + 10 \text{ ft} \\ &= 63 \text{ ft} \end{aligned}$$

For this particular example, a simpler solution could apply an open vent at “D”, eliminating need for the downcomer balance valve and its setting.* Required pump head would then become:

$$\begin{aligned} \text{PUMP HEAD} &= \Delta h (\text{AD}) + H_o + H_r \\ &= 28 \text{ ft} + 10 \text{ ft} + 30 \text{ ft} \\ &= 68 \text{ ft} \end{aligned}$$

Either correct solution will provide required design flow rates. Design flow rates would not and could not be established by the “conventional” head selection of 40 ft.



NOTE: In this case, the pump provides an “available” head at D of 30 ft. This fluid head is available for downcomer flow and is greater than flow-friction loss in the downcomer (Δh DE) of 2 ft. Downcomer return flow-friction loss can then be neglected since downcomer fluid will be in “free fall.”

> Pump Curve Maintenance

In order for a pump to fulfill its fluid flow function, it must be provided with a solid stream of fluid. The centrifugal pump cannot pump fluid and vapor or fluid and air and still provide flow in accordance with its published curve.

- The pump suction must be under enough pressure so that vapor flash pressure within the pump (cavitation) is prevented.
- The pump cannot be expected to provide design flow when large quantities of air are drawn into the pump suction; as by tower pan vortex, pan draw-down, or bypass vacuum.



Reprinted with permission from Xylem, Inc. Copyright 2013.

Cooling Tower Pumping and Piping

In addition to flow capacity reduction, the pump will often be mechanically damaged by “shock” loads applied to the impeller or its shaft because of cavitation or air in the suction line.

Large quantities of air in the suction line will break pump shafts in remarkably short order. This is because the pump impeller alternates between virtually no load when an air “gob” enters the impeller casing and an instantaneous shock load of very high order when it slugs against suddenly introduced water.

There are three basic ways for air to be drawn into the suction piping:

- Tower bypass into pump suction line.
- Pan drain-down on start-up.
- Tower vortex.

Tower Bypass Into Suction Line

Improperly applied tower bypass lines connected directly to the pump suction line can cause introduction of large amounts of air into the pump. Air can be drawn into the pump suction when subatmospheric pressures exist at the bypass and discharge line connections.

When the tower illustrated in **Figure 7** is in full bypass, pressure at “B” will be above atmospheric pressure by an amount stated by static height H_1 . Pressure at “C” can become subatmospheric, causing air suction unless static pressure reduction caused by height H_2 is counter-balanced by an equal to or greater flow-friction loss in the bypass line.

The bypass control valve and bypass piping should be designed for sufficient pressure drop to prevent subatmospheric pressure at “C” and to cause water to rise into the water leg when the tower is in bypass.

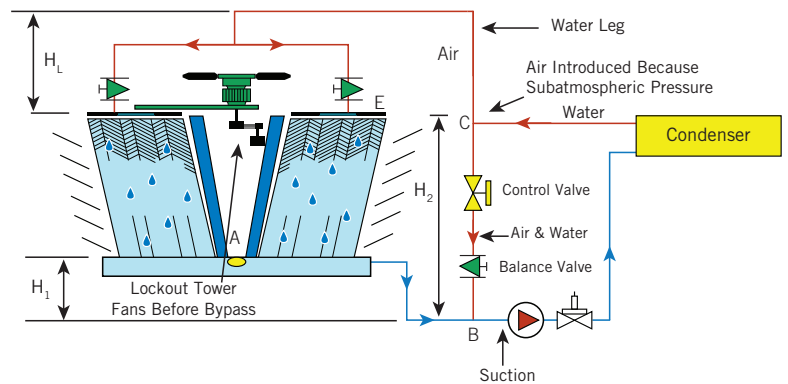

Figure 7. Tower Bypass Can Introduce Air into Pump Suction on Full Bypass - **NOT RECOMMENDED**

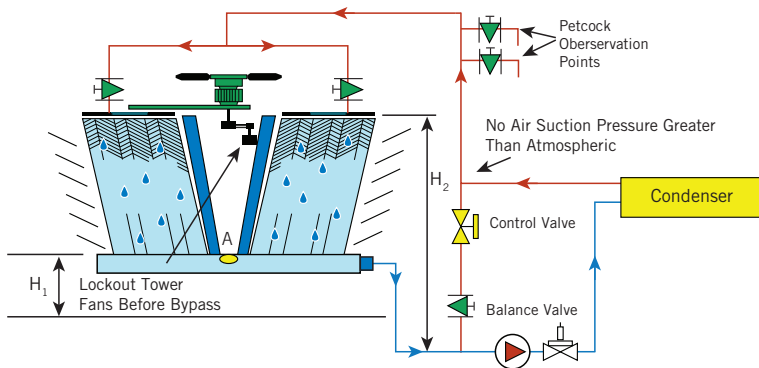

Figure 8. Properly Set Balance Valve Prevents Air Suction into Pump - **NOT RECOMMENDED**

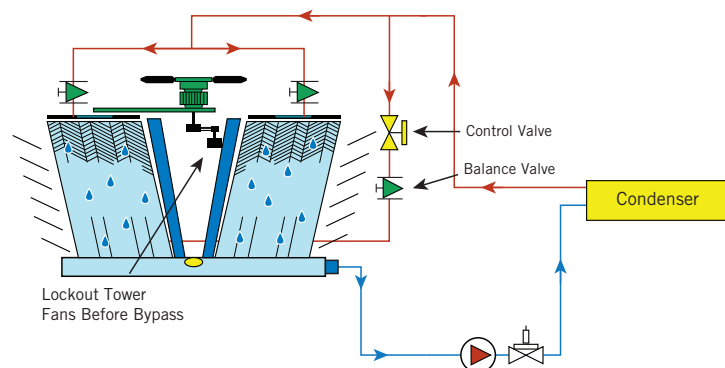

Figure 9. Bypass to Tower - Preferred Bypass System

The desired result will generally be obtained by use of a bypass balance valve with the valve so set that at full tower bypass (**Figure 8**), bypass “back pressure” causes water to rise into the water leg to some set point as established by a petcock design observation point.

It should be noted that tower bypass directly into the tower pan eliminates any possibility of air suction into the pump because of bypass operation and is generally preferred.

Figure 9 illustrates a way of by-passing into the tower pan.

Pan Drain-Down On Start-Up

Many tower pans do not contain sufficient water volume to fill the condenser piping. On pump start-up, the pump can drain the pan dry or lower pan water level to the point of starting a vortex. In either event, air will be drawn into the pump suction; usually with disastrous results.

Right and wrong applications are (**Figures 10** and **11**) shown concerning the pan drain-down problem.

In **Figure 10**, the pump must fill the condenser, and all return piping each time it starts. In addition to a non-flooded condenser on start-up, the pipe and condenser water fill requirement will almost assure pan drain-down and consequent suction line air problems.

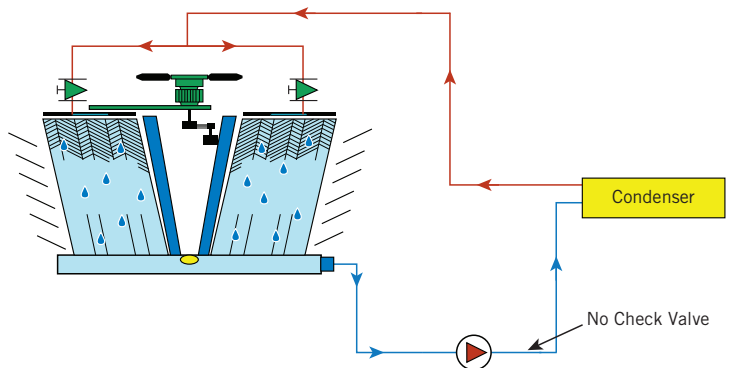

Figure 10. Tower Piping and Condenser Drains into and Overflows Pan on Pump Shut-Down - **WRONG**



Cooling Tower Pumping and Piping

In **Figure 11**, the check valve prevents back drainage of the vertical tower piping, while the water leg prevents drainage of the inside horizontal return piping.

As a general rule, tower piping systems should be fitted with a piping fill line located at the check valve discharge. The fill line will provide two functions:

1. It permits filling of the condenser piping independent of the tower pan and pump. The hazards of pan drain-down on initial pump start-up can be avoided.
2. It is important on chiller start-up that the condenser be flooded on the tower side. Many condensers are located above the tower pan water level and additional insurance as to a flooded condenser under these conditions can be provided by use of an automatic fill or Pressure Reducing Valve. This valve would be set to maintain fill to just below the topmost piping point.

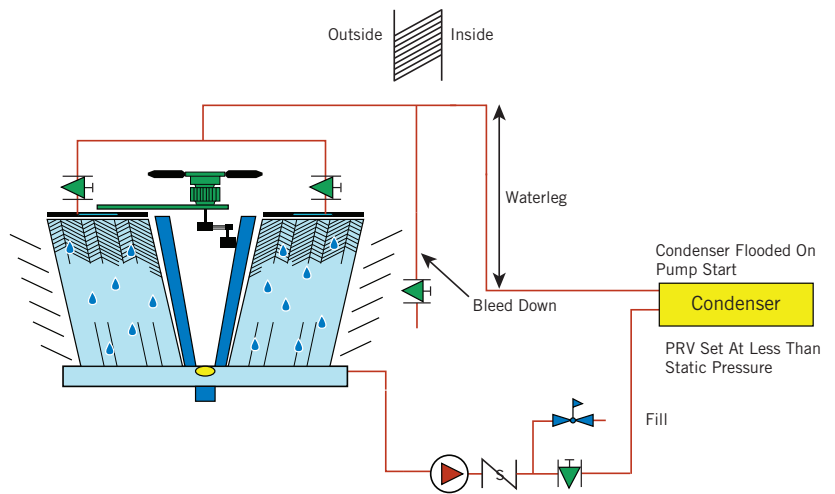

Figure 11. Check, Water Leg and Fill Prevent Piping to Tower Drainage - **RIGHT**

Use of the Pressure Reducing Valve also guards against back drainage problems as caused by a leaking check valve.

In **Figure 11**, it will be noted that the bleed blow-down is located in the top horizontal return piping run. Bleed will only occur during pump operation. The top or “outside” horizontal return piping will always drain to the tower and location of bleed blow-down in this line is to be recommended.

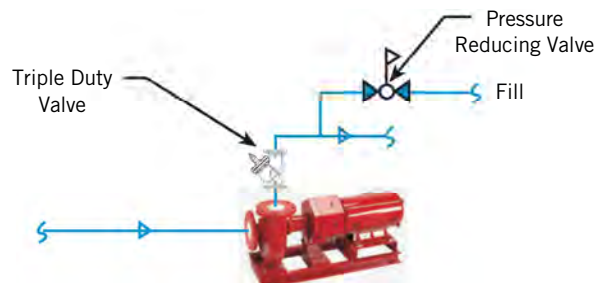

Figure 11A. Location of Fill Valve with a Multi-Purpose Valve-Reference (Figure 11)

Tower Vortexing; Excessive Exit Velocities

Solution of the back drainage problem does not necessarily solve all pump suction line air problems. Tower vortexing may still occur when tower pan water level over the pan outlet is insufficient for the flow rate (outlet or exit velocity) actually taking place.

Tower manufacturers often provide vortex breakers in the tower pans and would generally be able to guarantee non-vortex operation up to some stated flow rate for a particular tower, its pan and pan exit pipe size.

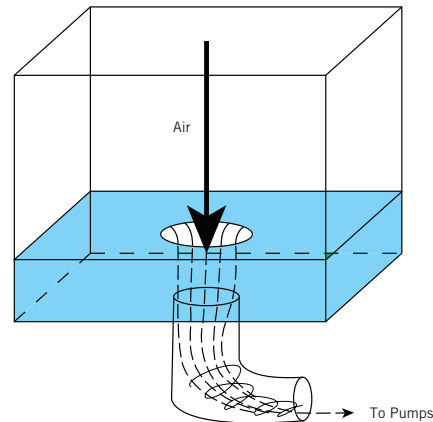

Figure 12. Tower Vortexing

In some cases, pump suction line pipe size may be less than pan exit size. Given a bushed down pan exit, exit velocities may become so high as to cause vortex. Tower exit pipe size should conform to pan exit size for the order of 10 pipe diameters before reducing to the smaller pump suction line size in order to insure that intended tower exit velocities are not exceeded.

It would seem important that the engineer state, as a part of his tower specification, that the tower be able to operate without vortex to the design flow rate plus some reasonable increment. It would then be the engineer's responsibility to provide a pump and piping system combination that establishes some reasonable facsimile of design flow; at least not to exceed the tower manufacturer's requirements.

There are several problems:

1. The initial pump selection head may be overestimated; the less than estimated head causing a flow increase. In this case, use of the throttle or balance valve illustrated in **Figure 11** is to be highly recommended.
2. Improper application of tower bypass controls can cause highly variable pumping points and flow increase possibilities.

Uncontrollable flow increases cannot only cause tower vortex problems, but are also a trouble source concerning pump cavitation.

Design application points concerning stable pump operation will be evaluated after consideration of the suction line pressure drop or cavitation problem.



Cooling Tower Pumping and Piping

> NPSH; Cavitation

It is well known that fluids boil at defined temperature-pressure relationships. For any given fluid at a given temperature, pressure reduction to some stated value will cause boiling or vaporization.

A pumped fluid can vaporize or flash within the pump itself because of inadequate pressurization. Fluid vaporization within the pump is generally defined as cavitation and can cause trouble as follows:

1. Pump impeller damage will occur. This is because low pressures in the impeller “eye” will cause vapor bubble formation. The vapor bubbles then collapse or “implode” because of the pressure increase as the bubbles move into higher pressure areas inside the impeller. These hammer-like blows against the impeller can cause physical destruction within a short time.
2. The pump curve will change drastically and in an unpredictable manner. Flow can virtually cease or “slug” because the pump cannot readily deliver both fluid and vapor.
3. Pump shafts can be broken because of slugging of the impeller against alternate bodies of fluid, vapor, and air.
4. Mechanical pump seal failure can occur because the mechanical seal is asked to work under intolerable conditions; vapor flash around the seal causes “dry” operation and rapid wear.

It is most important to successful pump application that adequate (above vaporization) pressures be maintained within the pump.

The engineering tool used to insure adequate anti-flash pressurization is a term defined as “Net Positive Suction Head” (NPSH). NPSH is a rather abstract term which has been subject to much misunderstanding. Before defining NPSH, it will be worthwhile to establish why the term is necessary.

All pumps operate at a lower pressure in the impeller eye and inlet to the impeller vanes than the pressure existing at the pump suction flange. Even though pressure at the pump suction flange is measured and known to be above the flash or vaporization point, the pump can still cavitate because of the pressure reduction that exists from the suction flange to the pump interior.

Internal pump pressure drop occurs because of greatly increased fluid velocities from the pump suction flange to and through the impeller eye and because of turbulence, vane entrance friction losses, etc. In order to prevent cavitation, then, the application engineer must know how much internal pump pressure drop will occur for his design circumstances and for any of a number of specific pump selection possibilities.

The pump manufacturer’s measure of this pressure reduction is called “Required NPSH”.

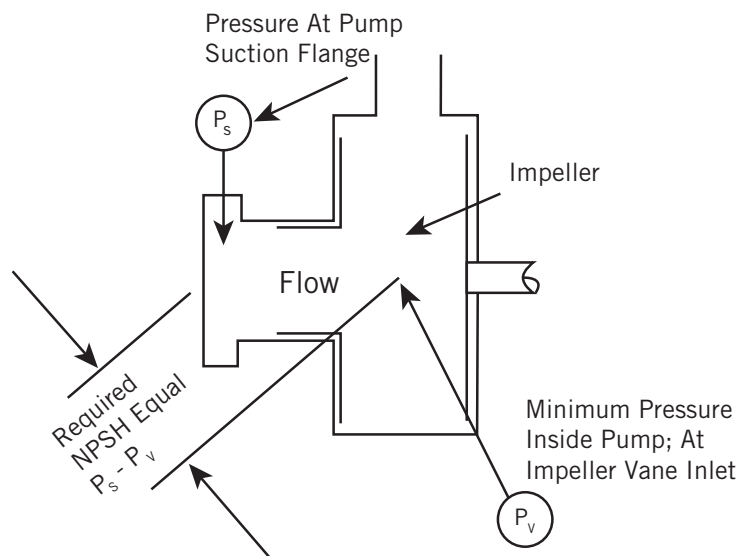

Figure 13. Required NPSH is Measure of Pump Pressure Drop

Test procedures for establishing Required NPSH have been standardized and are carefully followed by pump manufacturers so as to obtain as true an estimation of internal pump pressure drop as possible.

Required NPSH is illustrated on pump curves by several different methods. **Figure 14** shows a separate curve plot of Required NPSH. This type of illustration is used when only a single pump capacity curve is shown.

Regardless of the illustration method, Required NPSH is not a constant value for any pump. Similar to valve pressure drop, Required NPSH will increase with flow increase.

Again, referencing to valves, it is well known that for a given flow rate, a large valve will cause less pressure drop than a smaller valve. In a similar manner, pumps can be considered as small or large by reference to impeller eye diameter for intended pumped flow rate. For the same pumped flow rate, a small pump (small impeller eye diameter) will have a much higher Required NPSH than a larger pump.

Figure 15 provides some important basic pump application points.

1. Pumps selected to the end of the capacity curve (Ft Hd vs. GPM) are being driven to maximum capability and are the smallest pump that can provide design flow rate. The pump is “small” however, and establishes a maximum Required NPSH (pump pressure drop).

While generally lowest cost, because of minimum size, the selection establishes maximum trouble potential.

2. Pumps selected to the midpoint area of the capacity curve are larger; impeller eye velocity is reduced and the pump internal pressure drop must be lower.

The pump so selected will cost more than the minimal “end of curve” selection but will reduce trouble potential when NPSH or cavitation problems are a consideration.

It should be noted, in passing, that many potential pump application problems other than cavitation are reduced by midpoint selection: flow balance, noise, etc.

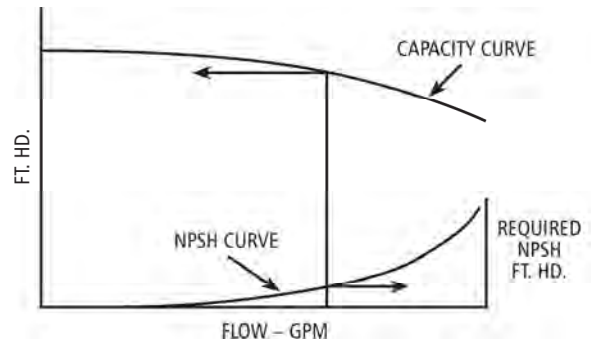

Figure 14. Required NPSH Increases as Flow Increases Through Pump

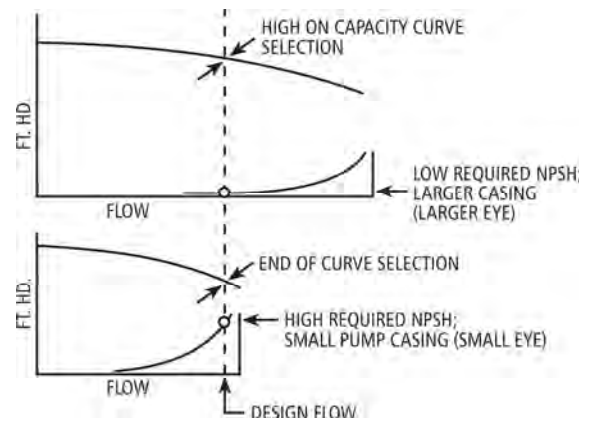

Figure 15. Difference in Required NPSH for Same Flow Most Often Determined by Pump Size





Cooling Tower Pumping and Piping

We have thus far established a basic point; that Required NPSH is a description of a specific pump's internal pressure drop as flow rate through the pump changes. How is knowledge of Required NPSH used for specific pump application problems?

The fundamental manner in which NPSH is used is simple and direct. An assessment is made by the application engineer as to the pressure that will be available at the pump suction flange for the given fluid at design flow rate.

The fluid temperature is also known, and vapor pressure tables define the pressure at which the fluid will boil.

The difference between the available suction flange pressure and the fluid boiling point is then determined and defined as "Available NPSH". Available NPSH is then the available suction flange pressure over and above the fluid boiling point pressure.

What this means is that fluid will not flash or cavitate inside the pump so long as the internal pump pressure drop (Required NPSH) is less than Available NPSH.

As an example, a system under design is intended to pump 212°F water. The application engineer states his conclusion, after calculation that the pump suction flange will be at 12 psig pressure during operation. What is the Available NPSH?

Since 212°F water boils at 0 psig, the Available NPSH must be 12 psi; the pump suction flange pressure will be 12 psi above the fluid boiling point.

Given that the pump internal pressure drop (Required NPSH) is only 8 psi, it will be known that the lowest possible internal pump pressure will still be 4 psi over the boiling point; the pump will not cavitate because Available NPSH is greater than Required NPSH.

Supposing for this example that a pump is inadvertently selected which has a Required NPSH of 14 psi at design flow rate. This condition immediately establishes that the internal pump pressure will be below the boiling point; $12 - 14 = -2$ psi. The internal pump pressure drop (Required NPSH) is greater than Available NPSH; pump cavitation will and must occur.

The example illustrates the fundamental reasoning behind NPSH evaluation procedure. It will be noted, however, that the example has stated NPSH as psi. This has been done only to clarify fundamental usage of the terms. NPSH, whether available or required, is never expressed in psi terms. It is always stated in terms of ft fluid head.

The reason NPSH is stated in terms of ft fluid head is because of the need for generalization. It would not be feasible to publish a different pump capacity curve and NPSH curve for an infinite variety of fluids and, in addition, to provide separate NPSH and capacity curves for all temperature variations with each separate fluid. This would be needed if pump curves and NPSH data were expressed in terms of psi.

Pump curves and NPSH data are illustrated as ft head versus GPM because ft fluid head means differential energy per unit weight of fluid. A pound of water at 85°F weighs as much as a pound of water at 200°F or a pound of gasoline at 60°F. Pump curves and NPSH data expressed as ft head versus GPM is then generalized and the pump data established by water test at 85°F applies without change* to water at 200°F or 45°F, and to gasoline or to a huge variety of fluids within broad temperature and viscosity ranges.

A typical pump curve illustrating capacity and Required NPSH is shown as **Figure 16**.

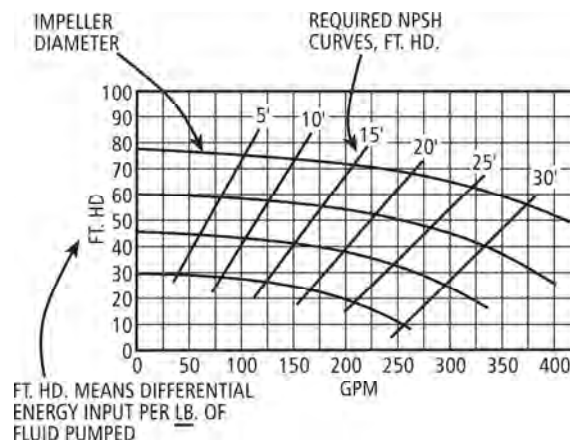

Figure 16. Capacity and NPSH Pump Curve Plot Applies to All Fluids Within Broad Viscosity Range

The need for an ability to apply the developed pump curves to a wide variety of fluids is neatly solved by use of the term ft head. The solution to the one problem causes other difficulties; especially in NPSH application. The difficulty has to do with abstract considerations of the term ft head as classically applied to NPSH evaluations.

NPSH must finally be defined in terms of ft fluid head. Since this is true, the classical methods for application of NPSH data for pump selection is to convert all pressures to ft fluid head, including vapor pressure and atmospheric pressure. It is difficult to picture sea level atmospheric pressure as equivalent to 34 ft of 60°F water head or to 68 ft of fluid at a fluid specific gravity of 0.5. The statements of atmospheric pressure related to ft fluid head are abstract engineering truths, and not concrete, easily visualized truths that can be mentally referenced to gauge pressure readings.



NOTE: Pumping horsepower will change with fluid density.



Cooling Tower Pumping and Piping

Conventional NPSH design evaluations will be avoided in this discussion. This is because of its very abstract nature. Conventional NPSH evaluation can be a very confusing, time consuming procedure for the majority of engineers whose NPSH evaluation needs are generally sporadic.

The B&G NPSH evaluation procedure is as theoretically correct as the conventional. It differs in that the calculation reference is to pump suction flange pressure expressed in terms of psig; gauge pressure - not absolute.

The reference or start point for the evaluation is atmospheric pressure at the pump suction supply level. Simple calculations are then made to determine pump suction flange gauge pressures during operation. An example problem is illustrated in **Figure 17**, for 85°F tower water.

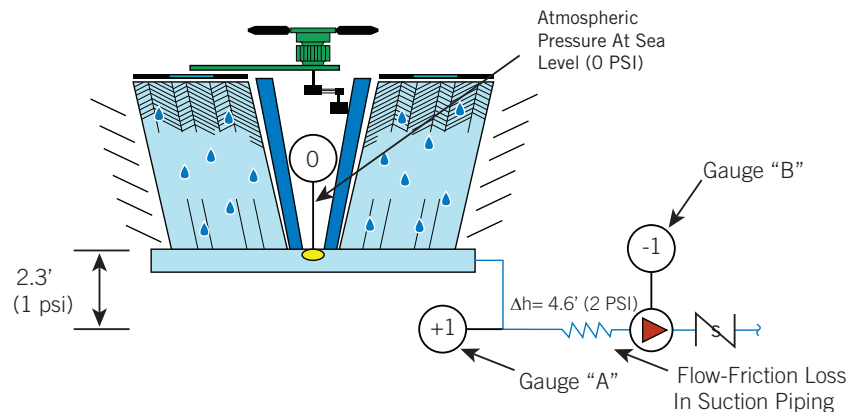

Figure 17. Example Problem

Example Problem

At sea level, the atmospheric pressure pressing on water at the suction pan will be 0 psig.

With tower water at a specific gravity of 1, each 2.3 ft of fluid head = 1 psi.

For these circumstances, and starting with atmospheric pressure at 0 psig, a static fluid head of 2.3 ft would cause +1 psig to be registered at gauge "A." A suction pipe flow-friction loss of 4.6 ft is equivalent to 2 psi pressure drop.

The calculated pump suction gauge pressure reading would then be:

$$\text{Pump Suction} = 0 + 1 - 2 = -1 \text{ psig (Gauge "B")}$$

The B&G NPSH Chart (**Figure 18**) is entered at a calculated pump suction gauge pressure of -1 psig. A line is then run vertically to interception with the fluid vapor pressure; for 85°F water, this is the order of 0.6 psia.

It will be noted that velocity head static pressure reduction ($h = V^2/2g$) has not been taken into account.

Velocity head is a point of concern for the pump manufacturer in his development of Required NPSH. The pump test engineer reads pump suction gauge pressure, converts this to ft fluid head and adds velocity head to obtain pump suction pressure as an absolute fluid energy head statement.

The pump application engineer is not concerned with velocity head in his Available NPSH calculation, however. This is because he is not working with an actual gauge reading. His calculation establishes absolute fluid energy head available at the pump suction only when velocity head is not considered.

Velocity head is only considered for NPSH when an actual gauge reading is used. Velocity head will also be considered when a suction static pressure calculation is made for fluid flash possibility in the suction line; but without NPSH reference.

From this interception point (1) a line is run horizontally to interception with the fluid specific gravity line as at point (2). (In this case specific gravity = 1). Available NPSH is read at point (2); in this case @ 31 ft.

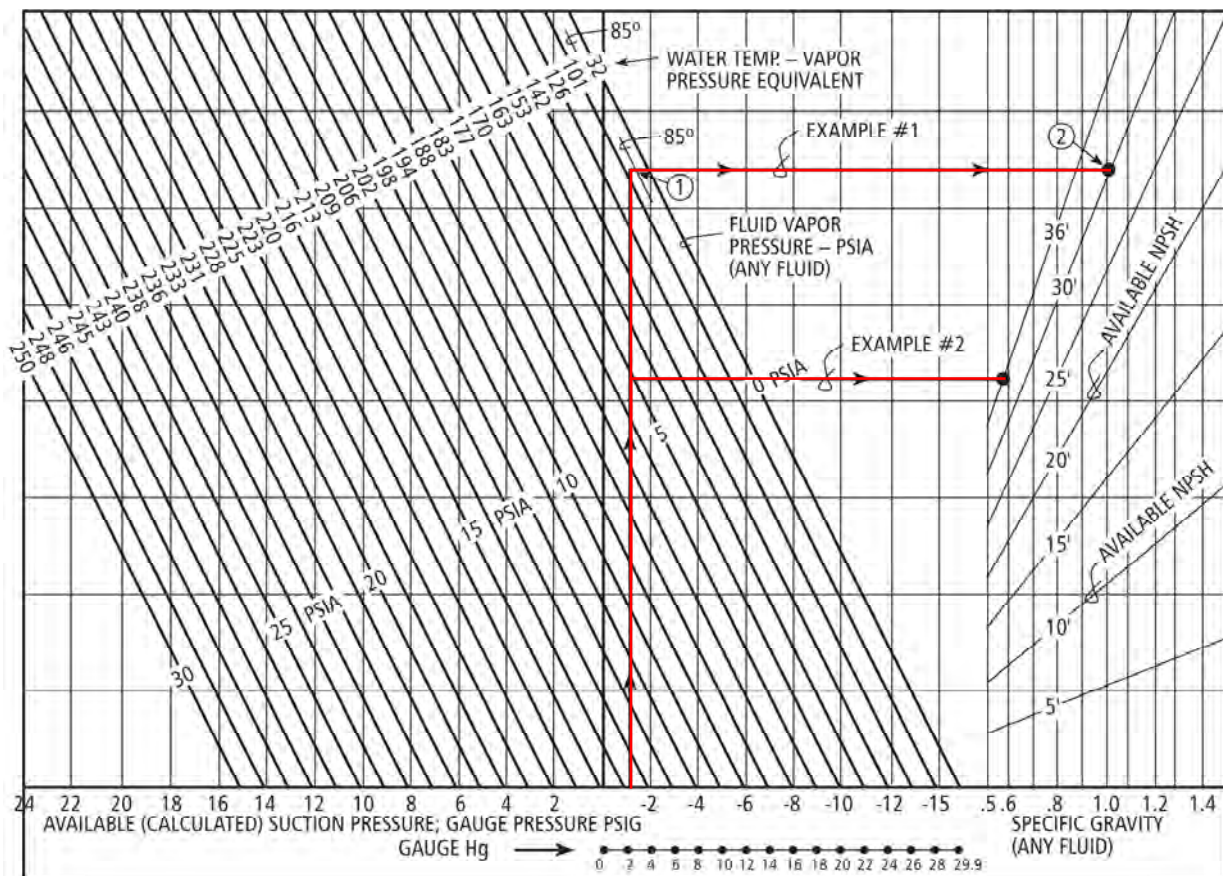

Figure 18



Cooling Tower Pumping and Piping

What has the NPSH Chart accomplished?

The NPSH Chart has simply taken available suction pressure and deducted fluid vapor pressure to establish available pressure over and above the fluid boiling point. This available pressure has then been converted to ft fluid head at the fluid specific gravity. This is fluid pressure-head over and above the fluid boiling point and is defined in conventional pumping terms as Available NPSH.

Our example problem now states that we have 31 ft available NPSH. In order for fluid to flash or cavitate inside the pump, the pump internal pressure drop (Required NPSH) must exceed 31 ft.

To provide a satisfactory pumping system, we need only provide a pump which has a Required NPSH of less than 31 ft.

This will be a simple proposition since only a remarkably bad “end of the curve” pump selection would reach this order of Required NPSH.

The preceding example has important application points as it applies to tower pumping. Before discussing tower pump suction application requirements, however, use of the B&G NPSH Chart for fluids other than water and at elevations above sea level should be pointed out.

When any fluid is to be pumped, the engineer will know its specific gravity and its vapor pressure at the pumping temperature. This data is tabulated in handbooks or is available from the fluid manufacturer.

As an example, an exotic fluid is to be pumped from an open tank in Denver. The fluid manufacturer states that at its pumping temperature, the fluid has a vapor pressure (boiling pressure) of 5 psia and that its specific gravity will be 0.6. Determine Available NPSH for the pumping situation illustrated in **Figure 19**.

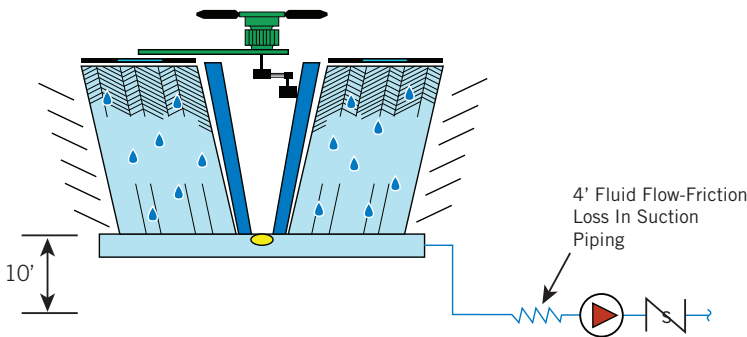

Figure 19. Pumping Diagram; Example Problem

Elevation (ft)	Atmospheric Pressure (psig)
0	0
1,000	-0.5
2,000	-1
3,000	-1.5
4,000	-2
5,000	-2.5
6,000	-3
7,000	-3.5
8,000	-4
9,000	-4.5
10,000	-5

Table 2

It will be useful to tabulate changes in atmospheric pressure with elevation above sea level. It will be noted that atmospheric pressure decreases about 1/2 PSI for every 1,000 ft elevation above sea level.

It will also be useful to tabulate head to psi relationships for various specific gravities.

Fluid Specific Gravity	Ft Fluid Head Equal to 1 PSI
1.5	1.5
1.4	1.64
1.3	1.75
1.2	1.9
1.1	2.1
1.0	2.3 (Usual Water Reference)
0.9	2.6
0.8	2.85
0.7	3.3
0.6	3.85
0.5	4.5

Table 3

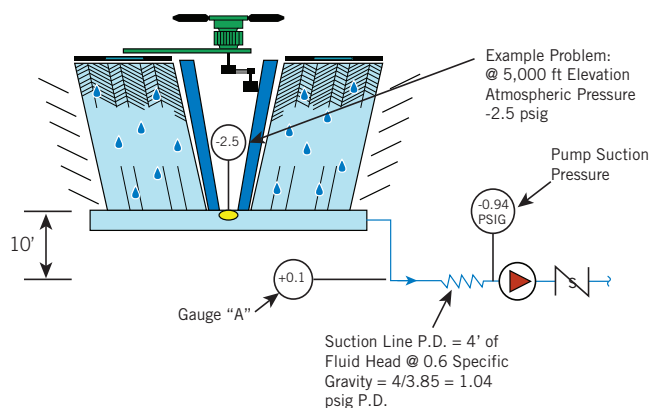

Figure 20. Pump Suction Pressure Example

Suction Pressure Example Problem

The example diagram pump suction pressure would then be established as in **Figure 20**.

In **Figure 20**, atmospheric pressure at -2.5 psig is unaffected by fluid weight. 10 ft of fluid head at 0.6 specific gravity will cause $10/3.85$ or about 2.6 psi pressure. Gauge "A" must then read 2.6 psi over atmospheric pressure or +0.1 psig. The fluid flow-friction loss of 4 ft; $(4/3.85)$ 1.04 psi pressure drop so the pump suction pressure will then read -0.94 psig or the order of -1 psig:

$$\begin{array}{r} \text{(Atmospheric)} \\ \text{Static} \\ -2.5 \end{array} + \begin{array}{r} \text{Friction} \\ \text{Loss} \\ + 2.6 \end{array} - \begin{array}{r} \text{Friction} \\ \text{Loss} \\ - 1.04 \end{array} = \text{-0.94 or about -1 psig}$$

The B&G NPSH Chart is then entered at -1 psig. The next step is to proceed upward to an intersection with 5 psia vapor pressure. A horizontal line drawn from this intersection to a 0.6 specific gravity establishes that the pump will have an available NPSH of 35 ft.

A pump is then selected which has a Required NPSH of less than 35 ft at the design flow rate.

The B&G NPSH Chart is generalized and can be used for analysis of pump suction requirements for any fluid and for any piping system; open or closed. It is not limited to cooling tower application.

It would seem that the previous tower NPSH evaluation points out that very simple application rules will eliminate the need for actual evaluation of NPSH requirements for tower systems.



Cooling Tower Pumping and Piping

> The Tower Pump and Its Suction Line

It is the unusual tower system that has pump suction troubles. This is because of inherent safety factors. Trouble can be experienced, however, when relatively simple application rules are not followed.

The first pump suction application rule is:

Leave the Suction Line Alone!

So long as the suction line is only pipe and the pump is below the tower pan water level, the available NPSH will be at least to the order of 30 ft. Any pump selected to a reasonable point on its curve will work.

High pressure drop units in the pump suction line are generally installed by the amateur in the “wreck it yourself” approach.

Tower bypass valve, checks, balance valves, and fine mesh strainers can almost always be installed in the pump discharge - and should be.

If it becomes absolutely necessary to install a strainer or check in the suction line, a strong specification should be stated with respect to minimizing allowable pressure drops.

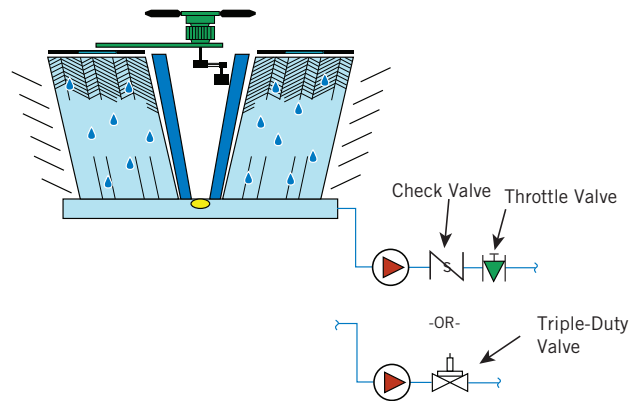

Figure 21. Leave Suction Line Alone - **RIGHT**

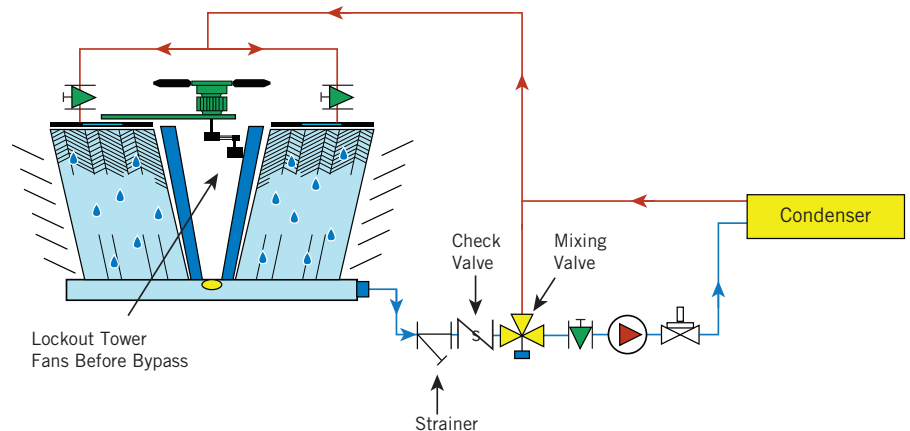

Figure 22. High Pressure Drop Strainer, Check, Control, and Balance Valve in Suction Line - **WRONG**

The second application rule is:

Place the Pump Below Tower Pan Water Level!

In **Figure 23**, the pan water level is shown above the pump for the illustration. This insures a flooded pump on start-up. It is best to maximize “H”, if possible, even a minimum “H” of the order of several feet static height will still provide a very high Available NPSH (generally above 30 ft) provided the suction line is left alone, and does not exceed the order of 5 ft friction-flow loss.

In **Figure 24**, the pump will not be flooded on start-up and will, therefore, require the fill as illustrated. A check valve must be provided in the suction line to prevent suction line drainage.

Available NPSH has now been reduced because the pump is above pan water level and because a suction line check or foot valve has become necessary.

The diagramed situation can usually be avoided. If unavoidable, however, a careful NPSH evaluation should be made and strong specifications made concerning allowable check valve pressure drop.

A third suction line application point is:

Avoid “Above the Pump” Air Traps in the Suction Line!

Installations as in **Figure 25** should, and usually can be avoided. When absolutely unavoidable, the modifications shown in **Figure 26** will prove of help.

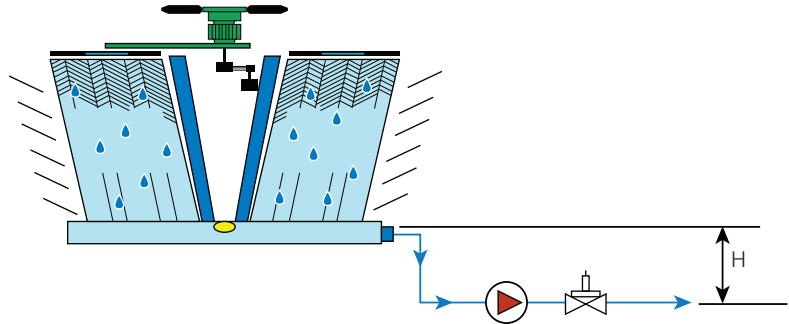

Figure 23. Pump Below Pan Water Level - RIGHT

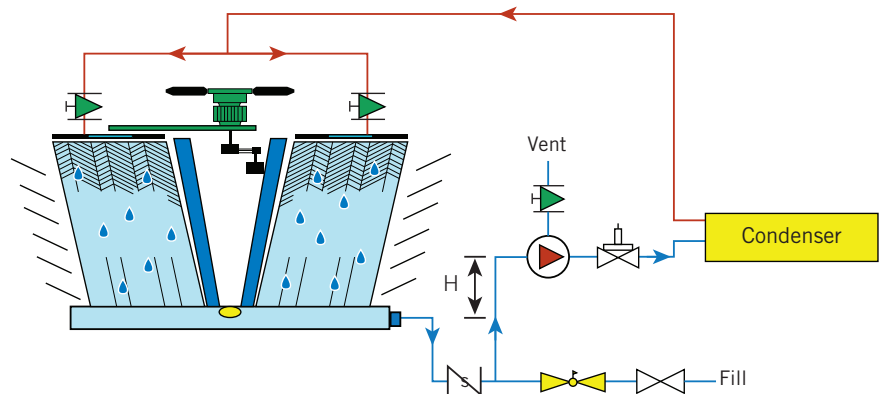

Figure 24. Pump Above Pan Water Level - Avoid if Possible

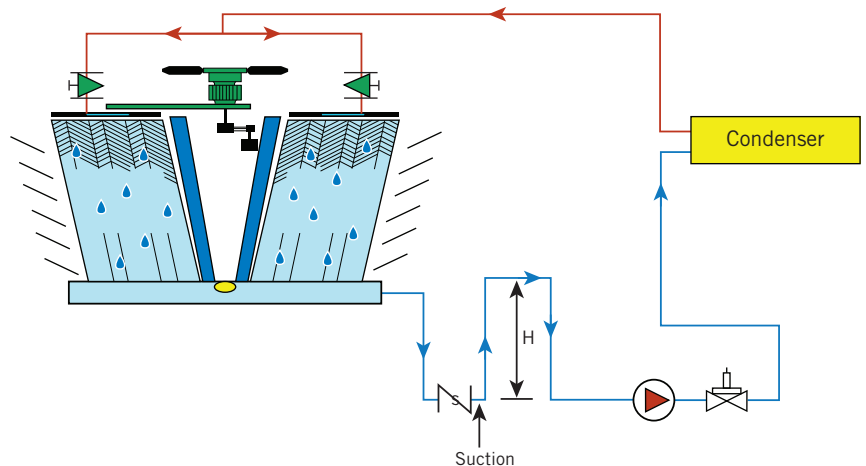

Figure 25. Suction Line Air Trapped - WRONG



Cooling Tower Pumping and Piping

While the air trapped suction is still not recommended, the modifications illustrated in **Figure 26** will help alleviate the otherwise intolerable operating conditions established in **Figure 25**.

Careful evaluations as to available pump suction pressures will have to be made and strong specifications stated to allowable check valve pressure drop.

A fourth suction line application point concerns:

Avoid Fine Mesh High Pressure Drop Strainers in the Suction Line!

Pump suction line strainers are apparently one of those peculiar “be darned if you do and darned if you don’t” propositions. There are two conflicting needs.

1. Protection of the system; pumps, valves, condenser, spray nozzles, etc. against dirt and debris.
2. The fact of placing a fine mesh strainer in the suction piping will make a mockery of the most careful pump suction pressure evaluation. This is because an uncontrollable variable has been introduced; once the strainer gets clogged cavitation will occur.

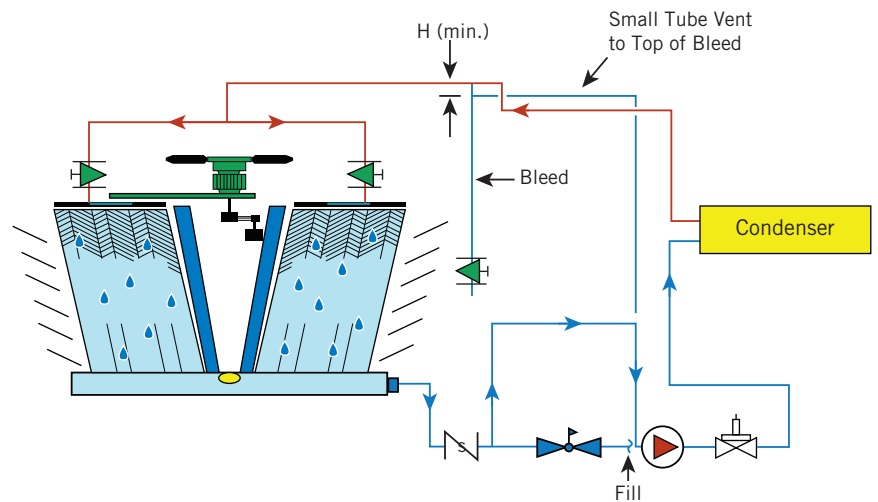

Figure 26. Improved Suction Line Air Trap Installation

The problem is not unsolvable, however, once it is understood that the centrifugal pump will pass fairly large objects. This means that strainer mesh openings from 3/16” to 1/4” can be used if the only function of the strainer is to protect the pump.

Tower pans are usually provided with an exit strainer (at tower outlet to suction piping) of this mesh order. Such tower strainers should be specified since they can be watched and are easily cleaned without piping drainage.

When tower pan strainers cannot be provided, a large mesh low pressure drop strainer can be placed in the suction line. Such strainers should be strongly specified both as to mesh size (3/16” min.) and pressure drop.

Fine mesh strainers are often needed for protection of the condenser, its valves, and/or spray nozzles. The fine mesh strainer should be placed at the pump discharge; usually between pump discharge and the pump check valve. This location will often simplify the work of the operator in removal and cleaning of the easily clogged basket.

Figure 27. Fine Mesh Strainer in Pump Suction Line - **WRONG**

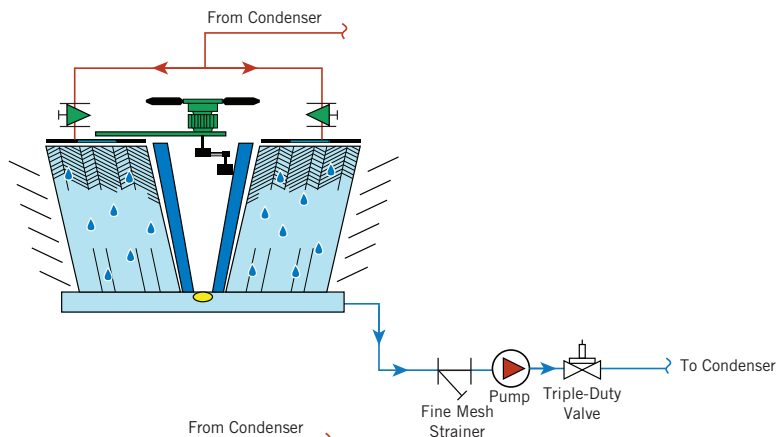

Figure 28. Tower Strainer Protects Pump; Fine Mesh Protects Condenser, Etc. - **RIGHT**

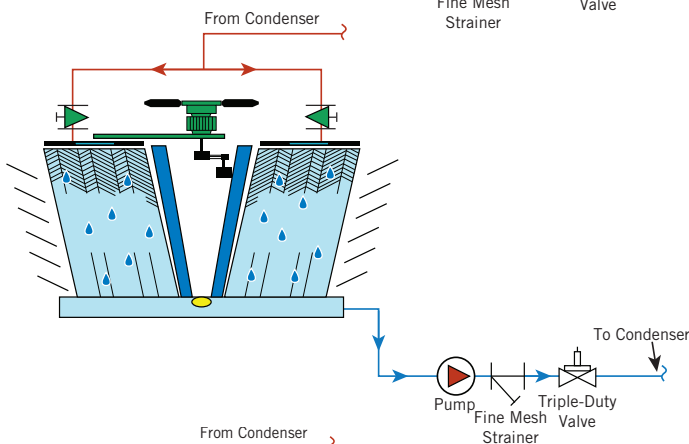
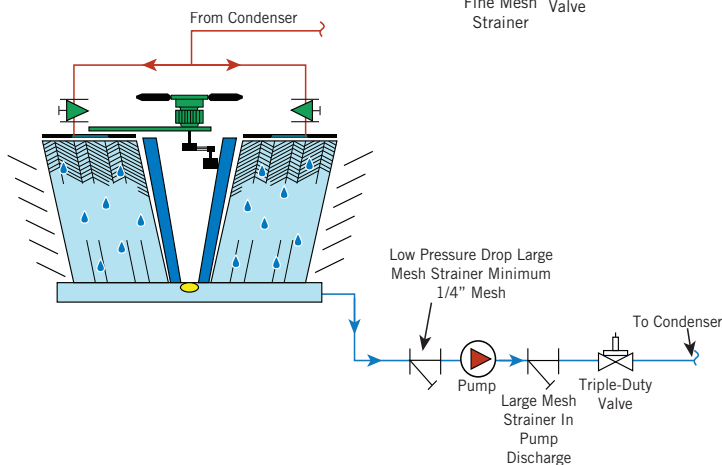

Figure 29. Large Mesh Strainer Protects Pump; Fine Mesh Protects Condenser, Etc. - **RIGHT**



Cooling Tower Pumping and Piping

Strainer clog always has and will continue to present operating problems; old newspapers, cottonwood seeds, tree leaves, etc. seem to find their way with an unerring directional sense to the tower - and ultimately to the tower strainers.

Several protective measures are available; the tower itself can be screened and a tower overflow can be used (in place of bleed blow-down) to “float off” leaves and other debris to drain before they get into the piping strainers.

The importance of a well designed tower pan strainer and proper maintenance should again be emphasized.

Given even the best preventative measures, strainers will still become clogged, however, and the operator should be given simple working tools to determine when strainers need cleaning.

A differential gauge can be placed across the strainer. This can often be set to trigger an alarm under high pressure differential (clogged strainer) conditions. This is illustrated in **Figure 30**, together with a manual differential read-out method.

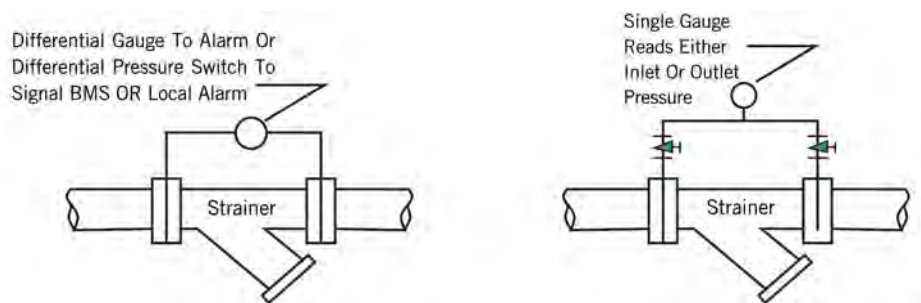

Figure 30. Reading Strainer Pressure Differential

> Predicting Pump Operating Points

The System Curve

Actual pump operating points considerably beyond that stated in the pump specification should be guarded against. The more than predicted flow rates can cause tower air vortexing and will increase pump cavitation probability. Increases in system flow rate will decrease available pump suction pressure and, at the same time, state a need for increased suction pressures.

System curve analysis will be used to point out the importance of the initial specification points; the importance of balance or throttle valves and the importance of stable operating points. This is because system operating characteristics may be affected by tower bypass control and other factors.

The closed loop system curve analysis considers only flow-friction loss. Static head losses do not occur in the closed loop piping circuit.

A closed loop piping circuit is illustrated in **Figure 31**. The flow-friction or energy head loss is calculated at 40 ft at a flow rate of 300 GPM.

It should be apparent, for **Figure 31**, that if only 150 GPM flow rate occurred, the flow-friction loss will be less. This is so, and the change in energy head required to drive 150 GPM, rather than 300 GPM, through the piping circuit is defined by the basic flow-friction loss relationship which states:

“Friction loss changes as the square of the flow change.”

In other words, a reduction of flow to one half that initially stated means a friction or head loss reduction to $(1/2)^2$ or $1/4$ that required for the conditions. If we reduce flow to 150 GPM, from 300 GPM, the friction loss for **Figure 31** will only be 10 ft:

$$(40 \times (1/2)^2 = 40 \times 1/4 = 10 \text{ ft}).$$

This relationship can be set up on a programmable calculator, computer, or the B&G System Syzer, available at www.bellgossett.com.

Considered in isolation, the changes in system friction loss can be stated as Ft Head versus GPM in the tables as below.

Flow (GPM)	0	50	100	150	200	250	300	350	400
Ft Head	0	1.1	4.4	10	17.8	27.8	40	54.4	71.1

Table 4

The above numbers can also be calculated with the following equation: $H_2 = H_1 * (Q_2/Q_1)^2$

Where:

- H_2 = Future Head Pressure
- H_1 = Known Head Pressure
- Q_2 = Future Flow (gpm)
- Q_1 = Known Flow (gpm)

Flow	Head (H_2)	Equation
0	0	$= 40 * (0/300)^2$
50	1.1	$= 40 * (50/300)^2$
100	4.4	$= 40 * (100/300)^2$
150	10	$= 40 * (150/300)^2$
200	17.8	$= 40 * (200/300)^2$
250	27.8	$= 40 * (250/300)^2$
300	40	$= 40 * (300/300)^2$
350	54.4	$= 40 * (350/300)^2$
400	71.1	$= 40 * (400/300)^2$

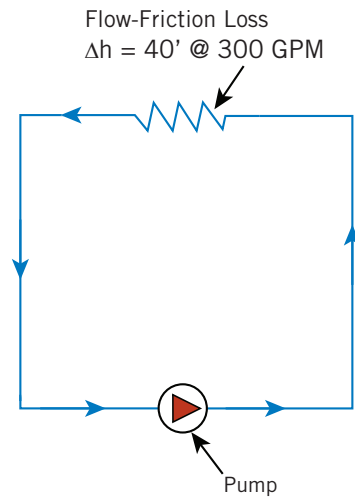

Figure 31. Flow Friction Loss in Closed Piping Circuit Determines Required Pump Head; Height Not Considered



Cooling Tower Pumping and Piping

The previous numbers in **Table 4** can be plotted on a Ft Head versus GPM chart as in **Figure 32** and will illustrate the piping circuit flow-friction loss or head relationship for the closed loop piping circuit shown in **Figure 31**.

The First Law of Thermodynamics expressly establishes that:

“ENERGY IN = ENERGY OUT.”

It must then follow the plotting of a pump curve across the system curve establishes the point of operation for that particular pump when applied to the particular piping system stated for **Figure 31**. The pumping point must be at the intersection of the pump curve with the system curve; as illustrated in **Figures 32** and **33**. It is recommended to plot this data on the actual pump curve as indicated.

A great many application observations could be made concerning closed loop pumping as shown in **Figure 31**. Our present concern, however, is not with the closed loop but is with the open loop, in particular the tower piping circuit. The difference is that we must take into account the “open” or “static” pumping head.

Supposing now, that we establish the same flow-friction loss; 40 ft at 300 GPM, as for our previous example - but state this to a tower pumping example with a “static” or “open circuit” pumping head requirement of 13 ft.

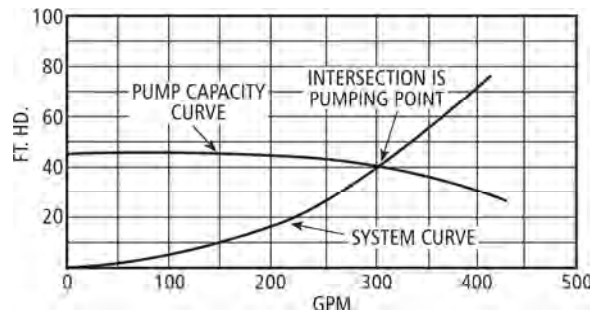

Figure 32. Plot of Flow-Friction Loss or System Curve for Figure 31

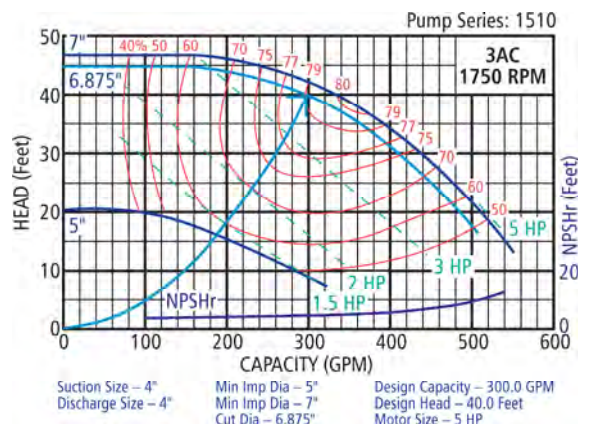

Figure 33. Intersection of System Curve with Pump Curve as Pumping Point

Reference should be made to previous discussion concerning determination of “open” piping circuit pump head requirements (Pages J120 - J127).

Given, however, that the flow-friction loss is 40 ft at 300 GPM, we would set up a table exactly as **Table 5** for the closed piping circuit analysis. This would describe the flow-friction loss relationship in the piping circuit shown in **Figure 34**.

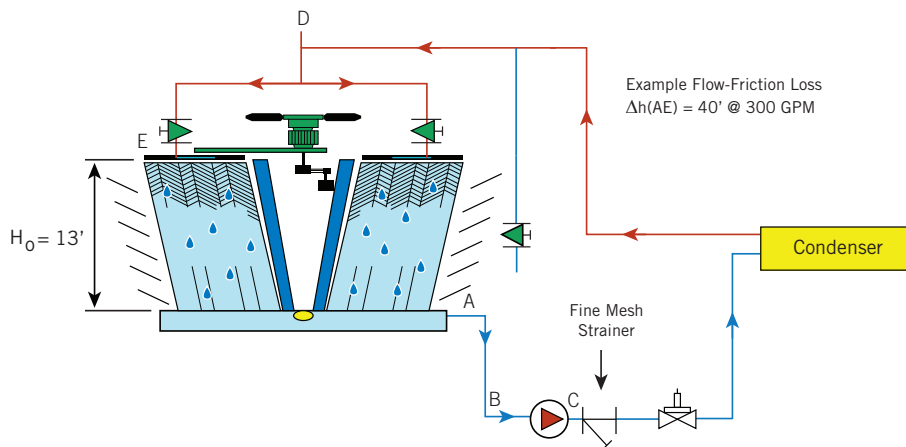

Figure 34. Tower Example; $\Delta h (AE) = 40'$ $H_0 = 13'$

Flow (GPM)	0	50	100	150	200	250	300	350	400
Ft Head	0	1.1	4.4	10	17.8	27.8	40	54.4	71.1

Table 5

It will be apparent, from **Figure 34**, that water flow cannot occur, until the pump has raised water from level “A” to level “E”; a height of 13 ft.

The open pipe circuit system curve differs from “closed loop” in that static head loss must be introduced into the problem.

Static head losses are added to the flow-friction losses to establish total head requirement at various flow rates. This is illustrated in **Table 6** for **Figure 34**.

Flow (GPM)	0	50	100	150	200	250	300	350	400
Friction Loss (Ft Head)	0	1.1	4.4	10	17.8	27.8	40	54.4	71.1
Static Head (Ft Head)	13	13	13	13	13	13	13	13	13
Total Head Loss (Ft Head)	13	14.1	17.4	23	30.8	40.8	53	67.4	84.1

Table 6

Plotting of total head loss versus GPM establishes then, the “open system curve” for the piping circuit defined in **Figure 34**. The pump curve intersection with the system curve so described illustrates the actual pumping point. This is again defined by the First Law.





Cooling Tower Pumping and Piping

System curve analysis will be of value in evaluating:

1. Pump operating point shift due to less than anticipated flow-friction loss in the piping circuit.
2. Unstable pump operation as caused by:
 - a. Incorrect tower bypass arrangements.
 - b. Tower bypass with high pressure drop spray nozzles.

Pump operating points should be stable and as close to that specified as possible in order to set up design safeguards against tower vortexing and pump suction problems.

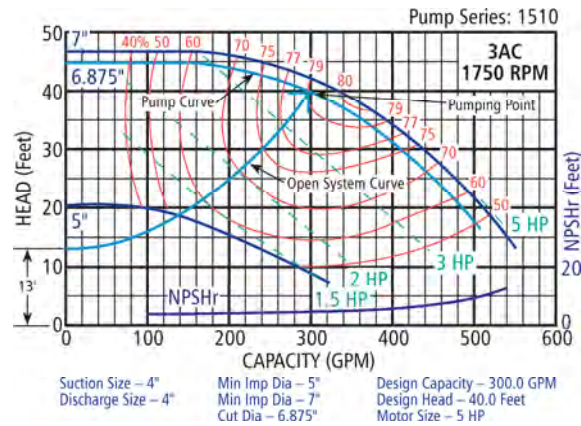

Figure 35. Open System Pumping Point

Non Bypassed Tower Pump Operating Shift

While tower pump static heads can be easily defined, the flow-friction heads will often be less determinate.

Installed condenser pressure drop may be less than specified and the pipe friction loss less than anticipated.

The piping friction loss is often based on a pipe “age” factor, based on possible interior pipe fouling due to aerated tower water. The rate of fouling is a relative unknown, leading to divergent engineering practice.

1. Some engineers design to clean pipe; Hydraulic Institute or B&G System Syzer. The opinion being that the tower must be treated in order to insure condenser performance and that chemical treatment will provide against the pipe fouling problem.
2. Others engineers provide an “age” factor for pipe pressure drop ranging from 50% over “clean” data to 100% or twice that used for the closed loop system. Pipe pressure drop data for “15 year old” pipe is stated to the order of twice that used for clean pipe.*



NOTE: The B&G System Syzer can be used for either clean or “aged” conditions. When used for “15 year old” pipe, the illustrated friction loss is simply multiplied by 2.

Unlike the closed loop heat-cool Hydronic System, it does not generally make a great deal of difference as to whether “clean” or “15 year old” pipe friction loss data is used for the tower system. This is because pipe friction loss is usually only a small part of the total pump head; system statics and the condenser providing the major part.

As an illustrative example, a proposed tower system is composed of the following elements concerning pump head.

Static or Open “Head”	12’
Condenser	25’
Valves, Strainer, etc.	7’
100’ Piping @ 15 Year Old	6’
<hr/>	
TOTAL HEAD	50’

The actual clean pipe pressure drop is only 3 ft, so that the true initial head is 47 ft rather than 50 ft. The difference (system curve not shown) would cause an increase in flow rate of some 4%; an insignificant change.

Much more significant and bothersome change can be caused by substitution of a low pressure drop condenser when the pump head estimate is based on the highest pressure drop condenser unit expected to be bid.

The same tower system will be evaluated; estimated head will be compared with actual head loss.

	Estimated Head Loss	Actual Head Loss
Condenser	25’	8’
Valves, Strainer, etc.	7’	7’
150’ Piping @ 15 Year Old	6’	3’
<hr/>		
Total Flow-Friction	38’	18’
Static or Open	+ 12’	+ 12’
<hr/>		
TOTAL PUMP HEAD	50’	30’

Table 7





Cooling Tower Pumping and Piping

The pump is specified at design flow for 50 ft while the true head loss is only 30 ft. Assuming a design flow rate of 300 GPM, what will the actual flow be?

A system curve table plot is made following procedures previously provided.

Flow (GPM)	0	250	300	350	400	450
Actual Flow-Friction (Ft Head)	0	12.5	18	24.5	32	41
Static Head (Ft Head)	12	12	12	12	12	12
Total Head Loss (Ft Head)	12	24.5	30	36.5	44	53

Table 8

The system curve plot is then as illustrated as **Figure 36**.

The pump point shift has increased flow over design to the order of 45%. Cavitation and/or tower vortex can occur unless corrective measures are applied.

The pump impeller diameter could and should be cut down to match the pump to the system.

It is more usual, however, to simply throttle the pump discharge. This leads to a very important tower application point:

THROTTLE OR BALANCE VALVES SHOULD NOT ONLY BE INSTALLED AT THE PUMP DISCHARGE; THEY SHOULD BE USED!

When the balance valve is significantly closed, trim the impeller and open up the balance valve.

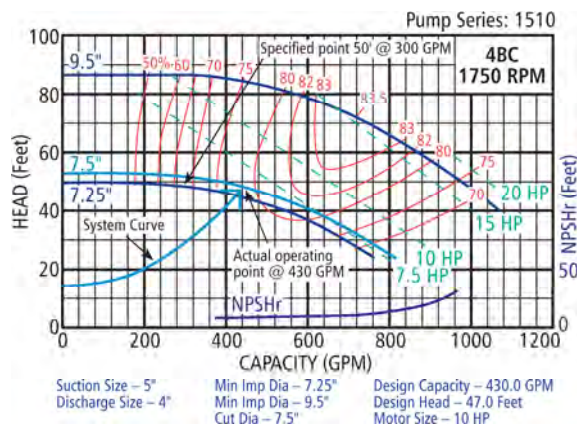

Figure 36. Example System Curve; Less Than Anticipated Pump Head

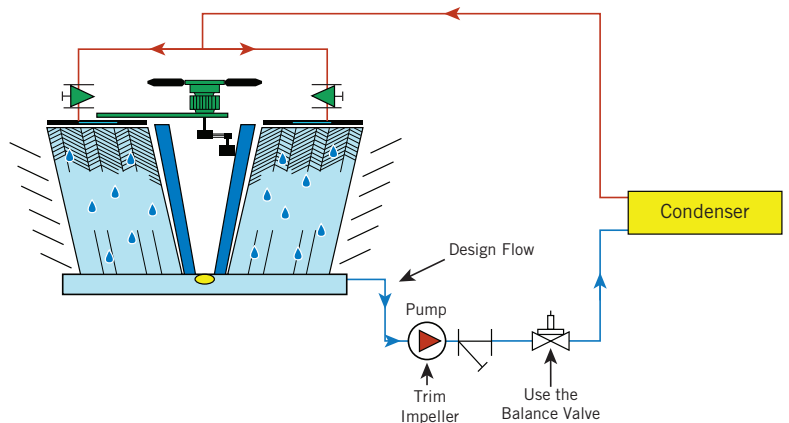

Figure 37. Use of the Balance Valve Will Often Prevent Air Vortex and Suction Pressure Problems

Flow through the tower system can be measured by any of several methods:

1. Pump differential pressure (based on pump curve).
2. Condenser differential pressure (based on manufacturer's data).
3. Triple-Duty Valve (combination check and throttle) differential pressure (based on calibrated C_v data for various valve openings).

Given a stable pumping arrangement, a properly set balance valve will help protect the pump against many operating problems.

The unstable tower pumping system will be aided by use of the balance valve - but problems may still occur because of improper tower bypass applications.

> Tower Bypass

Tower Bypass - General Methods

Improperly applied tower bypass control arrangements can cause unstable pump operation and large volume flow changes through the condenser. Condenser flow change can cause chilled water temperature control instability, especially for absorption machines, and will greatly increase pump trouble probability.

There are two basic methods for tower bypass:

1. Bypass to tower pan.
2. Bypass to suction piping.

Bypass to the tower pan will generally be preferred because of greater flow stability and because the possibility of air suction into the pump is greatly reduced.

Bypass control valves that are used are:

1. Three-way "diverting or bypass."
2. Two "linked" two-way valves (usually butterfly valves) acting as a three-way diverting valve.
3. A single two-way butterfly valve placed in the bypass line.

It should be particularly noted that three-way mix valves should not be applied to tower bypass control.

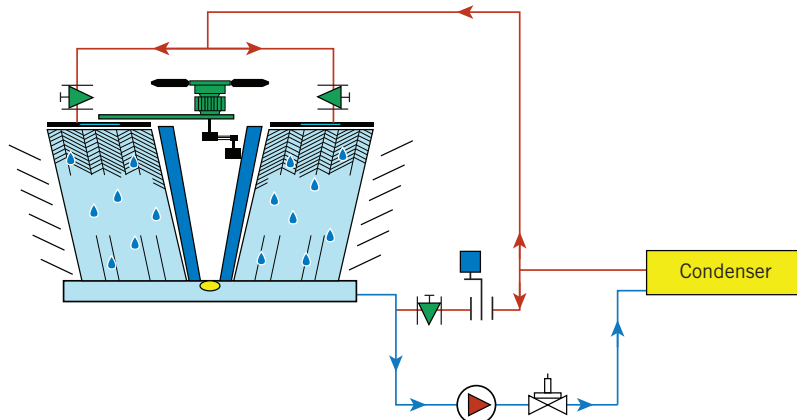

Figure 38A. Basic Tower Bypass Methods - to Suction - Not Recommended

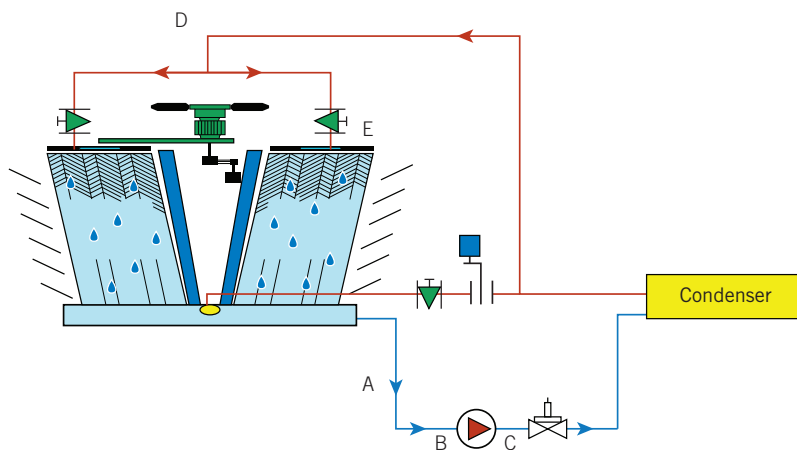

Figure 38B. Basic Tower Bypass Methods - to Basin - Recommended



Cooling Tower Pumping and Piping

The three-way mix valve (two inlets; one outlet) should not be used for tower bypass application because it must be placed in the pump suction line and can cause pump suction pressure problems. The three-way mix valve application is “inviting” in the sense that the mix valve costs less and is more readily available than the diverting three-way valve. Its actual application is only an invitation to trouble, however.

Three-way diverting (one inlet; two outlets) application is much preferred since this valve will be placed in the condenser return line (pump discharge) where its operation will not effect pump suction pressures.

Relatively high cost and limited availability generally confines use of the actual three-way diverting valve to sizes in the general order of 4” or less.

For pipe sizes beyond the order of 4” or larger, linked butterfly valves are usually provided to serve the same function.

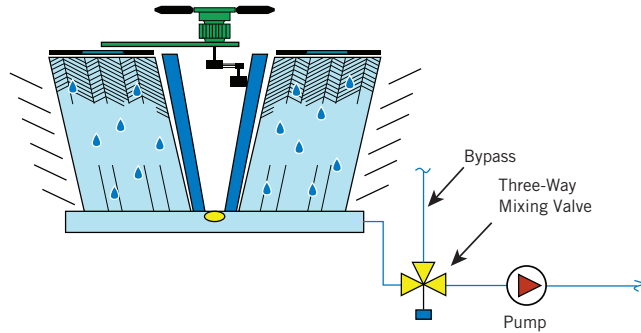

Figure 39. Three-Way “Mix” - Do Not Use

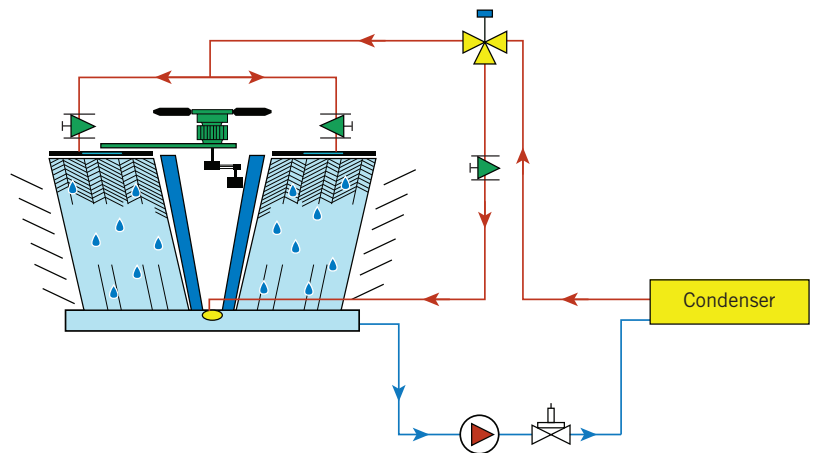

Figure 40A. Use Diverting Valves Not Three-Way Mix

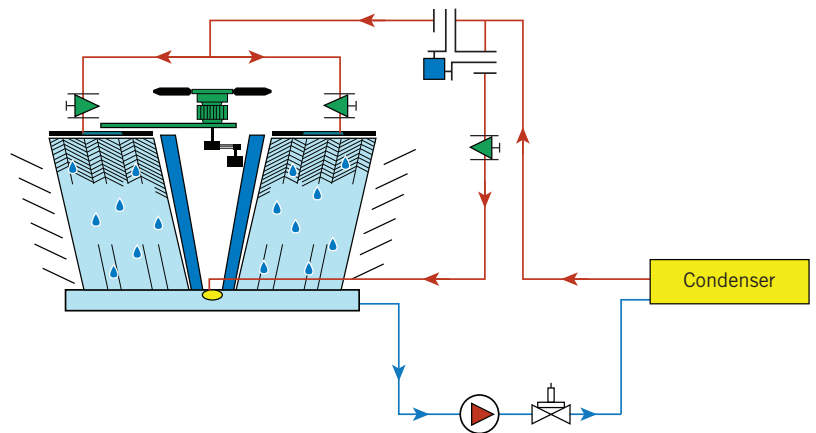

Figure 40B. Use Diverting Valves Not Three-Way Mix

The single two-way butterfly valve is also used for tower bypass; two generalized application possibilities are shown with the valve installed in the bypass line.

Basic conceptual patterns and valve bypass arrangement possibilities have been presented. The problem now is to establish application considerations that will eliminate pump instability when bypass actually occurs. Three working tools are needed:

1. Tower circuit pump head requirements; static and flow-friction. These considerations have already been presented (covered in pages J120 - J122).
2. Tower system curve analysis methods. This has been illustrated (covered in pages J146 - J148).
3. Knowledge of valve operational patterns; flow-friction loss as related to size and valve opening. This has not been shown (covered in pages J140 - J144).

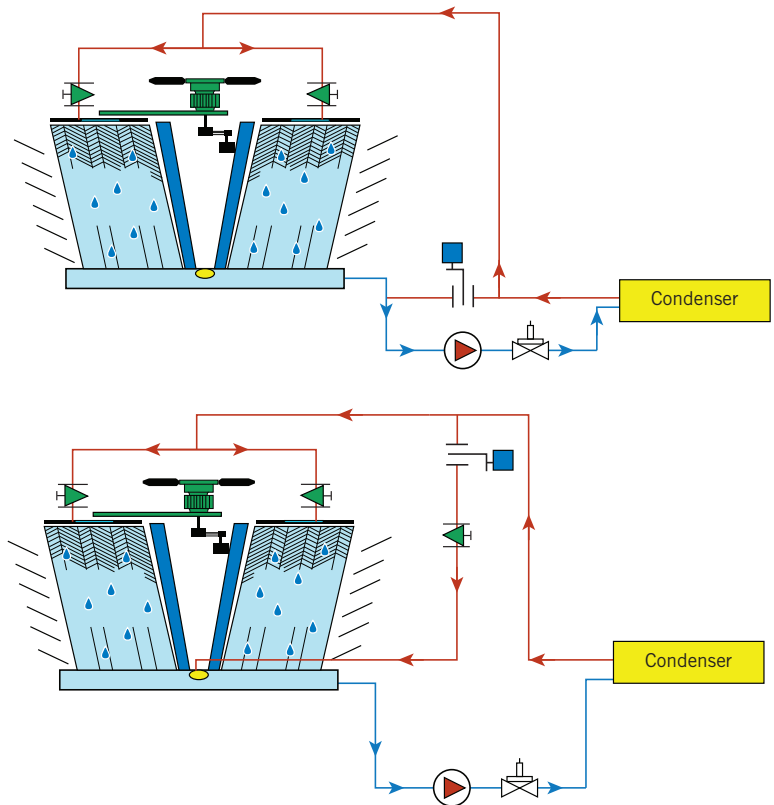

Figure 41. Single Butterfly Also Used for Bypass

Bypass Valve Operational Characteristics; Valve Coefficient (C_v)

Valve " C_v " is a statement of the flow rate necessary to cause a pressure drop of 1 PSI across the valve.

While the pressure drop at C_v flow rate is conventionally defined as 1 PSI, it is better for general system application to consider this in terms of ft fluid head equivalent. For Hydronic System work then:

C_v = GPM Flow Rate at 2.3 ft Head Friction Loss Across the Valve

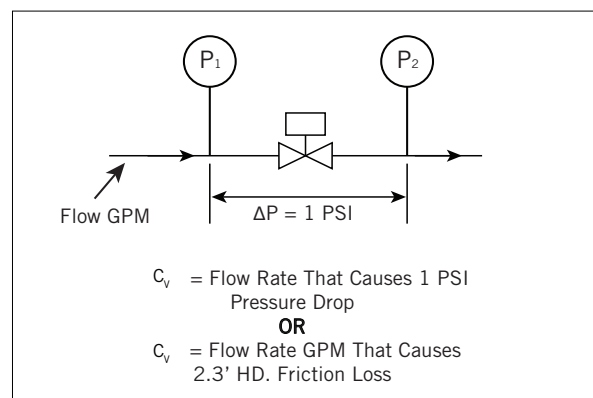

Figure 42. C_v Relationship





Cooling Tower Pumping and Piping

As with the system curve previously described, a change in flow rate will cause a change in head loss. Head loss will change as a squared function of flow rate. The tabulated change can be plotted as in **Table 9** for a valve; $C_v = 10$.

Flow (GPM)	0	5	10	15	20	25	30	35	40
Ft Head	0	0.6	2.3	5.2	9.2	14.4	20.8	28.3	37.0

Table 9

The points shown in **Table 9** can be plotted on a Ft Head versus GPM chart to illustrate the complete flow-friction loss relationship defined by the specific $C_v = 10$.

The curve illustrates that at a flow rate of 20 GPM a pressure drop of 9.2 ft will occur through a valve rated at $10 C_v$. Curve plots are generally not necessary, since the B&G System Syzer will provide this same information in a single simple setting.

As an example in use of C_v , a valve is to be installed for bypass, and application considerations require that a 20 ft head be developed across the valve at 300 GPM design flow rate.

From the B&G System Syzer: 20 ft at 300 GPM = C_v of 102.

A valve selection for $C_v = 102$ will meet requirements.

Valve C_v information is provided by control valve manufacturers in either tabulated or chart form.

Figure 43 shows a possible plot of C_v for a line of butterfly valves, 2" to 12" in size. This plot illustrates changes in valve C_v from wide open (90°) through various degrees of closure. It should be understood that this plot simply illustrates the general order of C_v relationship for butterflies and should not be used for actual design.

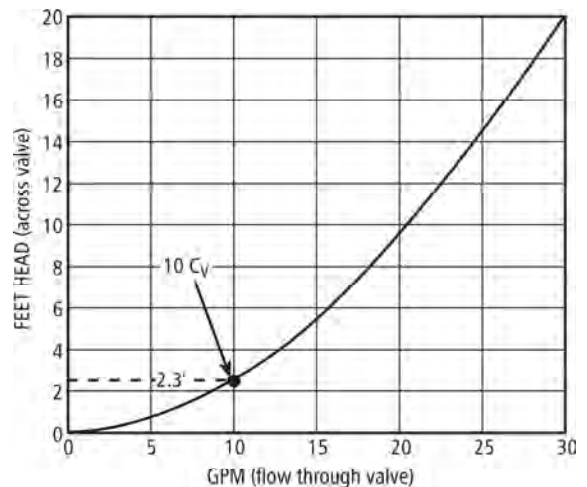

Figure 43. Valve Flow-Friction Loss Relationship Described By $C_v = 10$

For a C_v selection of 102, the following valve sizes can be used:

Valve Size	$C_v = 102$ @ Approximate Degree Open
5"	34°
4"	42°
3"	53°
2.5"	68°

Table 10

Actual valve selection would be left to control people. It is of interest to note, however, that 300 GPM dictates a pipe size of 5" while valve selection possibilities range down to the order of 2-1/2" with an increased control "range" (degree movement) for the smaller valve. This will usually mean more control precision.

It should be noted that for two-way modulating valves, C_v changes as the valve moves from open to closed. This is not true for a conventional three-way valve applied to modulating service.

Three-way valves are designed to a comparatively constant C_v factor. That is to say; at a constant differential head, a constant total flow will occur through the valve; whether through a single port or through any combination of port openings.

Directly linked butterfly valves acting as a three-way will not necessarily establish this same correlation, however. This will be seen from examination of **Figure 44**.

A 3 inch valve at $C_v = 120$ will be set for the order of 60° open. This would be the setting for both the tower valve and its linked bypass valve when either is open with the other closed.

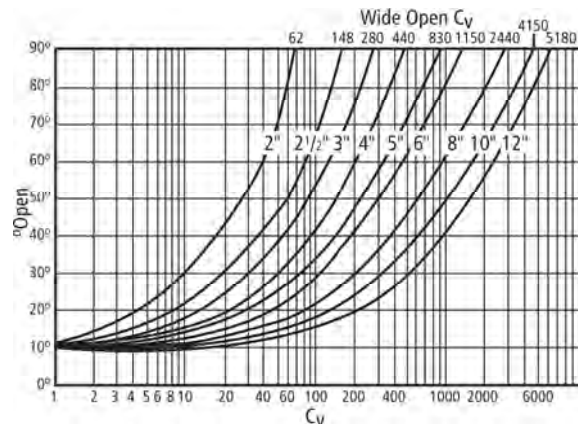

Figure 44. Approximate Butterfly C_v As Related to - Open

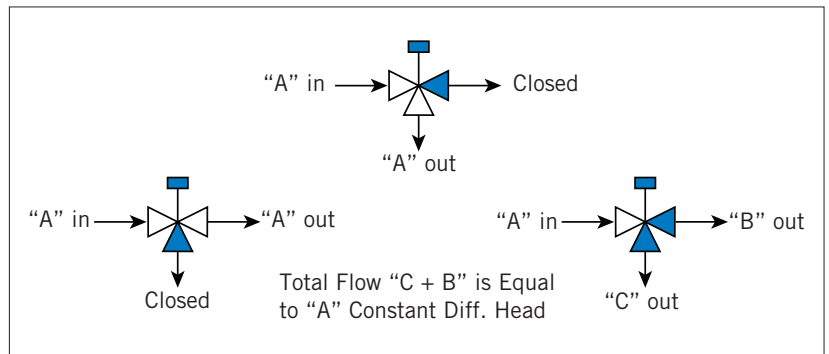

Figure 45. Three-Way Valves are Designed to Constant C_v



Cooling Tower Pumping and Piping

At 50% position, each valve is positioned at 30° and the direct link would state that each valve would have a C_v to the order of 30; with a total “linked” C_v of 60.

This means, unless precautions are taken, that the linked valves will provide a rising pressure drop characteristic on bypass. For the example; pressure drop at a 50% open condition for both valves would be the order of four times that when one valve is open and the other closed.

In terms of tower bypass control, the above means that condenser flow can be reduced when bypass occurs. The precautions taken are:

1. Use of three-way diverting valves when size availability and cost permits.
2. When “linked” butterfly valves are applied, generally in sizes 4” and above, the valves should be selected for low pressure drop characteristics at design flow. This will minimize condenser flow reduction on bypass.
3. Knowledgeable control people will often avoid a single operator with directly linked butterfly valves. They often prefer individual valve operators with “lead-lag” operation to reduce C_v change on bypass.

It should be noted that the peculiar characteristic of butterfly valves is sometimes of benefit.

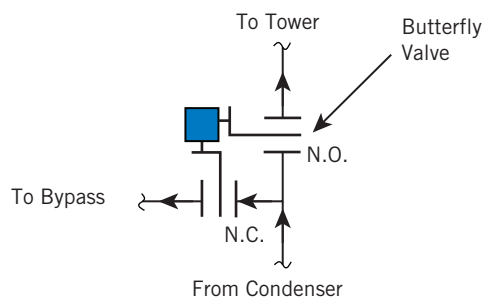

Figure 46. Directly Linked Butterflies can Reduce Condenser Flow when in Partial Bypass and when Valves are Selected to High P.D.

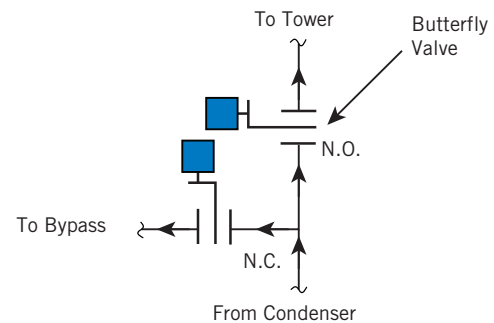

Figure 47. Individual Operators in Lead-Lag Sequence Helps Solve Problem as Does P.D. Selection

Tower Bypass; Design for Flow Stability

Working tools have now been provided for analysis of various tower bypass arrangements as they affect pumping stability. It will again be noted that pumping instability can affect chilled water temperature control and greatly increases pump trouble potential.

Bypass to Pump Suction; Bypass and Condenser Below Tower; Tower with Splash Basin

A proposed floor below condenser installation is shown in **Figure 48**. Bypass is to the pump suction and it will be noted that the usual check valve in the tower suction line (AB_1) has been omitted for discussion reasons.

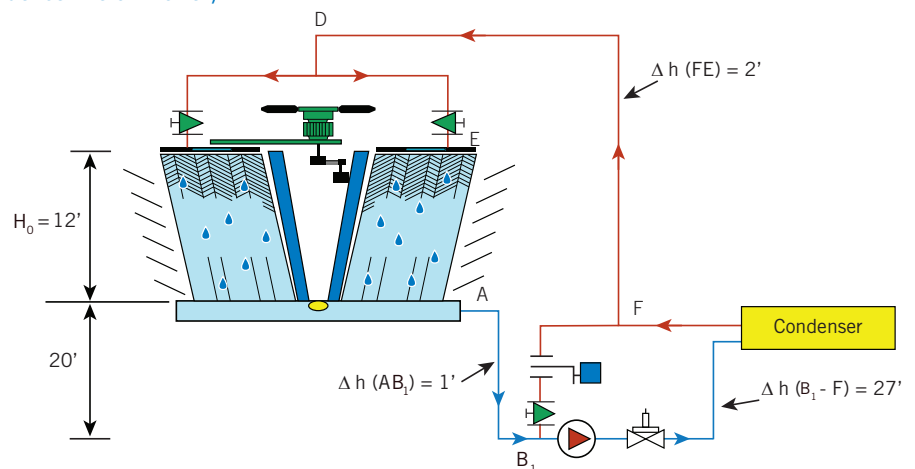

Figure 48. Tower Bypass Example

$$\begin{aligned}
 \text{PUMP HEAD SELECTION} &= H_0 + \Delta h(AB_1) + \Delta h(B_1F) + \Delta h(FE) \\
 &= 12 + 1 + 27 + 2 \\
 &= 42 \text{ ft}
 \end{aligned}$$

Assume now that the bypass valve is 5" butterfly (selected at line size for 300 GPM) and has not yet been "set" by the control contractor; the valve swings to wide open at $C_v = 830$ (See **Figure 44** on **page J155**).

At 830 C_v and at 300 GPM, the bypass valve would develop only 0.3 ft head resistance and because of this, trouble could develop.

It will be noted for this example, and for all tower bypass to the pump suction, that complete bypass will cause the following changes to occur:

1. Tower suction line friction loss will be eliminated because of no flow.
2. Tower discharge line friction loss will be eliminated.
3. Static head will be lost.



Cooling Tower Pumping and Piping

Pump static head will be lost if bypass valve back-pressure to point "F" is insufficient to maintain a full column of water in the tower line. For our example the levels would change as illustrated in the following diagrams in which gauge readings are stated in Ft Head.

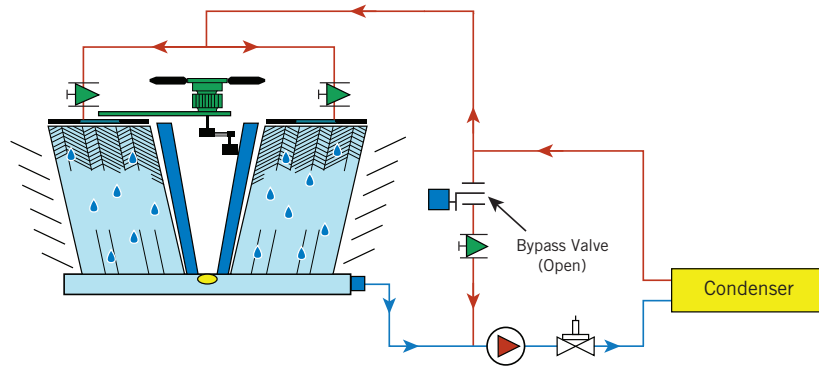

Figure 48A. Pump Off (For Figure 48 on Page J157)

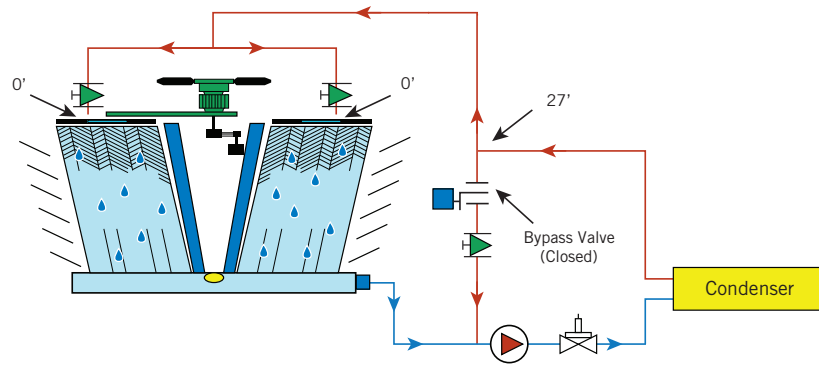

Figure 48B. Pump On; Bypass Closed (For Figure 48 on Page J157)

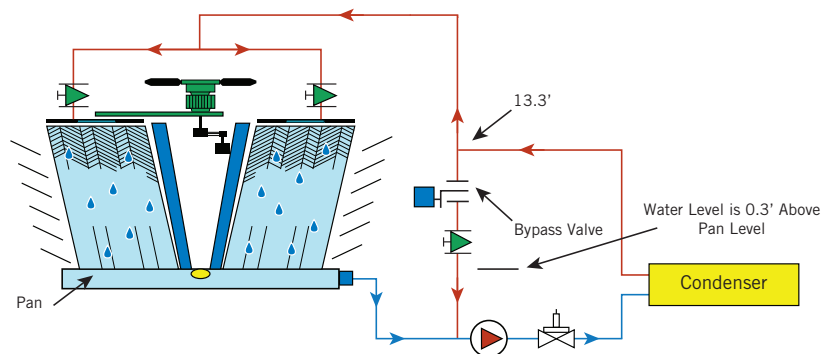

Figure 48C. Pump On; Bypass Open In Valve $C_v = 830$ (For Figure 48 on Page J157)

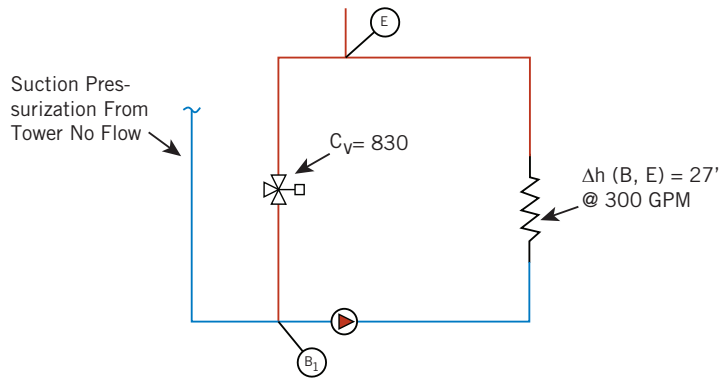

Figure 49. Tower in Total Bypass Establishes Closed Loop Operation; No Statics

The pumped piping circuit on bypass has now become a closed loop since all statics have been lost. The comparative system curves, full tower versus full bypass, can now be illustrated.

System Curve Tables:

Full Tower Flow						
Flow (GPM)	0	100	200	300	350	400
Actual Flow-Friction (Ft Head)	0	3.4	13.1	30	41	53
Static Head (Ft Head)	12	12	12	12	12	12
Total Head Loss (Ft Head)	12	15.4	25.1	42	53	65
Full Bypass Flow						
Flow (GPM)	0	100	200	300	350	400
Actual Flow-Friction (Ft Head)	0	3	12	27.3	36	47
Static Head (Ft Head)	0	0	0	0	0	0
Total Head Loss (Ft Head)	0	3	12	27.3	36	47

Table 11

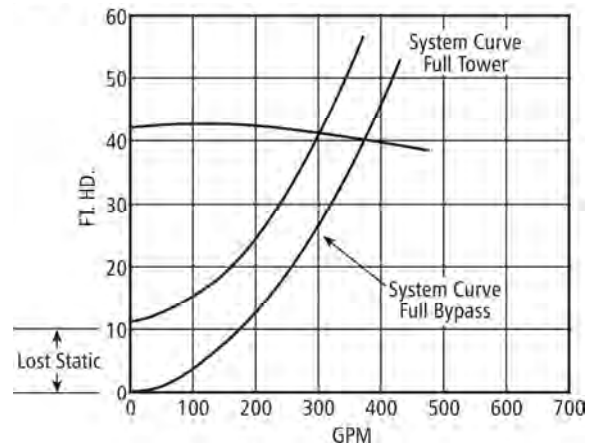

Figure 50. Pump Operating Shift Caused by Loss of Static Head

*Complete loss of all static head as caused by full bypass operation will cause a shift in pump operational point as described in Figure 50.

The pumping point shift can be virtually eliminated with reduced system cost and improved controllability by proper sizing and setting of the bypass valve.



Cooling Tower Pumping and Piping

When the bypass is to pump suction and is below tower pan level, the following application point should be observed: The valve should be selected for design flow at a head approximately equal to system static pump-height H_0 .

This is the height from tower pan water level to the topmost tower discharge piping. For the example, described in **Figure 49**, H_0 is 12 ft. At a design flow rate of 300 GPM, the valve selection point would be at $C_v = 130$.

Reference to the B&G System Syzer illustrates that a 3" valve at 60° open will satisfy the requirement. Final selection should be left to the control engineer, since it is finally and ultimately his responsibility to both select and set the valve.

It should be pointed out that the valve will often be much smaller than conventional line size. The valve must remain as the control element in the bypass line, however, and the bypass would be pipe sized to usual criteria (in this case 5 in) except for the order of 5 valve size pipe diameters up and downstream of the valve, which would be valve size.

Given proper bypass valve sizing and setting, the operating pump shift will disappear because the "lost" static head is replaced by an introduced flow-friction head.

Other Bypass Application Problems

1. High System Static Head Requirement

It will be noted that as system static pump head (H_0) increases, an intolerable valve pressure drop situation can be created. This would be especially true for a winterized penthouse tower draining into a basement receiving tank.

The application solution to **Figure 51** is a bypass to the tower sump pan or to the gravity drain line at a point directly below the tower.

It will be noted that bypass could be installed as shown in **Figure 51** given a reasonable H_0 ; a reasonable valve selection head. This will be defined by the control valve manufacturer and would generally not exceed the order of 25 ft.

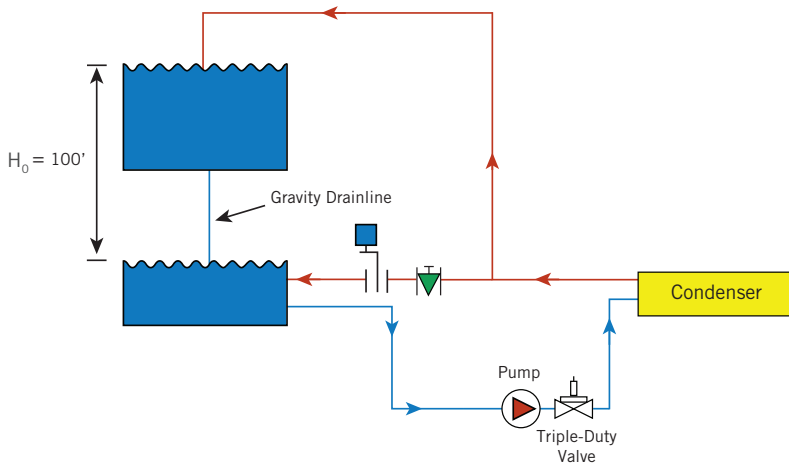

Figure 51. Intolerable Valve Sizing Situation Because of High Static H_0 - **WRONG**

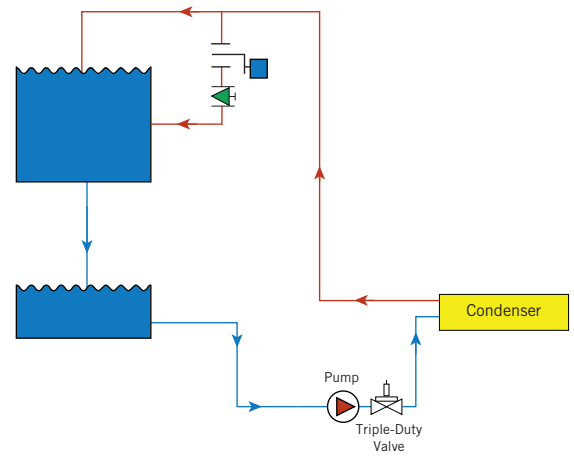

Figure 52. Bypass to Tower Solves High Static Head Bypass Problem

2. High Pressure Drop Spray Nozzle Tower with Bypass

The bypass arrangement in **Figure 53** can propose almost insurmountable pumping problems because of changes in pumping head as bypass occurs.

Pump head requirements for full tower flow will be:

$$\begin{aligned} \text{PUMP HEAD} &= H_0 + \text{Nozzle } \Delta h + \text{Friction } \Delta h \\ &= 10 + 25 + 30 \\ &= 65 \text{ ft} \end{aligned}$$

During bypass, static head will be lost, as will flow-friction head through the spray nozzles, discharge piping Δh (ED) and suction piping Δh (AB). The only pumping head that will remain will be flow-friction in the condenser and bypass loop.

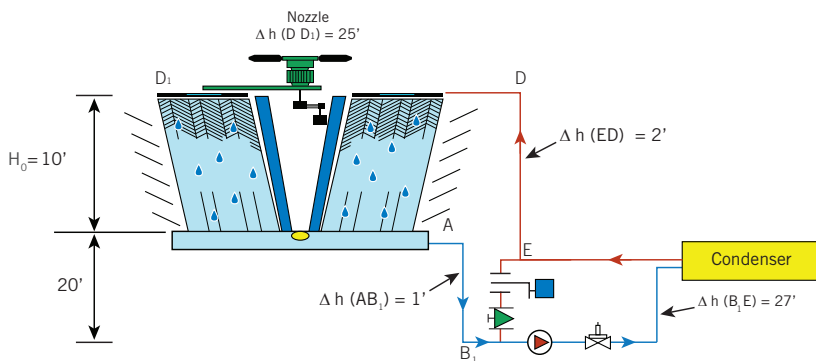

Figure 53. Bypass to Suction with HIGH Pressure Drop Spray Nozzle; Can Establish Intolerable Flow Instability

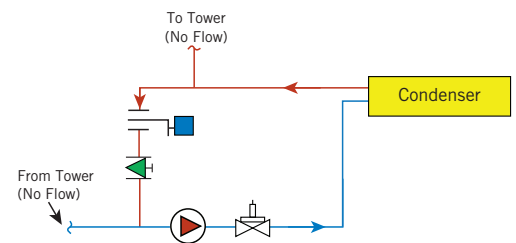

Figure 54. Open Bypass Valve Establishes Closed Loop Pumping Circuit with Lost Static and Lost Flow-Friction Head through Tower Nozzles, Suction, and Discharge Piping



Cooling Tower Pumping and Piping

Given a line sized bypass valve at wide open setting, the new pump head will only be:

PUMP HEAD = 27 + 0.3 = 27.3 ft @ 300 GPM

Pump head has now dropped from 65 ft to the order of 27 ft at design flow. This will result in a remarkable flow change as the bypass valve opens and closes; from a design 300 GPM with bypass closed to the order of 500 GPM with an open bypass.

Location of the bypass valve at a high point in the tower discharge line establishes that the pump static head H_0 will be a constant factor and is not “lost” as in **Figure 55**.

Linked butterfly valves are illustrated in **Figure 55** rather than the conventional diverting valve. This is because of a previously mentioned characteristic of linked butterflies that will, in this case, aid in providing flow stability.

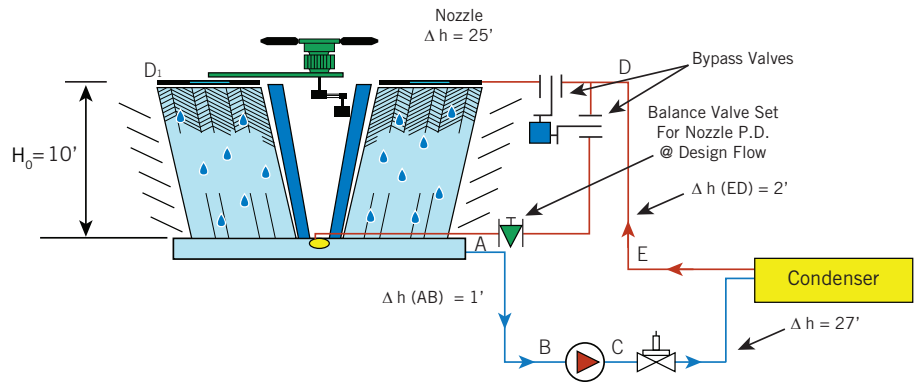

Figure 55. Bypass to Tower with Linked Butterflies and Balance Valve Provides Solution to Flow Instability Problem

The characteristic is that linked butterflies will increase flow-friction head resistance as the valves move from “one side open” to a modulating or “each valve 50% open” position. The characteristic combination valve head increase at 50%, will be to the order of 4 times that for only one side open.

When the valves move to a 50% bypass flow, flow-friction head through the spray nozzles will reduce from 25 ft to the order of 6 ft (50% flow = 25% head). The butterfly valves can now provide the “lost head” difference of 19 ft (25 – 6).

Since the lost spray nozzle head of 19 ft is to be provided at a 50% valve open condition; and since combined valve resistance head is 4 times that at a “one side open” condition. Valve selection will be to design flow and to “lost spray nozzle head” divided by 4. In this case:

Valve Selection Head = $19/4 = 4.7$ ft; say 5 ft

Assuming a design flow of 300 GPM, the example valve selection will be 300 GPM @ 5 ft or $C_v = 200$. This would be line sized butterflies (5”) at 50° open.

The balance valve illustrated in **Figure 54** serves the same function as bypass balance on a conventional hydronic three-way controlled coil; in this case it is set to spray nozzle pressure drop at design flow.

The tower piping arrangement is now basically stabilized in terms of pumping flow rates.

(a) Full Tower Flow Pump Head:

$$\begin{aligned} \text{Pump Head} &= H_o + \Delta h \text{ (AD)} + \text{Valve } \Delta h + \text{Spray } \Delta h \\ &= 10 + 30 + 5 + 25 \\ &= 70 \text{ ft} \end{aligned}$$

(b) Tower @ 50% Bypass

$$\begin{aligned} \text{Pump Head} &= H_o + \Delta h \text{ (AD)} + \text{Valve } \Delta h + \text{Spray } \Delta h \\ &= 10 + 30 + 20 + 6 \\ &= 66 \text{ ft} \end{aligned}$$

It will be noted that pump head has only decreased from 70 ft to 66 ft. This is tolerable since flow changes will be insignificant; 300 to 310 GPM.

(c) Tower @ 100% Bypass

$$\begin{aligned} \text{Pump Head} &= H_o + \Delta h \text{ (AD)} + \text{Valve } \Delta h + \text{Balance } \Delta h \\ &= 10 + 30 + 5 + 25 \\ &= 70 \text{ ft} \end{aligned}$$

3. Bypass to Suction; Condenser Above Tower Pan

Severe operating problems can be caused with pump suction bypass as illustrated in **Figure 56**. Improper valve setting will cause air to be introduced into the pump suction, causing pump “air binding” and mechanical pump troubles. These problems have been described on pages **J140 to J144**. Lost statics will cause further troubles.

The balance valve, when set, minimizes static head loss problem possibilities. The tower bypass eliminates any possibility of air draw into the pump suction as caused by bypass.

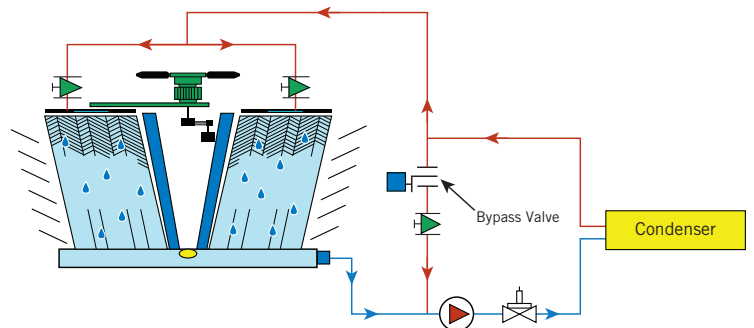

Figure 56. Possible Problem Installation; Bypass to Suction

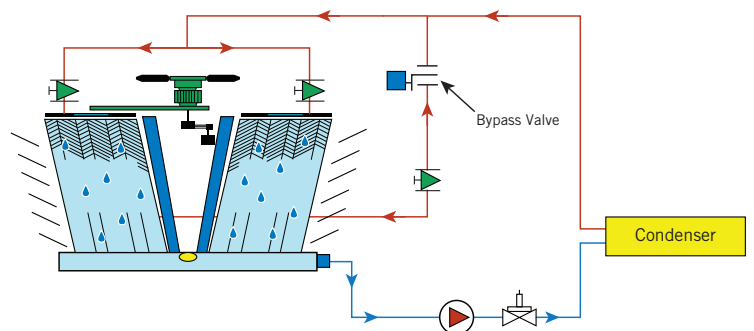

Figure 57. Bypass to Tower Eliminates Suction Air Draw Possibility and Reduces Pump Head Change



Cooling Tower Pumping and Piping

4. Condenser Above Tower

Bypass to the tower should always be employed when the condenser is located above the tower.

Given the downcomer return height H_r is greater than cancellable siphon return statics, balance valve #1 would be set in terms of previous design procedure (page J122).

Balance valve #2 is set for open system height H_o ; valve pressure drop = H_o ft for full bypass flow rate.

The linked butterfly valves would be selected for a low order of pressure drop at full design flow rate in order to minimize valve pressure drop change effect on total pumping head during partial bypass.

It will be noted that high pressure drop diverting three-way valve application may be preferable. The valves can be much smaller since there is no real concern regarding changed pressure drop on bypass. Use of a high pressure drop diverting valve would often eliminate the need for balance valve #1 as shown on **Figure 58**.

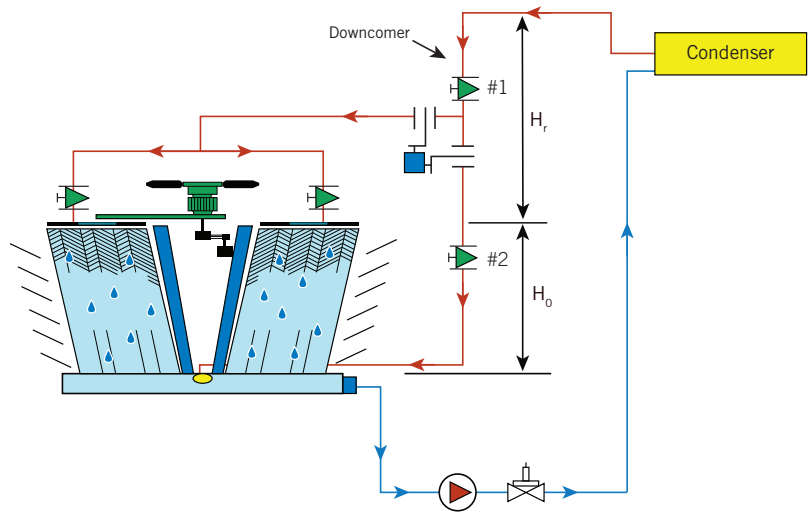

Figure 58. Overhead Condenser; Bypass to Tower with Linked Butterfly

This concludes the pumping and piping considerations covered in this handbook. For more information or considerations for special projects please contact your local BAC Representative or visit www.BaltimoreAircoil.com.



A special thanks to Bell and Gossett, a xylem brand for their contribution to this section. All content was Reprinted with permission from Xylem, Inc. Copyright 2013.

Cooling Tower Pumping and Piping



Reprinted with permission from Xylem, Inc. Copyright 2013.

> Legend



Flow-Friction Loss

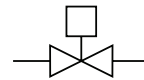

Automatic Valve



Balance Valve (Plug)

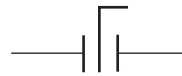

Butterfly Valve



Heat Rejection Equipment

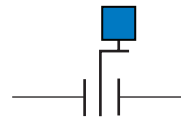

Automatic Butterfly Valve



Pump

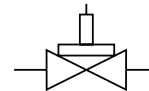

Triple-Duty Valve



Valve

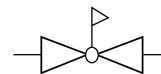

Pressure Reducing Valve



Node

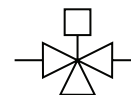

Mixing/Diverting Valve



Non-Slam Check Valve

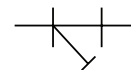

Strainer

Color Notes:

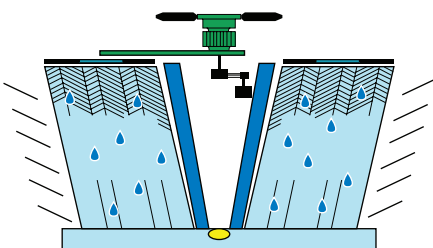

Cooling Tower