



**BALTIMORE
AIRCOIL COMPANY**



VERTEX™
EVAPORATIVE CONDENSER

OPERATION & MAINTENANCE MANUAL



✓ Recommended Maintenance Intervals^[1]

Inspect and clean as necessary:	Start-Up	Monthly	Quarterly	Annually	Shutdown
Inspect general condition of the unit ^[2] and check unit for unusual noise or vibration	✓	✓			
Inspect basin	✓		✓		
Flush water distribution system/Inspect spray nozzles	✓		✓		
Clean basin strainer	✓	✓			✓
Clean water guards	✓		✓		
Drain basin and piping	✓				✓
Check and adjust water level in basin	✓	✓			
Check operation of make-up valve	✓	✓			
Inspect coil			✓		
Check and adjust bleed rate	✓	✓			
Inspect unit finish				✓	
Mechanical equipment system:	Start-Up	Monthly	Quarterly	Annually	Shutdown
Check belt condition ^[4]	✓	✓			
Adjust belt tension ^{[3][4]}	✓		✓		
Lubricate fan shaft bearings ^[4]	✓		✓		✓
Lubricate motor base adjusting screw ^[4]	✓		✓		✓
Check drive alignment ^[4]				✓	
Check motor voltage and current	✓		✓		
Clean fan motor exterior	✓		✓		
Check fan motor for proper rotation	✓				
Check general condition of the fan	✓		✓		
Check fan for uniform pitch ^[4]			✓		
Check fan for rotation without obstruction	✓		✓		
Check and recoat steel shafts with RUST VETO ^{®[4]}	✓		✓		✓
Check optional basin heater and stand alone BAC heater control panel				✓	
Test optional vibration cutout switch ^[4]	✓			✓	



DANGER: Rotating equipment will cause severe personal injury or death to persons who come in contact. Do not perform any service on or near the fans, motors, and drives, or inside the unit without first ensuring that the fans and pump motors are disconnected, locked out, and tagged out.



NOTES:

1. Recommended service intervals are the minimum for typical installations. Harsh environmental conditions may dictate more frequent servicing.
2. When operating in ambient temperatures below freezing, the unit should be inspected more frequently. Refer to “Cold Weather Operation” on **page 24** for more details.
3. Tension on new belts must be readjusted after the first 24 hours of operation and quarterly, thereafter.
4. On units equipped with BALTIDRIVE[®] Power Train only.



Table of Contents

OPERATION & MAINTENANCE » VERTEX™ EVAPORATIVE CONDENSER

Warnings and Cautions

- 2 Safety Precautions
- 3 Equipment Precautions
- 3 General Maintenance Information

PART 1 Unit Operation and Storage

- 4 Start-Up Procedure
- 6 Extended Shutdown
- 7 Prolonged Outdoor Storage

PART 2 Detailed Component Maintenance Procedures

- 10 Basin
- 11 EC Fan System
- 12 BALTIDRIVE® Power Train
- 15 Water Distribution and Heat Transfer Section
- 16 Water Level Control

PART 3 Corrosion Protection

- 18 Water Treatment
- 19 Corrosion and Scale Control
- 19 Gray Water and Reclaimed Water
- 20 Chemical Treatment Requirements
- 20 Passivation
- 20 Biological Control
- 21 Long Term Care of Stainless Steel
- 22 System Cleaning

PART 4 Bleed Rate

- 23 Bleed Rate

PART 5 Cold Weather Operation

- 24 Inspection & Maintenance
- 24 Fan Section Icing Protection
- 25 Basin Water and Internal Piping Freeze Protection
- 26 Coil Freeze Protection

PART 6 Operation Considerations for Accessories

- 27 Basin Heater (Optional)
- 27 Stand Alone BAC Heater Control Panel (Optional)
- 29 Vibration Cutout Switch (VCOS)

Part 7 Fan Control

- 30 EC Fan System Fan Control
- 31 EC Fan System Troubleshooting
- 34 BALTIDRIVE® Power Train
- 34 Independent Fan Control (Optional)
- 35 Variable Frequency Drive Operation
- 35 Resonant Speed Identification Procedure

PART 8 Installation Instructions for Field Connections – TriArmor® Corrosion Protection System Basin

- 37 Installation Instructions

Safety Precautions



DANGER

- **DANGER:** Rotating equipment will cause severe personal injury or death to persons who come in contact. Do not perform any service on or near the fans, motors, and drives, or inside the unit without first ensuring that the fans and pump motors are disconnected, locked out, and tagged out.



WARNING

- **WARNING:** The top horizontal surface of the unit is not intended to be used as a walking surface or working platform. If access to the top of the unit is desired, the purchaser/end-user is cautioned to use appropriate means complying with OSHA or other applicable safety standards of governmental authorities.
- **WARNING:** When the fan speed of the unit is to be changed from the factory set speed, including changes achieved by the use of a variable fan speed device, steps must be taken to avoid operation at or near the fan's "critical speed" which could result in fan failure and possible personal injury or damage. Contact your local BAC Representative regarding any such applications.
- **WARNING:** The recirculating water system may contain chemicals or biological contaminants, including Legionella, which could be harmful if inhaled or ingested. Personnel exposed directly to the discharge airstream and the associated drift mists, generated during operation of the water distribution system and/or fans, or mists produced by high pressure water jets or compressed air (if used to clean components of the recirculating water system), must wear respiratory protection equipment approved for such use by governmental occupational safety and health authorities.
- **WARNING:** A lockable disconnect switch should be located within sight of the unit for each fan motor associated with this equipment. Before performing any type of service or inspection, make certain that all power has been disconnected, and the switch is locked out in the "OFF" position.



CAUTION

- **CAUTION:** The operation, maintenance, and repair of this equipment shall be undertaken only by personnel authorized and qualified to do so. All such personnel shall be thoroughly familiar with the equipment, the associated system and controls, and the procedures set forth in this manual. Proper care, personal protective equipment, procedures, and tools must be used in handling, lifting, installing, operating, maintaining, and repairing this equipment to prevent personal injury and/or property damage.
- **CAUTION:** This equipment should never be operated without all fan screens, access panels, and access doors in place.
- **CAUTION:** All electrical, mechanical, and rotating machinery are potential hazards, particularly for those not familiar with their design, construction, and operation. Accordingly, use appropriate lockout procedures. Adequate safeguards (including the use of protective enclosures where necessary) should be taken with this equipment both to safeguard the public from injury and to prevent damage to the equipment, its associated system, and the premises.
- **CAUTION:** Openings and/or submerged obstructions may exist in the bottom of the basin. Use caution when walking inside this equipment.
- **CAUTION:** Do not use the plastic drift eliminators as a walking, working, or storage surface. Stepping on or placing weight on an eliminator can result in physical injury and/or equipment damage. After ensuring that the fan and pump motors are locked and tagged out, lift and remove eliminators as necessary to perform recommended maintenance and inspections. If access to the top of the coil is required, place a piece of plywood at least 1/2 inch thick on top of the coil to protect the surface while performing the recommended maintenance. When finished, carefully remove the plywood and re-install any eliminators which were removed.
- **CAUTION:** Combined inlet shields can separate from the product during high winds. Fasten combined inlet shields in place using the retaining system.

Equipment Precautions



NOTICE

- BAC units are typically installed immediately after shipment and many operate year round. However, if the unit is to be stored for a prolonged period of time either before or after installation, certain precautions should be observed, as outlined in “Unit Operation and Storage” on **page 4**.
- Mechanical and operational methods must be employed to protect these products against damage and/or reduced effectiveness due to possible freeze-up. Please refer to www.BaltimoreAircoil.com or contact your local BAC Representative for recommended protection alternatives.
- The basin heater is not designed to prevent icing during unit operation.
- The heater control panel temperature/low level control can only be used with the supplied combination temperature/liquid level sensor probe.
- For the stand alone BAC heater control panel, Do not operate the system unattended or for extended periods of time during test mode (resistor across terminals T1 and T2). Operation in water temperatures above 45°F (7.2°C) could damage the unit.
- For heater control panels, do not operate the system unattended or for extended periods of time with terminals G1-G2 jumpered. A low liquid level condition could occur, and the system will not shut off which could result in damage to the heater and unit.
- Check to ensure the controls for the fan motor are set to allow a maximum of six on-off cycles per hour to prevent motor overload.
- With a switching frequency of 2.5 kHz, the line lead length cannot exceed 100 feet. If the switching frequency is higher than 2.5 kHz and/or the line lead length exceeds 100 feet, a dV/dT output filter is recommended to protect the motor.
- For fan motors controlled with VFDs, when reversing the direction of fan rotation, allow the fan to come to a complete stop before restarting the motor.
- Only lubricate the bearings with one of the compatible water resistant greases listed on **page 14**.
- Do not use steam or high pressure water to clean PVC eliminators or materials other than steel.
- Spray system pressure greater than 10.0 psig may cause damage to the distribution system.
- Never use chloride or chlorine based solvents such as bleach or muriatic (hydrochloric) acid to clean stainless steel. It is important to rinse the surface with warm water and wipe with a dry cloth after cleaning.

General Maintenance Information

The services required to maintain a piece of evaporative cooling equipment are primarily a function of the quality of the air and water in the locality of the installation:

- **AIR:** The unit should be located such that unusual quantities of industrial smoke, chemical fumes, salt, or heavy dust do not enter the equipment. Such airborne impurities entering into the equipment and absorbed by the recirculating water, which can form a corrosive solution.
- **WATER:** As water evaporates from the equipment, dissolved solids from the make-up water are left behind. These dissolved solids may be either alkaline or acidic, and as they are concentrated in the circulating water, they can cause scaling or accelerated corrosion.

The extent of impurities in the air and water determines the frequency of most maintenance services and also governs the extent of water treatment which can vary from a simple continuous bleed and biological control to a sophisticated treatment system. Refer to “Water Treatment” on **page 18** and “Biological Control” on **page 20** for more details.

Please refer to the Limitation of Warranties in the submittal packet applicable to and in effect at the time of the sale/purchase of these products. Described in this manual are the recommended services for start-up, operation, and shutdown, and the approximate frequency of each.

1

VERTEX™ EVAPORATIVE CONDENSER

Unit Operation and Storage

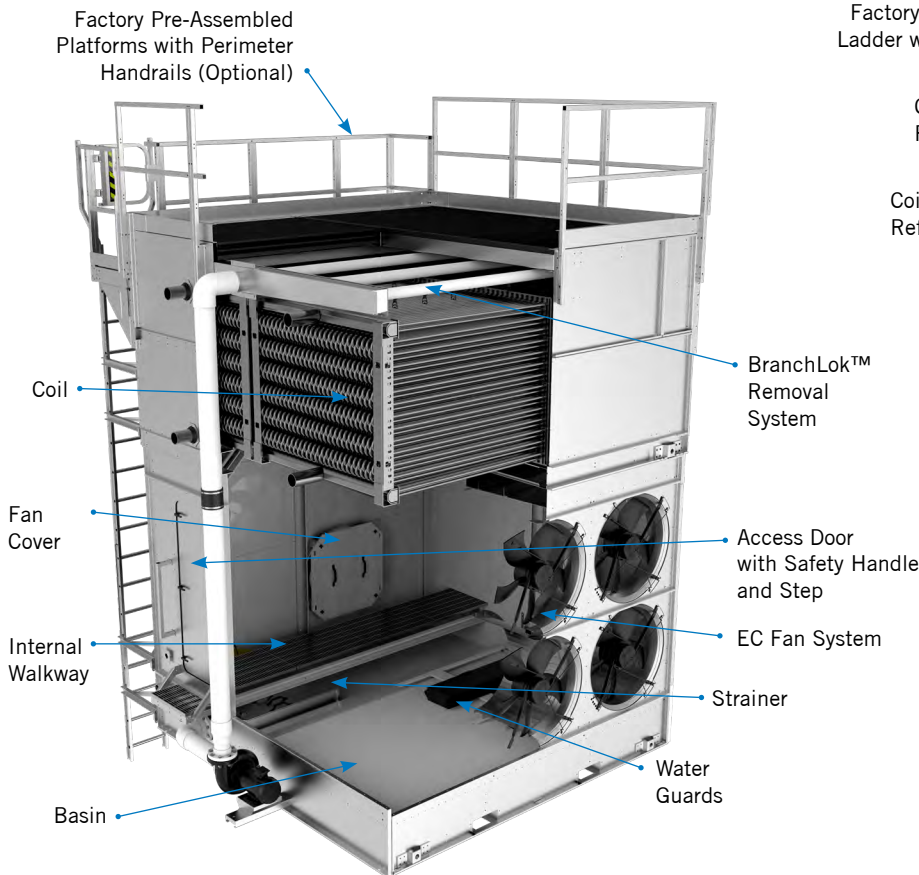
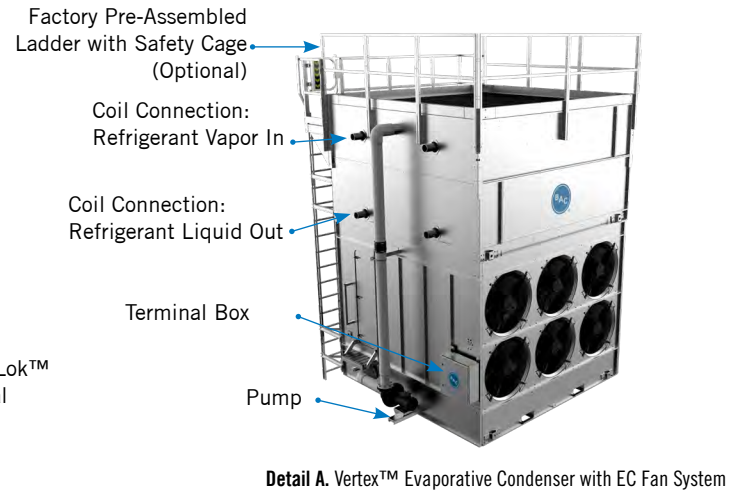

Figure 1. Vertex™ Evaporative Condenser



Detail A. Vertex™ Evaporative Condenser with EC Fan System



Detail B. Vertex™ Evaporative Condenser with BALTIDRIVE® Power Train (Optional)

Start-Up Procedure

Considerations for Initial Start-Up

- For units with independent fan control [standard on units with the BALTIDRIVE® Power Train], see **page 34**.
- For units with VFDs, see **page 35**.
- For units with vibration cutout switches, see **page 29**.

General

- If the unit is mounted on vibration isolators or isolation rails (by others), refer to the vibration isolation manufacturer's guidelines before loading/unloading weight from the unit.
- Verify fans and the pump motor are disconnected, locked out, and tagged out.
- The unit must be level in both the length and width directions for proper operation.

Cleaning

- Drain the basin with the strainer in place.
- Remove all dirt and debris from the fan guard(s) and combined inlet shields.
- Inspect and clean all spray nozzles.
- Clean all of the mechanical components, such as the fan and motor.
- Remove accumulated dirt and debris from the water guards.
- Flush the basin to remove any accumulated dirt and debris.
- Remove, clean, and replace the basin strainer.

Inspection

- Conduct external inspection of the equipment. Check for leaks, corrosion, and any structural damage.
- Conduct internal inspection of the equipment. Check for anything unusual such as structural or mechanical component damage.
- Inspect piping and connections.
- Thoroughly inspect the fans for any mechanical or physical damage.
- At seasonal start-up or after prolonged shutdown, check the motor insulation with an insulation tester prior to the motor start-up.
- Check and adjust the belt tension. Units equipped with the EC Fan System use direct drive motors and do not require belt tension.

Start-Up

- For BALTDRIIVE® Power Train units only, prior to seasonal start-up, lubricate the motor base adjusting screw (see **Figure 3** on **page 12**) and the fan shaft bearings (see **page 14**). At initial start-up, no bearing lubrication is required since the bearings are factory lubricated prior to shipment.
- For BALTDRIIVE® Power Train units only, apply RUST VETO® to steel shafts.
- Fill the basin with fresh water to the overflow level via the make-up valve.
- Set the make-up valve float so the water shuts off at the operating level (see **Table 1** on **page 10**).
- Execute one of the following biocide treatment programs while operating the circulating pump and prior to operating the unit fans:
 - Resume treatment with the biocide that was used prior to shutdown. Operate the pump only while maintaining the maximum recommended biocide residual for a sufficient duration (residual and time will vary with the biocide) as recommended by the water treatment supplier. Start the fan only after this treatment period is completed.
 - Check the pH of the circulating water and, if necessary, adjust it to 7.0 - 7.6 pH. Then, running the pump only, treat the system with sodium hypochlorite to maintain a level of 4 to 5 mg/l (ppm) free chlorine (as Cl₂) over a six hour period. Test kits for measuring the free residual of chlorine are commercially available. Start the fan only after this treatment period is completed.



Unit Operation and Storage

Start-Up Procedure

- Considerations for Initial Start-Up
- General
- Cleaning
- Inspection
- Start-Up



DANGER: Rotating equipment will cause severe personal injury or death to persons who come in contact. Do not perform any service on or near the fans, motors, and drives, or inside the unit without first ensuring that the fans and pump motors are disconnected, locked out, and tagged out.

NOTICE: Spray system pressure greater than 10.0 psig may cause damage to the distribution system.



NOTICE: Check to ensure the controls for the fan motor are set to allow a maximum of six on-off cycles per hour to prevent motor overload.



After 24 hours of operation under thermal load, perform the following services:



- ✓ Check the unit for any unusual noises or vibrations.
- ✓ Check the operating water level in the basins.
- ✓ Adjust the make-up valve if necessary.
- ✓ Check the belt tension and readjust if necessary.
- ✓ Inspect the spray nozzles and heat transfer section.

DANGER: Rotating equipment will cause severe personal injury or death to persons who come in contact. Do not perform any service on or near the fans, motors, and drives, or inside the unit without first ensuring that the fans and pump motors are disconnected, locked out, and tagged out.



- Start the unit pump and check for the proper rotation indicated by the arrow on the pump cover.
- On installations where the unit pump was not furnished by BAC, a globe valve should be installed in the pump discharge line and the pump flow rate adjusted to the correct water flow and pressure (2.25 psig at spray header connection).
- Check that the float operated make-up valve is operating freely. Closely monitor the water level and adjust as necessary during the first 24 hours of operation.
- Inspect the nozzles and heat transfer section as described in “Water Distribution and Heat Transfer Section” on **page 15**.
- For units with the BALTIDRIVE® Power Train, verify proper fan tip clearance. See **page 12**.
- Open the valve in the unit bleed line, and adjust the bleed by closing or opening the valve until the desired bleed rate is reached.
- For initial start-up, briefly energize the fan motor(s) and note the direction of rotation. The fan should rotate in the direction indicated by the arrow on the fan cowl.
- Run the fan in manual mode for several minutes to check for any unusual noise or vibrations.
- For a 2-speed motor, check to ensure the starter includes a minimum 15 second time delay when switching from high speed to low speed.
- Check the operation of the optional vibration cutout switch.
- Once the unit is operating, check the current and voltage of all three phases (legs) of the fan motor with a heat load on the unit under warm ambient conditions. The current must not exceed the motor nameplate rating.

Extended Shutdown

Perform the following services whenever the unit is shutdown in excess of three days:

- If the unit is mounted on vibration isolators or isolation rails (by others), refer to the manufacturer's guidelines before loading/unloading weight from the unit.
- Disconnect, lock out, and tag out the fans, pump, and motors.
- Close the shut-off valve in the make-up water line (supplied by others), and drain the basin and all exposed water piping. Heat trace and insulate all exposed piping.
- To minimize the risk of biological contamination during shutdown, it is recommended the entire system be drained.
- Clean all debris, such as leaves and dirt, from the interior and exterior of the unit, including the combined inlet shields.
- Clean and flush the basin with the basin strainer in place.
- Leave the basin drain open so rain and melting snow will drain from the unit.
- Remove the bottom drain plug to the spray pump(s). Put the plug(s) in a marked plastic bag and attach to the spray pump(s) for future use.
- Clean the basin strainer and re-install.
- Cover the fan discharge to keep out dirt and debris.
- Lubricate the fan shaft bearings, motor base, and motor base adjusting screw (if applicable).



Start-Up Procedure

Start-Up

Extended Shutdown

Prolonged Outdoor Storage

Storage Preparation

Prolonged Outdoor Storage

Storage Preparation

- Conduct the “Extended Shutdown” procedure on **page 6** if the unit is installed.
- Ensure the basin is fully drained and the drain is open.
- For storage prior to installation, all components and accessories, which sometimes ship inside the unit and are not a permanent fixture in the basin, should be removed and stored indoors.
- Remove the bottom drain plug to the spray pump(s). Put the plug(s) in a marked plastic bag and attach to the spray pump(s) for future use.
- Remove and store fan belts (if supplied) at room temperature. Tag belts appropriately for future identification.
- During storage, the coils should be charged with inert gas and capped. Note that coils with steel connections are charged with 15 psig nitrogen at the factory prior to shipment.
 - If the condenser is removed from the system, charge the coil with 15 psig of inert gas and cap the connections to reduce the risk of internal corrosion.
- Apply a weather-resistant lubricant or heavy grease such as Anti-Seize (BAC Part # 160069) to all exposed threaded or flanged connections and the adjustable motor base threaded rod.
- Insert desiccant bags into the control panel (if supplied) to absorb moisture. Seal the control panel for storage.
- Spray coat electrical component housings (if supplied) with a suitable protective coating, such as Cosmoline® Weathershed, and individually cover them with plastic, taking care to leave openings for free air circulation.
- Inspect the protective finish on the unit. Clean and refinish as required. Refer to “Corrosion Protection” on **page 18** for more details.



NOTICE: Covering the unit with a clear plastic tarpaulin during storage can trap heat inside the unit and cause damage to the PVC components. If units must be covered during storage, an opaque, reflective tarp with vents should be used.

Motor Recommendations



Figure 2a. Vertex™ Evaporative Condenser with EC Fan System



Figure 2b. Vertex™ Evaporative Condenser with BALTIDRIVE® Power Train (Optional)

Electronically Commutated (EC) Motors

Vertex™ Evaporative Condenser EC motors are designed for storage at ambient temperatures of -40°F to 176°F (-40°C to 80°C). Prolonged periods of exposure above or below these specified conditions could degrade components of the motor and cause malfunction or premature failure.

- Care must also be taken to protect the motor from flooding or from harmful chemical vapors.
- The storage area should be free from ambient vibration. Excessive vibration can cause damage.
- Keep stored motor(s) dry and protected from weather.
- Rotate the fan once per month.
- Precautions should be taken to prevent rodents, snakes, birds, or other small animals from nesting inside the motors. In areas where they are prevalent, precautions must also be taken to prevent insects from gaining access to the interior of the motor.

BALTIDRIVE® Power Train

BAC standard motors are designed for storage at ambient temperatures of -20°F to 104°F (-28.9°C to 40°C). Prolonged periods of exposure above or below these specified conditions could degrade components of the motor and cause malfunction or premature failure.

- Motors should be removed and stored inside whenever possible. When indoor storage is not possible the motors must be covered with a tarpaulin. Do not use plastic or plastic film. This cover should extend below the motor and be secured; however, it should not tightly wrap the motor. This will allow the captive air space to breathe, minimizing formation of condensation.
- Care must also be taken to protect the motor from flooding or from harmful chemical vapors.
- The storage area should be free from ambient vibration. Excessive vibration can cause bearing damage.

DANGER: Rotating equipment will cause severe personal injury or death to persons who come in contact. Do not perform any service on or near the fans, motors, and drives, or inside the unit without first ensuring that the fans and pump motors are disconnected, locked out, and tagged out.





Prolonged Outdoor Storage

- Motor Recommendations
- Maintenance Requirements During Storage
- Start-Up Preparation After Prolonged Storage

- Precautions should be taken to prevent rodents, snakes, birds, or other small animals from nesting inside the motors. In areas where they are prevalent, precautions must also be taken to prevent insects from gaining access to the interior of the motor.
- If not stored indoors in a controlled environment, some form of heating must be utilized to prevent condensation from accumulating in the motor. This heating should maintain the winding temperature at a minimum of 9°F (5°C) above the ambient temperature of the surrounding environment, keeping it from dropping below the dew point where condensation could form inside the motor. If space heaters are supplied, they should be energized. Request the required voltage and transformer capacity from your local BAC Representative. A third option is to use an auxiliary heat source and keep the winding warm by either convection or blowing warm air into the motor.
- Rotate the motor shaft monthly to redistribute bearing grease.

Maintenance Requirements During Storage

- Rotate all fans and motor shafts monthly by hand. Hand-turning will ensure that the shafts and bearings are free and will redistribute grease within the bearings.
- Inspect the basin monthly to ensure that the drain is open and remove any leaves or debris that may have accumulated on the water guards and in the basin.
- Inspect the axial fans annually to ensure the blades are tight and there is no obvious corrosion between the hub and the fan blade.
- Inspect the rust preventative coating on all motor external machined surfaces including shaft extensions monthly. If necessary, re-coat the surfaces with RUST VETO®.

Start-Up Preparation After Prolonged Storage

Keep in mind that start-up procedures after long periods of storage are just as important as pre-shutdown procedures.

- Motors should be thoroughly inspected, cleaned, and restored to pre-storage condition.
- Inspect axial fans prior to start-up to ensure that the blades are tight and that there is no obvious corrosion between the hub and the fan blade. Do not energize the fans if there is obvious corrosion of fan components. Loose fan blades could result in fan failure and possible injury or damage.
- Reinstall all fan belts, motors, door gaskets, and drain plugs (as applicable), and remove all protective coverings.
- For units stored prior to installation, conduct rigging procedures as directed in the unit's *Rigging and Assembly Instructions*, available on www.BaltimoreAircoil.com or by contacting your local BAC Representative.
- Perform an insulation test of motor windings to ensure satisfactory insulation resistance.
- Conduct full start-up procedure as stated in the "Start-Up Procedure" on **page 4**. Be especially thorough for cleaning and inspection prior to start-up.

Detailed Component Maintenance Procedures

Basin

The basin is constructed from one of the following materials of construction and the following maintenance applies to all basin materials of construction.

- Galvanized steel
- TriArmor® Corrosion Protection System
- Welded Type 304 stainless steel

Water Levels

Model Number	Operating Depth (in)	Operating Height (in)	Operating Volume (gal)	Overflow Volume (gal)
VRC-xxxxA-1012N-xx	9	15.43	254	479
VRC-xxxxA-1018N-xx	9	15.43	385	701
VRC-xxxxA-1024N-xx	9	15.43	508	959
VRC-xxxxA-1036N-xx	9	15.43	770	1402
VRC-xxxxA-2012N-xx	9	15.43	508	959
VRC-xxxxA-2018N-xx	9	15.43	770	1402
VRC-xxxxA-1212N-xx	9	15.43	254	521
VRC-xxxxA-1218N-xx	9	15.43	385	774
VRC-xxxxA-1224N-xx	9	15.43	508	1,042
VRC-xxxxA-1236N-xx	9	15.43	770	1,549
VRC-xxxxA-2412N-xx	9	15.43	508	1,042
VRC-xxxxA-2418N-xx	9	15.43	770	1,549

Table 1. Basin Water Levels (Measured From Inside the Basin)

- Height is measured from unit's base (mounting point) to water level. Depth is measured from the interior basin floor to water level.
- The operating water level in the basin will vary with system thermal load (evaporation rate), the bleed rate employed, and the make-up water supply pressure.
- The make-up valve controls the operating level, which should be maintained at the levels shown in **Table 1**.
- Check the operating water level monthly, and readjust the float when necessary to maintain the recommended operating level.

Inspection & Maintenance

- Inspect the basin monthly. Remove trash or debris that may have accumulated in the basin or on the strainer.
- Quarterly, or more often if necessary, drain, clean, and flush the entire basin with fresh water. This will remove the sediment, which can collect in the basin during operation. If not removed, sediment can become corrosive and cause deterioration of the protective finish of metallic basins.
 - When flushing the basin, leave the strainer in place to prevent the sediment from re-entering the spray pump.
 - Remove the strainer after the basin has been flushed.
 - Clean and replace the strainer before refilling the basin with fresh water.
 - Remove accumulated dirt and debris from the water guards.
- Adjust the float to maintain the design operating level. See **Table 1**.



Detailed Component Maintenance Procedures

Basin

Water Levels

Inspection & Maintenance

EC Fan System

EC Fan Motors

Unit Mounted Electrical Panel

Alarm Signal

EC Fan System



CAUTION: Openings and/or submerged obstructions may exist in the bottom of the basin. Use caution when walking inside this equipment.

For units supplied with electronically commutated (EC) motors, very little maintenance is required. As the fans are provided with sealed bearings, lubrication is not required.

- With the fans running, check for any unusual noises or vibrations.
- Thoroughly inspect the fans for damaged or deteriorated fan blades and replace the fan system as required.

Electronically Commutated (EC) Fan Motors

An EC motor has been designed to accept an AC power supply and use onboard electronics to operate similarly to a permanent magnet brushless DC motor. All EC motors provided by BAC have an onboard speed control module, eliminating the need for VFDs. To optimize thermal efficiency, all fans will ramp up or down simultaneously.

Unit Mounted Electrical Panel

All EC motors are factory-wired to the unit-mounted electrical control panel. This panel provides a single location for a 3-phase power connection, a 4-20 mA motor control signal, and an alarm feedback signal. Two LED lights, one for the ALARM (red) and one for the OVERRIDE (yellow), are provided on the outside of the control panel. An override switch (ON/OFF) is provided on the enclosure, allowing the operator to override an alarm condition and continue equipment operation.

Alarm Signal

The alarm light indicator (red) on the control panel indicates that one or more fans have had an event that is preventing them from operating correctly. When the indicator illuminates, all fans will operate at a factory pre-set emergency speed, which is around 40% of full speed.

Override Switch

The override switch bypasses the alarm signal coming from one or more fans and allows the user to regain control of the fans using the 4-20mA speed signal. This switch should be used when waiting for a fan replacement or if one or more fans are de-energized for any reason. If the unit must operate at higher speeds than the emergency speed, install the included fan cover over the inoperable fan to prevent water from leaving the fan housing.



DANGER: Rotating equipment will cause severe personal injury or death to persons who come in contact. Do not perform any service on or near the fans, motors, and drives, or inside the unit without first ensuring that the fans and pump motors are disconnected, locked out, and tagged out.

BALTDRIVE® Power Train

NOTICE: Check to ensure the controls for the fan motor are set to allow a maximum of six on-off cycles per hour to prevent motor overload.



- If the unit is already in operation, while the fan is running, check for any unusual noises or vibrations.
- With the fan off and the fan motor disconnected, locked out, and tagged out, check the general condition of the fan:
 - Inspect for any loose or missing bolts in the fan shaft bushing, the fan hub, and the fan shaft bearing(s).
 - Check the fan blades for looseness, first by twisting the blade by hand, and then by moving the blade tip forward and back. There should be no play or slippage.
 - Inspect each blade for excessive scale build-up that could cause vibration.
 - Check each blade for any cracks. If cracks are found, the fan motor should be locked out until the fan is replaced. Contact your local BAC Representative for assistance.
- **Tip Clearance:** Check the clearance between the tip of the blade and the fan cowl.
- The clearance should be between 3/16" to 1/4".

- **Blade Pitch:** Check to ensure that the blades are all at the same pitch. If uncertain, measure the pitch with an inclinometer. All blades should be within 1/2° of each other.
- **Rotation:** Turn the fan by hand to ensure that it moves freely with no rough spots, binding, or other malfunctions that could cause vibration or fan motor overload. While rotating the fan, check the blade tracking. All blades should track within a 1/2" band at any single point around the cowl.
- **Direction of Rotation:** On initial start-up, or if the fan motor has been rewired, briefly energize the

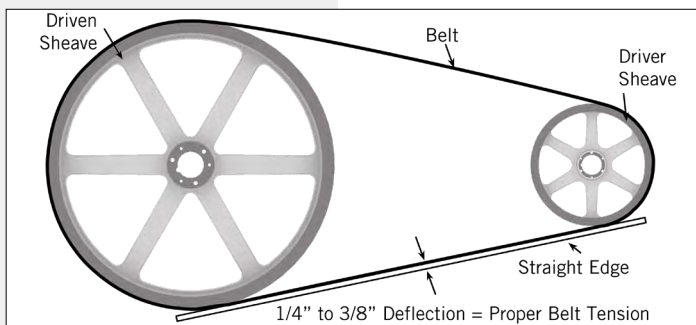

Figure 3a. Belt Tension with a Straight Edge

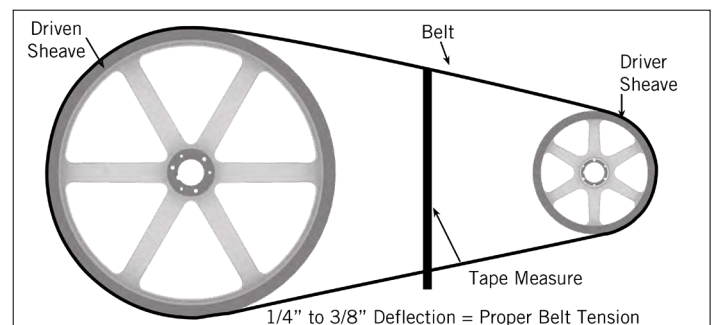

Figure 3b. Belt Tension with a Tape Measure



BALTIDRIVE® Power Train

Drive System Inspection & Maintenance

• Belt tension check:

- Place a straight edge along the belt from sheave to sheave as shown in **Figure 3a**, or use a tape measure as shown in **Figure 3b** to measure belt deflection.
- Apply a moderate force by hand (approximately 40 lbs/275 kPa) evenly across the width of the belt in the center of the span between the sheaves.
- There is adequate belt tension if the belt deflects between 1/4" and 3/8" as shown in **Figures 3a** and **3b**.

• Belt tension adjustment (if required):

- Using a wrench or impact gun, turn the motor base adjusting screw (**Figure 4**) clockwise to tension the belt or counterclockwise to relieve belt tension. During adjustment of the belt tension, rotate the drives several times by hand to evenly distribute the tension throughout the belt.



Figure 4. Motor Adjusting Screw

• Drive alignment check and adjustment:

- Place a straight edge across the driver and the driven sheaves as shown in **Figure 5**.
- The straight edge should contact all four points as shown in **Figure 5** indicating that the drives are properly aligned.
- There should be no more than 1/16" deviation from the four points of contact.
- In case of realignment, loosen the driver sheave, and align it with the driven sheave. Allow 1/4" for draw-up as the bushing screws are retightened.

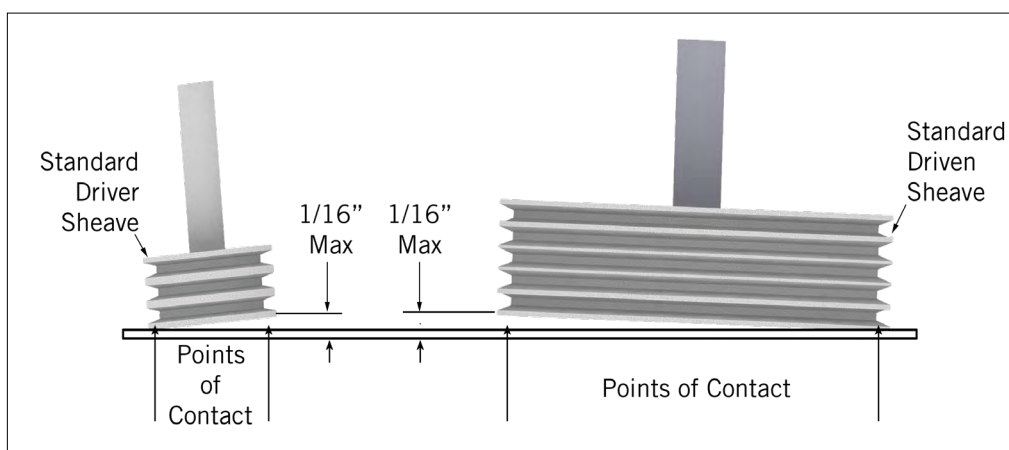

Figure 5. Drive Alignment

Adjustable Motor Base

Coat the motor base slides and adjusting screws (refer to **Figure 5**) prior to start-up, every three months while in operation, and following shutdown. Use good quality, corrosion inhibiting grease such as one of those recommended for lubricating the fan shaft bearings on **page 14**.



NOTE: If belts are properly tensioned, there should be no “chirp” or “squeal” when the fan motor is started.



DANGER: Rotating equipment will cause severe personal injury or death to persons who come in contact. Do not perform any service on or near the fans, motors, and drives, or inside the unit without first ensuring that the fans and pump motors are disconnected, locked out, and tagged out.

NOTICE: Check to ensure the controls for the fan motor are set to allow a maximum of six on-off cycles per hour to prevent motor overload.



Fan Motor Inspection & Maintenance

- Clean the outside of the motor at least quarterly to ensure proper motor cooling.
- After prolonged shutdowns, check the motor insulation with an insulation tester prior to restarting the motor.
- Check the motor voltage and current following start-up and every three months while in operation.

Fan Shaft Bearing Inspection & Maintenance

- For all units ordered with the BALTIDRIVE® Power Train, two pillow block ball bearings support the fan shaft and are provided with extended lube lines as standard on the Vertex™ Evaporative Condenser. Each bearing is equipped with a lubrication fitting and a locking collar to keep out moisture.
- Only lubricate the bearings with a manual grease gun or BAC's optional Automatic Bearing Greaser. Do not use high-pressure grease guns since they may rupture the bearing seals or the extended lubrication lines.
- Only lubricate the bearings with one of the following compatible water resistant greases which are suitable for ambient temperatures ranging from -65°F (-53.9°C) to +250°F (121.1°C).
 - Amoco - Rycon Premium #3
 - Chevron - SRI
 - Citgo - Polyurea MP2™
 - Conoco - Polyurea 2™
 - Exxon - Polyrex® EM
 - Exxon - Unirex N™
 - MobilGrease® - AW2
 - Shell - Gadus S2 V100 3
 - Shell - Gadus S3 T100 2
 - SKF - LGHP2™
 - Unocal 76 - Unilife Grease™
- Lubricate the bearings as follows:
 - **Initial Start-Up:** Normally, no lubrication is required since the bearings have been lubricated at the factory prior to shipment. However, if the unit has been stored at the job site for more than three months, both bearings should be lubricated with new grease before initial operation. When lubricating, purge the old grease from the bearing by gradually adding grease until a bead of new grease appears at the seal on the underside of the bearing.
 - **Seasonal Start-Up:** Purge the bearings with new grease prior to start-up.
 - **Operation:** Purge the bearings with new grease every three months while in operation.
 - **Extended Shutdown:** Purge the bearings with new grease prior to any prolonged storage or downtime.

Locking Collars

Each eccentric locking collar should be checked quarterly to ensure that the inner bearing race is secured to the fan shaft. The locking collar can be set using the following procedure (see **Figure 6**):

- Loosen the set screw.
- Using a drift pin or center punch, tap the collar (in the hole provided) tangentially in the direction of rotation while holding the shaft.
- Retighten the set screw.

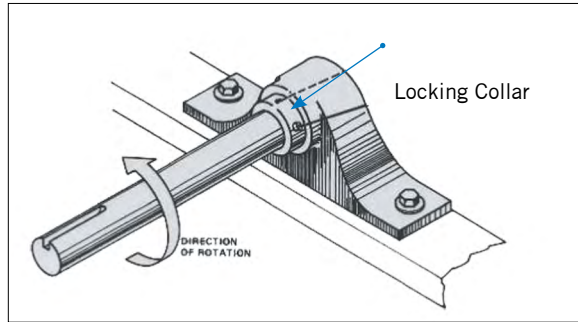

Figure 6. Locking Collar Assembly

Water Distribution System and Heat Transfer Section

Water is distributed through a corrosion resistant polyvinyl chloride (PVC) spray distribution system. The drift eliminators are made of PVC, which requires no protection against rot, decay, rust, or biological attack.

The inspection procedure is as follows:

- Shut off the fan and lock out and tag out the fan and pump motors.
- Remove drift eliminators to allow a clear view of the spray distribution system and nozzle patterns.
- Start the recirculating pump. Make sure the fan motor is locked out and tagged out. Check to see if the nozzles are all spraying consistently and producing the spray pattern shown in **Figure 7**.
- Clean any nozzles that are clogged. If necessary, the nozzle and rubber grommet may be removed for cleaning. If additional cleaning is necessary the branch may be removed for cleaning. With the BranchLok™ System, tools are not required to remove the branches.
- Inspect the coil surface. Any corrosion, damage, or obstructions must be corrected.
- The coil is designed for seasonal dry operation followed by seasonal wet operation, and not for frequent cycling of the spray pump. Frequent spray pump cycling may lead to excessive scale buildup.

With electrical heater tape, heat trace and insulate all exposed water piping, including pump piping below the overflow level and make-up water lines.

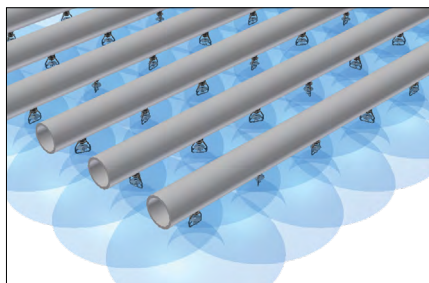

Figure 7. Nozzle Spray Pattern



Detailed Component Maintenance Procedures

BALTDRIVE® Power Train

Fan Motor Inspection & Maintenance

Fan Shaft Bearing Inspection & Maintenance

Water Distribution and Heat Transfer Section

CAUTION: Do not use the plastic drift eliminators as a walking, working, or storage surface. Stepping on or placing weight on an eliminator can result in physical injury and/or equipment damage. After ensuring that the fan and pump motors are locked and tagged out, lift and remove eliminators as necessary to perform recommended maintenance and inspections. If access to the top of the coil is required, place a piece of plywood at least 1/2 inch thick on top of the coil to protect the surface while performing the recommended maintenance. When finished, carefully remove the plywood and re-install any eliminators which were removed.



NOTICE: Do not use steam or high pressure water to clean PVC eliminators, fill or materials other than steel.

Water Level Control

There are two types of water level controls used on Vertex™ Evaporative Condensers:

- Mechanical make-up valve assembly
- Optional electric water level control package

Mechanical Make-up Valve Assembly

A float-operated mechanical water make-up assembly is furnished as standard equipment on the unit. The standard make-up assembly consists of a corrosion resistant make-up valve connected to a float arm assembly actuated by a polystyrene-filled plastic float. The float is mounted on an all-thread rod held in place by wing nuts. The basin operating water level can be adjusted by repositioning the float and all-thread rod using the wing nuts provided.

- Inspect the make-up valve assembly monthly and adjust if necessary.
- Inspect the valve annually for leakage. Replace the valve seat if necessary.
- Maintain the make-up water supply pressure between 15 psig and 50 psig for proper operation. BAC recommends a pressure regulator valve (provided by others) for pressures over 50 psig.
- Set the initial basin water level by adjusting the wing nuts so that the make-up valve is completely closed when the water level in the basin is at the operating level as stated in **Table 1** on **page 10**.
- With the design thermal load and the average water pressure (15 to 50 psig) at the valve, the above setting will produce operating water levels as stated in **Table 1** on **page 10**.
- If the thermal load is less than the design load at the time of unit start-up, the procedure may produce operating levels greater than those shown in **Table 1**. If operating levels are higher than specified, readjust the float in order to attain the recommended operating level.
- Closely monitor the water level in the basin and adjust the level if necessary during the first 24 hours of operation.
- Operating at the recommended water level will ensure that the unit basin contains sufficient water volume to prevent air entrainment in the circulating pump during system start-up and provides sufficient excess basin capacity to accept the total system pull-down volume.

NOTE: If the unit has been ordered with the optional electric water level control package or is intended for remote sump application, a mechanical water make-up valve will not be provided.



Optional Electric Water Level Control Package

As an option, an electric water level control package is available in lieu of the mechanical make-up assembly. The package consists of a probe-type liquid level control assembly and a slow-closing solenoid valve. Stainless steel electrodes, factory-set at predetermined lengths, extend from an electrode holder into the basin. For more information, refer to the *Electric Water Level Control Operation & Maintenance Manual* available at www.BaltimoreAircoil.com.

- Clean the stainless steel electrodes periodically to prevent accumulations of scale, corrosion, sludge, or biological growth, which could interfere with the electrical circuit.
- The water level is maintained at the recommended operating level regardless of the system thermal load. Therefore, it is not recommended that the operating level be adjusted.
- During the start-up of units equipped with the electric water level control package, bypass the control unit in order to fill the unit to the overflow connection.

L.E.D. Status Codes

- **L.E.D. on steady:** Indicates normal operation.
- **Steady one second flashing:** Indicates dirty probes, reading in the capacitance mode. The unit will still operate but will give the following status code of 1 second on, 1 second off (steady 1 second flashing). This status code continue until the probes are cleaned and the power has been reset. Note: No other status codes will be displayed until the dirty probes are cleaned.
- **Two flashes and off for 5 seconds:** Indicates make-up valve ran for more than 1 hour. The unit will continue to fill, with the following status code of 1 second on, 1 second off, 1 second on and then off for 5 seconds before repeating. This status will continue until power has been reset. *Possible causes:* leaking tank, obstructed fill / defective valve or reduced flow rate.
- **Three flashes and off for 5 seconds:** Indicates shorted probes or highly conductive water. The unit will continue to operate but will give the following status code of 1 second on, 1 second off, 1 second on, 1 second off, 1 second on and then off for 5 seconds before repeating. This status will continue until the water is diluted or the short is removed from the probes and power is reset.
- **Four flashes and off for 5 seconds:** Indicates black probe (P6) reads covered, but white probe (P5) does not read covered (white should also be covered because it is longer than the black). This will cause the fill solenoid valve to short cycle and lead to premature failure of the fill valve. The unit will short cycle and give the status code of 1 second on, 1 second off, 1 second on, 1 second off, 1 second on, 1 second off, 1 second on and then off for 5 seconds before repeating. The unit will continue to short cycle until the condition has been corrected (clean white probe) and the power reset.
- **L.E.D. does not come on after power up or resetting power:** Indicates unit inoperative.



Detailed Component Maintenance Procedures

Water Level Control

Mechanical Make-up Valve Assembly

Optional Electric Water Level Control Package

3

VERTEX™ EVAPORATIVE CONDENSER

Corrosion Protection

BAC products are constructed of corrosion-resistant materials. Other materials listed below are used in the equipment construction:

- **Galvanized Steel Components:** Inspect the galvanized steel components for blemishes or corrosion. Wire brush and recoat the affected areas with a cold galvanizing compound such as zinc rich compound (ZRC).
- **Thermosetting Hybrid Polymer Components:** Galvanized steel components protected with the thermosetting hybrid polymer can be scratched, scraped, or blemished. To touch up these areas use a repair kit (BAC Part # 160133) available from your local BAC Representative.
- **Stainless Steel Components:** Inspect stainless steel components for signs of blemishes or corrosion. See “Long Term Care of Stainless Steel” on **page 21** for cleaning and care instructions.
- **TriArmor® Corrosion Protection System:** Inspect components protected with the TriArmor® Corrosion Protection System for signs of deep scratches or blemishes, especially in areas with field penetrations. Touch these up with 3M™ Windo-Weld™ Super Fast Urethane which is available through your local BAC Representative (BAC Part # RK1015).

NOTE: Since the quality of the ambient air and make-up water varies significantly from job site to job site, BAC strongly recommends obtaining the services of a qualified water treatment specialist prior to the initial start-up of the evaporative cooling equipment. Additionally, to protect against the risk of Legionella contamination, never operate the cooling equipment without adequate biological control.



Water Treatment

A proper water treatment program, administered under the supervision of a competent water treatment specialist, is an essential part of routine maintenance to ensure the safe operation and longevity of evaporative cooling equipment, as well as other system components.

In evaporative cooling products, cooling is accomplished by evaporating a small portion of the recirculating water as it flows through the unit. As the water evaporates, the dissolved solids originally present in the water remain behind and if not controlled, the concentration of dissolved solids will increase rapidly. This can lead to corrosion, scale or biological fouling which may negatively affect heat transfer as well as the longevity of system components.

- **Corrosion** – Red rust on steel components and white rust on galvanized surfaces may affect the longevity of system components.
- **Scale Formation** – Scale, typically a calcium or magnesium based build-up, not only reduces heat transfer and system efficiency, but also may lead to under deposit corrosion. If scale is not controlled, it may continue building on critical components such as the fill and severely impact thermal performance.
- **Biological Fouling** – Slime and algae formations may reduce heat transfer, promote corrosion, and harbor pathogens such as Legionella.



Water Treatment

Corrosion and Scale Control

Gray Water and Reclaimed Water

- To control corrosion and scale, maintain the water chemistry of the recirculating water within the parameters listed in **Table 2**. The specific measures required vary from system to system and are dependent on the chemistry of the make-up water, the metallurgy of the piping and heat transfer devices exposed to the recirculating water, and the temperatures at which the system will be operating.
- Bleed/blowdown, the continuous flow of a small portion of the recirculating water to a drain, is used to control the concentration of dissolved solids. On rare occasions, this may be adequate to control scale and corrosion. More often, chemical scale and corrosion inhibitors are necessary, which raise the allowable level of dissolved solids without the risk of scale and corrosion.
- Keep the chemically treated water within the guidelines given in **Table 2**. In cases where bleed/blowdown alone is being employed for corrosion and scale control without chemical treatment your water treatment specialist may recommend more conservative limits than those shown in **Table 2**.



NOTES:

- Galvanized steel units require passivation in order to prevent white rust (refer to "Passivation").
- Hardness and alkalinity limits may be exceeded under certain circumstances. Consult your water treatment specialist for recommendations.
- The conversion factor used to determine conductivity is 0.625 (TDS = 0.625 x Conductivity).
- EVERTOUGH™ Construction units have a TriArmor® Corrosion Protection System basin.
- The guidelines above refer to the materials used in construction. Different combinations of materials may be used on the same unit.
- Water chemistry will change with operating temperatures. The recommended guidelines listed in **Table 2** refers to water temperature at 95°F.

Recommended Levels for Various Materials of Construction

Property of Water	Recommended Levels for Various Materials of Construction			
	Galvanized Steel	Thermosetting Hybrid Polymer	Type 304 Stainless Steel	TriArmor® Corrosion Protection System or Type 316 Stainless Steel
pH	6.5 to 9.0 ^[1]	6.5 to 9.2 ^[1]	6.5 to 9.2 ^[1]	6.5 to 9.5 ^[1]
Total Suspended Solids	25 ppm	25 ppm	25 ppm	25 ppm
Total Dissolved Solids (TDS)	1,500 ppm	2,050 ppm	2,050 ppm	2,500 ppm
Conductivity	2,400 (micromhos/cm)	3,300 (micromhos/cm)	3,300 (micromhos/cm)	4,000 (micromhos/cm)
Alkalinity as CaCO ₃	500 ppm ^[2]	600 ppm ^[2]	600 ppm ^[2]	600 ppm ^[2]
Calcium Hardness as CaCO ₃	50 to 600 ppm ^[2]	50 to 750 ppm ^[2]	50 to 750 ppm ^[2]	50 to 750 ppm ^[2]
Chlorides (CL)	250 ppm	300 ppm	300 ppm	750 ppm
Sulfates	250 ppm	350 ppm	350 ppm	750 ppm
Silica	150 ppm	150 ppm	150 ppm	150 ppm

Table 2. Quality Guidelines for Treated Circulated Water

Gray Water and Reclaimed Water

The use of water reclaimed from another process as a source of makeup water for evaporative cooling equipment can be considered as long as the resultant recirculating water chemistry conforms to the parameters noted in **Table 2**. It should be noted that using water reclaimed from other processes may increase the potential of corrosion, microbiological fouling, or scale formation. Gray water or reclaimed water should be avoided unless all the associated risks are understood and documented as part of the site specific treatment plan.

Chemical Treatment Requirements

Chemical treatment programs must meet the following requirements:

- The chemicals must be compatible with the unit materials of construction as well as other materials used in the system (pipe, heat exchanger, etc.).
- BAC discourages acid dosing as means of scale control except for open circuit cooling towers with remote sump applications or towers constructed from stainless steel. This should be done at a point in the system where total mixing and dilution occur before reaching the evaporative cooling equipment. The preferred injection point for chemical scale and corrosion inhibitors is on the discharge side of the system circulating pump(s). These chemicals should not be batch fed directly into the unit's basin or water distribution system, as this can severely damage areas directly contacted.
- When chlorine is added to the system, free residual chlorine should not exceed 1 ppm, except as noted in start-up and shutdown section on **Page 5**. Exceeding this limit may accelerate corrosion.

Passivation



NOTE: Stainless steel basins and basins protected by the TriArmor® Corrosion Protection System or thermosetting hybrid polymer do not require passivation. However, if the upper structure is galvanized steel, passivation is required on the galvanized area including any Hot Dip Galvanized After Fabrication (HDGAF) coil(s).

When new systems are first commissioned, special measures should be taken to ensure that galvanized steel surfaces are properly passivated to provide maximum protection from corrosion. Passivation is the formation of a protective, passive, oxide layer on galvanized steel surfaces. To ensure the galvanized steel surfaces are passivated, the pH of circulating water should be kept between 6.5 and 8.2 and calcium hardness between 50 and 600 ppm (as CaCO₃) for four to eight weeks after start-up, or until new zinc surfaces turn dull gray in color. If white deposits form on galvanized steel surfaces after the pH is returned to normal service levels, it may be necessary to repeat the passivation process. In case the pH can't be kept below 8.2, a secondary approach is to conduct a chemical passivation using inorganic phosphate or film-forming passivation agents. Consult your water treatment specialist for specific recommendation.

Biological Control



NOTE: ASHRAE Guideline 12: Minimizing the Risk of Legionellosis Associated with Building Water Systems is available for free from www.BaltimoreAircoil.com.

- The warm, oxygen and nutrient rich environment inside evaporative cooling equipment provides an ideal environment conducive to the growth of algae, slime, and other micro-organisms. Uncontrolled, this can reduce heat transfer, promote corrosion, and promote the growth of potentially harmful organisms such as Legionella.
- **To avoid biological contamination and minimize the risk of Legionella, initiate the biocide treatment program at start-up and continue on a regular basis thereafter in accordance with the treatment supplier's instructions.**



Corrosion Protection

Chemical Treatment Requirements

Passivation

Biological Control

Long Term Care of Stainless Steel

BAC's Manufacturing Process

Recommended Cleaning Procedure

- Bleed/blowdown or chemical treatment used for corrosion and scale control alone is not adequate for control of biological contamination.
- Introduce solid or granular biocides through a chemical “pot” feeder installed in parallel with the system circulating pump. Diluted liquid biocides may be added directly to the basin.

Long Term Care of Stainless Steel

When the percentage of chromium in steel exceeds 10.5%, it is called stainless steel. The chromium in the steel reacts with the oxygen in the air to form a chromium-oxide surface layer, also called the passivation layer that provides the corrosion resistance in stainless steel.

BAC's Manufacturing Process

BAC takes precautions to prevent cross-contamination, processing galvanized and stainless steel parts separately. Also, stainless steel brushes are used to clean welds on stainless parts and care is taken to avoid scratching parts during processing. Organic cleaners are used to clean the finished product prior to shipping.

Jobsite Considerations

While stainless steel itself does not rust so long as the chromium-oxide surface layer is intact, it is not immune to contamination from its surroundings. Some common sources of surface contamination are:

- Dirt and soil
- Shop oil or grease that may carry other contaminants such as metal chips
- Machining or welding galvanized steel at the jobsite may cause debris to impinge itself into the stainless steel

These contaminants can deposit on the surface and scratch the passivation layer or prevent it from re-forming. They can also get trapped underneath the passivation layer and reduce corrosion resistance.

Recommended Cleaning Procedure

Stainless steel needs to be cleaned regularly to maintain the corrosion resistance as well as to maintain the overall aesthetics of the stainless steel.

It is fairly simple to clean most contaminants off the surface of stainless steel. Most dirt and soil can be cleaned with a clean cloth, warm water, and mild detergent. For persistent dirt, a little vinegar can be added in the cleaning water. It is important to always rinse the surface with warm water and wipe with a dry cloth after any cleaning, whether mild or aggressive.

- Fingerprints, mild stains or grease spots can be cleaned using organic solvents such as acetone, methyl or ethyl alcohol, or mineral spirits. Stainless steel wipes or glass cleaners commonly available in stores may also be used.



NOTICE: Never use chloride or chlorine based solvents such as bleach or muriatic (hydrochloric) acid to clean stainless steel. It is important to rinse the surface with warm water and wipe with a dry cloth after cleaning.

NOTE: Long term care of stainless steel information reprinted with permission from “The Care and Cleaning of Stainless Steel”; Specialty Steel Industry of North America; <http://www.ssina.com>.



- Occasionally the surface of stainless steel can get iron chips or shavings embedded in it from having galvanized steel machined or welded in the vicinity. The iron chips can start to rust, reducing the corrosion resistance of the stainless steel, and stain the surface giving the impression that the stainless steel is rusting. These types of contaminants require more aggressive cleaning. Mild abrasives such as Scotch-Brite™ products may be used where aesthetic considerations are not important followed by solvent cleaning with organic solvents as described above. It is important to rinse the surface with warm water and wipe with a dry cloth after cleaning.
- If the iron chips are not removed with the Scotch-Brite™ Products, electro-chemical cleaning may be required. BAC uses commercially available equipment for electro-chemical cleaning in the field. Contact your local BAC Representative for more information.

System Cleaning

Coil Cleaning

The outside of the coil may require occasional cleaning. The chemicals used must be compatible with the materials being treated. For example, the standard coil outside is galvanized steel. The inside of the coil is black carbon steel. For specific recommendations on coil cleaning, contact a qualified consultant.

Weld Byproduct Cleaning

The installation and manufacturing processes commonly used for field assembly of steel-piped systems may leave weld byproducts inside coils and connecting piping (especially in refrigeration systems). It is common practice to install filters and/or strainers that remove contaminants during initial system operation. Shortly after system start-up, the filters and/or strainers should be cleaned or replaced.

Bleed Rate



In evaporative cooling, evaporation of a small portion of the recirculating spray water as it flows through the equipment causes the cooling effect. As this water evaporates, the impurities originally present remain in the recirculating water. The concentration of the dissolved solids increases over time and can reach unacceptable levels. In addition, airborne impurities are often introduced into the recirculating water. If these impurities and contaminants are not effectively controlled, they can cause scaling, corrosion, and sludge accumulations that reduce heat transfer efficiency and increase system-operating costs, potentially shortening the useful life of the equipment. The degree to which dissolved solids and other impurities build up in the recirculating water may be defined as the cycles of concentration. Specifically, cycles of concentration equal the ratio of the concentration of dissolved solids (for example - chlorides, sulfates, etc.) in the recirculating water to the concentration of the same material in the make-up water.

- In order to optimize heat transfer efficiency and maximize equipment life, bleed or blowdown a small amount of recirculating water from the system. This controls the cycles of concentration to maintain the quality of the recirculating water within the guidelines given in **Table 2**, on **page 19**.
- Replenish the “bleed” water with fresh make-up water, thereby limiting the build-up of impurities.
- Bleed/blowdown:
 - To minimize water usage, accomplish the bleed automatically through a solenoid valve controlled by a conductivity meter. The set point is the water conductivity at the desired cycles of concentration and should be determined by a water treatment expert.

Bleed Line Calculations: Bleed rate is determined by the following formula:

$$B = \frac{E}{(n-1)}$$

Where: B = Bleed Rate (USGPM)

E = Evaporation Rate (USGPM) = Q (USGPM) x R (°F) x 0.001

Q = Process Fluid Flow Rate (USGPM)

R = Range

n = Desired Number of Cycles of Concentration = CR/CM

The evaporation rate is dependent on the wet bulb temperature and load. The equation shown above provides the maximum bleed rate on the design day. Contact your local BAC representative for an exact calculation based on specific site conditions.



NOTE: A proper water treatment program, administered under the supervision of a competent water treatment specialist, is an essential part of routine maintenance to ensure the safe operation and longevity of evaporative cooling equipment, as well as other system components.



NOTE: The solenoid valve and conductivity meter must be supplied by others. Evaporation is proportional to the load and will vary seasonally. BAC recommends the use of a conductivity meter to maximize water conservation.



NOTE: The approximate design evaporation rate (E) can be determined by any one of the following methods:

- The evaporation rate is approximately 2 USGPM per 1 million BTUH of heat rejection.
- The evaporation rate is approximately 3 USGPM per 100 tons of refrigeration.
- Evaporation Rate =
 $Q \text{ (USGPM)} * R * 0.001.$



Cold Weather Operation

Inspection & Maintenance

BAC products can be operated at subfreezing ambient temperatures provided proper operating methods are established and diligently followed.

- Carry out frequent visual inspections and routine maintenance services during operation in subfreezing weather.
- Ensure all controls for capacity and freeze protection are set properly and functioning normally.
- Prevent excessively high water levels and possible overflow of the basin due to over pumping, clogged strainers, or make-up valve malfunction.
- Some unit icing can be expected in very cold weather. Usually this will not affect the operation of the unit. Resolve any icing conditions that may damage the unit or the supports, impair the system performance, or create a safety hazard.

Fan Section Icing Protection

There are three basic operational methods which can be used to provide the system's required cooling: temperature setting, fan control, and dry operation. The method of control employed on a given application depends upon the climatic extremes which are expected, the variations in heat load that will be encountered, and the compatibility of the control system with other portions of the installation.

In subfreezing ambient temperatures, effective icing control may require a combination of these three methods. Operate each unit with the highest thermal load it can handle, rather than evenly dividing the total heat load across all cells. During prolonged cold weather periods, bypass the idle units and drain the basins.

Fan Control

Reduce the unit capacity by cycling the fans, thus modulating the airflow through the unit. Rapid on-off cycles can cause induction fan motors to overheat. For induction motors, set the controls to allow a maximum of six on-off cycles per hour. EC motors will self-limit fan speed to prevent overheating. Periodically, cycle the fans off to prevent ice formation and/or to melt ice that accumulates on the equipment.

The following are fan control methods:

- **Variable Frequency Drives and EC motors:** VFDs and EC motors offer the most precise method of capacity control by modulating fan motor speed. When using them, avoid operating at or near resonant speeds. Units with VFDs require premium efficient/inverter duty motors.
- **Fan Cycling:** Cycle the fan off for five minutes every 15 to 20 minutes for each cell. If ice continues to build on the air intake, decrease the on-time. Observe the air intake of the unit at least every four to eight hours.

Dry Operation

One method to prevent icing is dry operation. Dry operation of the unit protects fans from ice formation due to mist and splash from the basin. The water in the basin must be drained in dry operation. For dry operation switch points and recommendations, contact your local BAC representative.

Basin Water and Internal Piping Freeze Protection

Basin Protection

It is important to protect the basin and internal piping. The basin water could freeze when the unit is shutdown and exposed to subfreezing ambient temperatures.

- **Remote Sump:** The ideal method of protection is a remote sump located in a heated indoor space. When the circulating pump stops, the water in the connecting piping will drain by gravity to this indoor sump.
- **Basin Heaters:** On applications without a remote sump, heat must be provided to the basin. Electrical immersion heaters can provide the required function. Contact your local BAC Representative for details.
- **Electric Water Level Control:** An electric water level control will maintain the proper water level regardless of the thermal load or variations in make-up water supply pressure. The two-position, slow closing solenoid valve provided with the BAC electric water level control package also minimizes valve freezing problems (see **page 17**).
- **Heat Tracing:** Heat trace and insulate all exposed water piping including pump piping below the overflow level and make-up water lines with electrical heater tape.



Cold Weather Operation

Inspection & Maintenance

Fan Section Icing Protection

Temperature Setting

Fan Control

Dry Operation

Basin Water and Internal Piping Freeze Protection

Basin Protection



NOTE: Modulating the water flow rate to the unit is NOT a recommended method of controlling cooling capacity.



NOTE: For remote sump applications, the water level in the basin of the equipment is a function of the design flow rate, the quantity, size and location of the remote sump connection and the pipe design between the cooling tower and the remote sump. Units installed on remote sump applications are supplied without a make-up connection.

Coil Freeze Protection

For protection against coil freeze-up, recommended solutions are an industrial grade inhibited ethylene glycol or propylene glycol solution. When the use of glycol is not practical, the system must be designed to meet both minimum flow and minimum temperature requirements.

Coil volumes for the Vertex Evaporative Condenser using liquid cooling circuits is job specific.

Minimum Operation

When utilizing an auxiliary cooling circuit with water as the cooling media, the system must be operated to meet minimum flow and temperature requirements. Maintain a minimum heat load so that the temperature of the fluid leaving the coil is not less than 50°F (10°C).

To maintain the leaving fluid temperature at 50°F (10°C) when the process load is extremely light or shut off, apply an auxiliary heat load to the circulating fluid and adjust the flow to ensure that fluid leaving the coil maintains the minimum required temperature. Otherwise, a glycol solution can be used as the cooling media to prevent freezing.

Operation Considerations for Accessories

Basin Heater (Optional)

One or more electric immersion heaters prevent the basin from completely freezing over and damaging the unit during shutdown or standby. The heaters are sized for the specific unit. The heating element has an enclosure that is suitable for outdoor use. Annually, inspect the basin heater prior to the risk of reaching freezing operating conditions.

Operation

Ensure that the heating element is completely submerged before energizing the main disconnect. For installations that have a BAC Controls Enclosure, please consult the submittal packet provided with the unit and contact your local BAC Representative for support. For installations that use a stand alone BAC heater control panel, see below.



Figure 8. Basin Heater



NOTICE: The basin heater is not designed to prevent icing during unit operation.

Stand Alone BAC Heater Control Panel (Optional)

The heater control system consists of a heater control panel and a combination temperature/water level sensor. The stainless steel sensor probe with 1/2" NPT mounting fitting has an on/off relay output that de-energizes the heaters whenever the basin water temperature is above 45°F (7.2°C), or whenever the sensor probe is not fully submerged. The control panel enclosure is suitable for outdoor use.

The control system utilizes a combination temperature/low water level control sensor, which is powered by a transformer in the control panel. When the sensor provides a signal to the control panel, the panel sends a control voltage to the magnetic contactors. When energized, the magnetic contactors supply line voltage to the heaters. Annually inspect the heater control system prior to the risk of reaching freezing operating conditions.



NOTICE: The heater control panel temperature/low level control can only be used with the supplied combination temperature/water level sensor probe. Please contact your local BAC Representative for replacement parts.

Operation

WARNING: Dangerous voltages are present in this equipment.

Disconnect the electrical service of the source and tag the circuit out before servicing or replacing components.

NOTICE: Do not operate the system unattended or for extended periods of time during test mode (resistor across terminals T1 and T2).

Operation in water temperatures above 45°F (7.2°C) could damage the unit.

NOTICE: Do not operate the system unattended or for extended periods of time with terminals G1-G2 jumpered. A low liquid level condition could occur, and the system will not shut off which could result in damage to the heater and unit.

Ensure that the element is completely submerged before energizing the main disconnect. The combination temperature/low level control is preset to energize the heater at 40°F (4.5°C), but will not energize if the water level is too low or if the water temperature is above 45°F (7.2°C).

Testing the heater when water temperatures are above 45°F (7.2°C):

- Disconnect the heater control panel and tag out the circuit.
- Remove the heater control panel cover.
- Remove the sensor wires connected to terminals T1 and T2 on the combination temperature/low level control and isolate them.
- Install the 1.5K ohm test resistor supplied with the heater control panel (in bag on outside of cover) across terminals T1 and T2.
- Install the heater control panel cover.
- Energize the system and listen for the contactor closing.
- After operation, de-energize the circuit, disconnect the heater control panel, and tag out the circuit.
- Remove the resistor and place it back in the storage bag. Check all connections, reconnect sensor wires per the wiring diagram to terminals T1 and T2, replace the cover, and place the system back in service.

Operation when the sensor probe is encased in ice:

- Disconnect the heater control panel and tag out the circuit.
- Remove the heater control panel cover.
- Install a jumper wire across terminals G1 and G2 on the combination temperature/low level control circuit board.
- Install the heater control panel cover.
- Energize the system and listen for the contactor closing.
- Operate the system until the ice is melted around the probe.
- After operation, de-energize the circuit, disconnect the heater control panel, and tag out the circuit.
- Remove the jumper, check all connections, replace the cover, and place the system back in service.

NOTE: Figure 9 is superseded by any drawing supplied with the panel by the manufacturer.

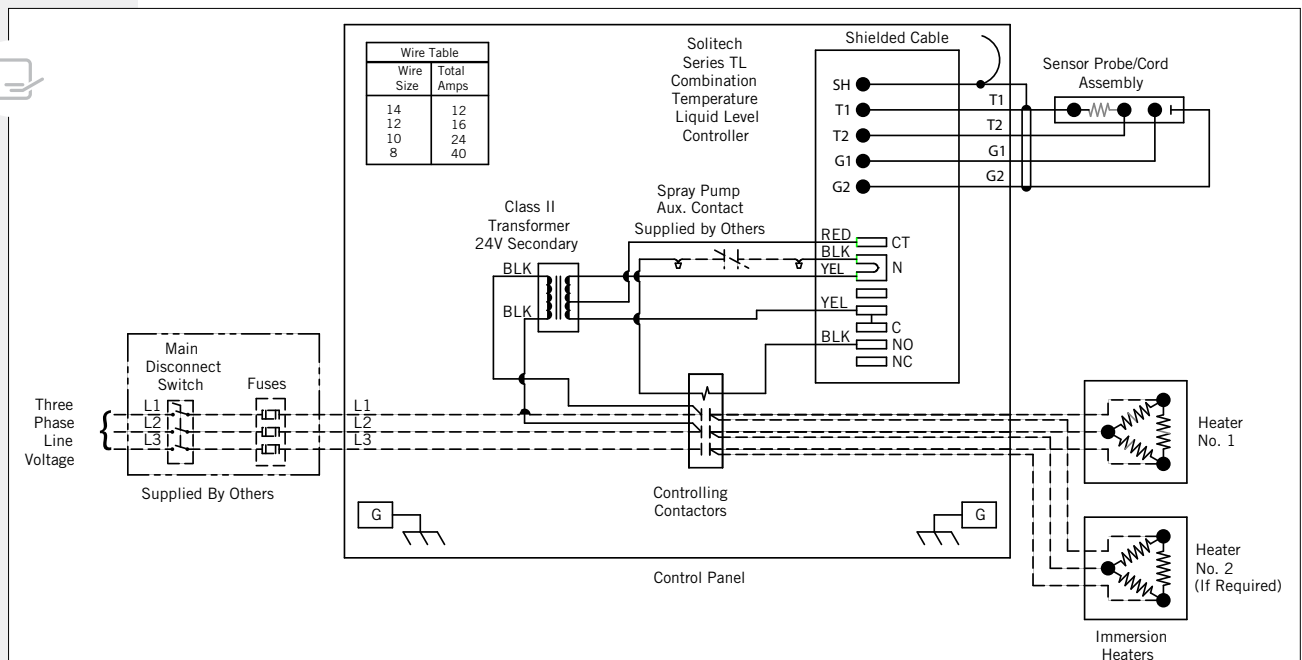

Figure 9. Example Wiring Diagram for Stand Alone BAC Heater Control Panel (Refer to Submittal Drawing for Specific Wiring Diagram)

Vibration Cutout Switch (VCOS)



Operation Considerations for Accessories

The Mechanical Vibration Cutout Switch and the Optional Electronic Vibration Cutout Switch should be tested and field adjusted at start-up and yearly thereafter. Both are located on the outside of the unit, next to the access door.

For units equipped with the EC fan drive system, vibrations are monitored by built-in sensors in the motors. A separate vibration cutout switch is not needed.

Mechanical Vibration Cutout Switch (Standard)

Set Point Adjustment When Installed:

1. For safety, turn off, then lock and tag-out the electrical supply to the fan motor(s).
2. Turn adjustment screw counterclockwise 1/8 turn at a time until you hear the control trip.
3. Once tripped, rotate adjustment screw 1/4 turn clockwise. Push in the manual reset button.
4. Start up the fans to determine if the start-up will cause the cut-out switch to trip.
5. If the VCOS does not trip, start and stop the fan two more times. If the VCOS still does not trip, then calibration is complete.
6. If the VCOS trips, follow the steps in the note to the right.

Electrical Reset and Start-up Lockout (Optional):

1. If rated voltage is continuously applied to the reset circuit at unit start-up, the reset solenoid energizes for a fixed time interval (approximately 30 sec), after which time the solenoid is automatically de-energized by the thermistor. This provides a trip lockout during machine start-up roughness.
2. The voltage must be removed from the reset circuit when the machine is stopped to allow the thermistor to cool off.
3. The switch mechanism can be reset electrically by a momentary application of the reset voltage or it can be reset manually.

Electronic Vibration Cutout Switch (Optional)

Two models of electronic vibration cutout switches are available. The single set point model contains one trip limit for shutdown. The dual set point model contains two independent trip limits; one for alarm and one for shutdown. The shutdown set-point is factory set at 0.45 in/sec. Additional details can be found in the submittal packet.

WARNING: Before performing an adjustment or inspection of the VCOS, make certain that all power has been disconnected and locked in the off position. Moisture inside the switch can lead to switch failure. Care must be taken when replacing the cover on the vibration switch to ensure that the proper watertight seal is obtained.

Testing:

- The test position sets in the minimum set point so that any vibration will cause a trip condition.
- The light will come on immediately, and the trip will occur after the duration of the time delay, proving the complete system is operational.
- If test position is maintained for less than the duration of the time delay, the trip will not occur, thus permitting the system test without shutdown.

Calibration:

- A light adjacent to the set point control comes on the instant the measured vibration level exceeds the set point.
- The unit can be periodically calibrated on line by turning the set point control down until the light comes on. This setting is then compared with the vibration measured with a portable vibration meter, thus providing a calibration check of the unit.
- If the trip setting is maintained, trip will occur after the duration of the time delay.

Remote Reset: Connection of between terminals 6 and 7 latches electromechanical relay output in alarm state after set point is exceeded. Opening the connection will reset the output to non-alarm state.

Stand Alone BAC Heater Control Panel

Operation

Vibration Cutout Switch (VCOS)

Mechanical Vibration Cutout Switch
Electronic Vibration Cutout Switch

NOTE: If the VCOS trips, turn off, then lock and tag out the electrical supply to the fan motor(s). Adjust the set point screw an additional 1/4 turn clockwise, and push in the manual reset button. Start up the fan motor(s) to determine if the start-up will cause the VCOS to trip. Repeat this adjustment process until the VCOS no longer trips when the unit is operated. Make sure to lock out and tag out the electrical supply to the fan motor(s) before entering the unit or re-setting the switch, each time an adjustment to the VCOS is made. After the final adjustment has been made, start and stop the fan motor(s) two more times to ensure that the VCOS is properly set.

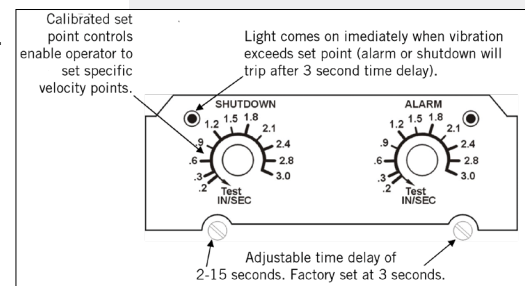

Figure 10. Electronic VCOS with Alarm Contact is Shown

Fan Control

EC Fan System Fan Control

All EC fan motors are controlled simultaneously by a single 4-20mA analog signal where 4mA is 0% speed and 20mA is 100% speed. Control signals outside of this range will cause the unit to operate in emergency mode (approx. 40% fan speed).

Sequence of Operation

Fan Ramp Sequence

Before start-up, ensure that the unit is energized and a control signal between 4 and 20mA is provided to terminals AIN and AGND. The fans will respond to an increasing speed signal, per **Figure 11**:

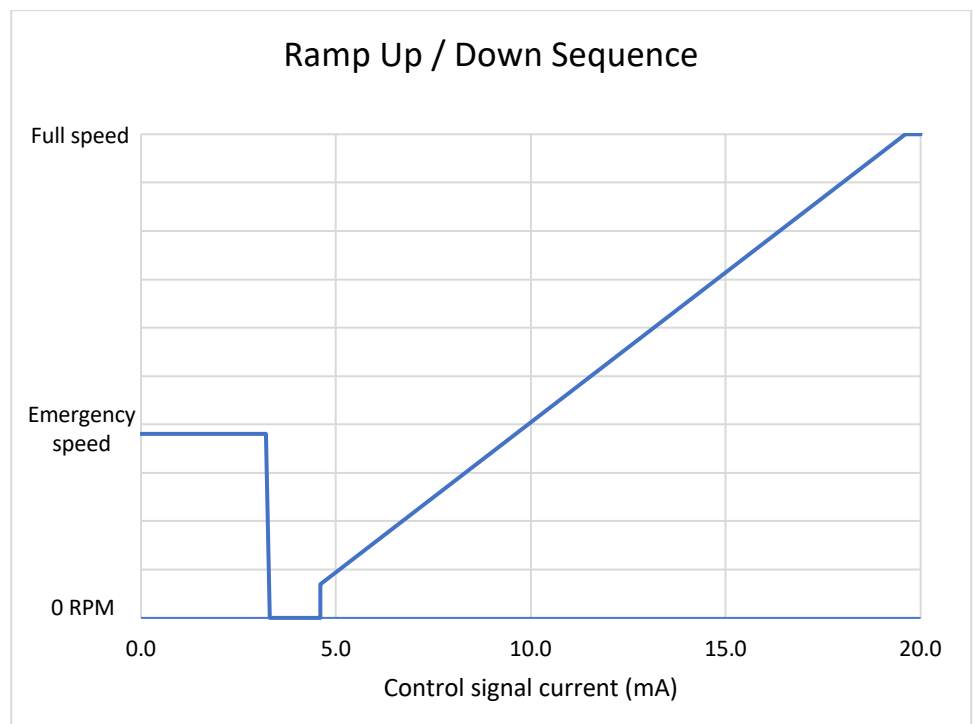

Figure 11. Ramp-up Sequence

1. If the control signal is less than or equal to 3.2mA for more than 60 seconds:
 - i. The alarm light on the control panel will turn ON and an alarm signal will be enabled.
 - ii. All fans will rotate at the emergency speed.
2. When the control signal reaches 4.6mA, the fans will initiate rotation.
3. Between 4.6mA and 20mA, the fans ramp up linearly and proportionally to the input speed signal.



Fan Control

EC Fan System Fan Control

Sequence of Operation
Vertex™ Fan Ramp-down

EC Fan System Troubleshooting

Loss of Control Signal

VERTEX™ Fan Ramp-down

The fans will respond to decreasing speed signal, per **Figure 11**:

1. Between 20mA and 4.4mA the fans ramp down linearly and proportionally to the input speed signal.
2. For control signals between 4.4 and 1.9mA, the fans will stop.
3. If the fan signal is less than 1.8mA for more than 60 seconds:
 - a. The alarm light on the control panel will turn ON and an alarm signal will be enabled.
 - b. All fans will rotate at the emergency speed.

EC Fan System Troubleshooting

Loss of Control Signal

Refrigeration System Controller Power Outages

1. When a power outage lasts for less than 60 seconds:
 - a. The fans will remain on at the last known speed.
 - b. After power restoration, the fans will resume operation according to the control signal. No alarm signal will be sent to the control system.
2. When a power outage lasts for more than 60 seconds:
 - a. The fans will rotate at the emergency speed.
 - b. An alarm light on the control panel will turn on, and an alarm signal will be enabled.

Single Fan Communication Loss

1. If the signal is restored within 60 seconds:
 - a. The affected fan will run at the last known control signal as long as the signal returns in less than 60 seconds.
 - b. The remaining fans will run according to the control signal.
2. If the signal is not restored within 60 seconds:
 - a. All fans will run at the emergency speed.
 - b. The alarm light on the control panel will turn on and an alarm signal will be enabled.
3. To troubleshoot:
 - a. Confirm that all fans are powered.
 - b. Turn the override switch on the control panel to the ON position and amber light will turn ON.

- c. All the remaining fans that are not in an alarm state will start to rotate based on the fans speed signal.
- d. If there is a problem with any individual fan that either does not rotate or rotates backwards, visually observe the fans to identify the affected fan.
- e. Shut down the unit completely, including the spray pump and breaker for the affected fan.
- f. Follow all applicable safety procedures and lockout/tagout procedures before entering the unit.
- g. Cover the affected fan with the fan cover that is included with the unit inside the lower section.
- h. Turn the unit ON by following the start-up procedure:
 - i. The unit will go into emergency mode. An alarm light on the control panel will turn ON and an alarm signal will be enabled.
 - ii. Turn the override switch on the control panel ON, and an amber light on the control panel will also turn ON.
 - iii. All fans except the affected fan will start to rotate based on the control signal.

All Fan Communication Loss

1. If the signal is restored within 60 seconds:
 - a. The unit will operate as normal, and no alarm signal will be enabled.
2. If the signal is not restored within 60 seconds:
 - a. All fans will rotate at the emergency speed.
 - b. An alarm light on the control panel will turn on and an alarm signal will be enabled.
3. To troubleshoot:
 - a. Ensure that all fans have power and that the communication signal is restored.
 - b. Turn on the override switch on the control panel, and an amber light will turn on.
 - c. All fans will start to operate based on the control signal.
4. To turn off the override light, the unit must be restarted with a valid control signal present.

Power Outage

Single Fan Power Outage

1. If power is restored within 60 seconds and an uninterrupted control signal is maintained to all fans:
 - a. The remaining fans will rotate based on the control signal except the affected fan.
 - b. After power is restored, the affected fan will resume operation based on the control signal.
 - c. No alarm signal will be enabled.
2. If power is out for more than 60 seconds:
 - a. An alarm light on the control panel will turn ON and an alarm signal will be enabled.
 - b. The remaining fans will rotate at emergency speed.
3. Troubleshooting the Issue:
 - a. Shut down the unit completely, including the spray pump and fans.
 - b. Follow all safety procedures before entering the equipment.
 - c. Cover the affected fan that is not operating with the fan cover, provided by BAC.

- d. Turn on the unit by following the start-up procedure:
 - i. The unit will go into an emergency mode. An alarm light on the control panel will turn ON and an alarm signal will be enabled.
 - ii. Turn the override switch on the control panel ON, and an amber light on the control panel will also turn ON.
 - iii. All fans except the affected fan will start to rotate based on the control signal.



Fan Control

EC Fan System Troubleshooting

- Loss of Control Signal
- Power Outage
- Fan Alarm Codes

Unit Power Outage

1. If power to the entire unit goes out, then once power is restored:
 - a. If the control signal is restored within 60 seconds of power restoration:
 - i. The unit will operate based on the control signal.
 - b. If the control signal is not restored within 60 seconds of power restoration:
 - i. The alarm light on the control panel will turn ON and an alarm signal will be enabled.
 - ii. After power is restored, all fans will rotate at the emergency speed.
2. Troubleshooting the Issue:
 - a. Make sure that a valid control signal and power are restored to the unit.
 - b. Turn the override switch on the control panel ON, and an amber light will also turn ON.
 - c. All fans will start to operate based on the control signal.
 - d. To turn off the override light, send a valid 4-20mA control signal and restart the unit.



NOTE: Figures 12 and 13 are from the Ziehl-Abegg ECblue Quick Start Guide

Fan Alarm Codes

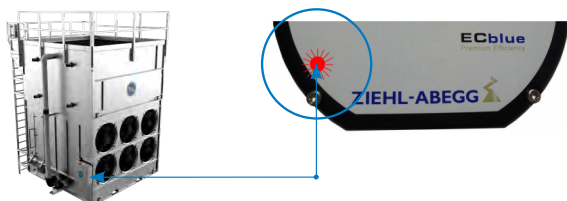

Figure 12. Flashing Light indicates Error Code

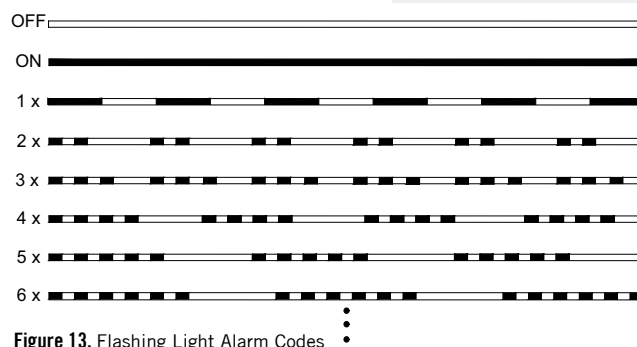

Figure 13. Flashing Light Alarm Codes

LED Code	Cause	Comments	Action
OFF	Cooling down power module	No voltage being provided to the fan motor electronics	Verify incoming power
LED Solid Red	Normal fan operation	N/A	N/A
1x	Missing run enable	Verify run enable	Add run enable or replace jumper wire
2x	Temperature management	Motor temperature management active, which temporarily decreases the maximum fan speed to prevent motor overheating	Verify that fan can rotate freely
3x	Hall effect sensor malfunction	The motor cannot determine the position of the rotor relative to the stator	Reset power to unit
4x	Phase failure	One or more phases of incoming power are lost	Verify incoming power
5x	Motor blocked	Fan blades are physically blocked	Inspect fan housing for blockage
6x	Power module failure	Controller circuitry has a short to ground or motor winding is damaged	Verify wiring to motor
7x	DC undervoltage	DC link voltage is lower than limit	Verify wiring to motor
8x	DC overvoltage	DC link voltage is higher than limit	Verify wiring to motor
9x	Cooling down power module	Motor is attempting to cool down	Verify that fan can rotate freely
11x	Error on motor start	Fan attempted to start while rotating in the opposite direction	Reset power to unit
12x	Line voltage too low	Incoming voltage is below the unit nameplate	Verify incoming power
13x	Line voltage too high	Incoming voltage is above the unit nameplate	Verify incoming power
14x	Peak current error	Fan motor is overramping	Verify that fan can rotate freely
17x	Temperature alarm	Fan motor overheated, and fans will remain off until temperature is within normal range	Verify that fan can rotate freely
20x	Modbus comm. error	Excessive vibration is occurring on fan assembly	Inspect fan

Table 3. Fan Alarm Code Descriptions

BALTIDRIVE® Power Train

- If the unit is already in operation, while the fan is running, check for any unusual noises or vibrations.
- With the fan off and the fan motor disconnected, locked out, and tagged out, check the general condition of the fan:
 - Inspect for any loose or missing bolts in the fan shaft bushing, the fan hub, and the fan shaft bearing(s).
 - Check the fan blades for looseness, first by twisting the blade by hand, and then by moving the blade tip forward and back. There should be no play or slippage.
 - Inspect each blade for excessive scale build-up that could cause vibration.
 - Check each blade for any cracks. If cracks are found, the fan motor should be locked out until the fan is replaced. Contact your local BAC Representative for assistance.
- **Tip Clearance:** Check the clearance between the tip of the blade and the fan cowl. The clearance should be between 3/16" to 1/4".

NOTE: With evaporative cooling, a 15 second fan motor delay will not be noticed when staging up.

NOTICE: For a unit with a VFD, with a switching frequency of 2.5 kHz, the line lead length cannot exceed 100 feet. If the switching frequency is higher than 2.5 kHz and/or the line lead length exceeds 100 feet, a dV/dT output filter is recommended to protect the motor. Since the switching frequency and maximum line length requirements vary between VFD and motor suppliers, contact your local BAC Representative to determine if a dV/dT filter is required.



Independent Fan Control (Optional)

Independent fan control is standard on all Vertex™ Condensers that are equipped with BALTIDRIVE® Power Train. In an operating forced draft unit with independent fan capabilities and no partitions, idle fans tend to windmill in the reverse direction. A windmilling fan poses no threat to the system while turning freely, but can create a large shock load when the fan motor is suddenly powered up. Proper staging of fans when starting from a windmilling condition will prevent excessive stresses on the drive system. There are two control strategy options:

- **VFD:** The recommended control option is to use a variable frequency drive to control all of the motors. VFDs regulate motor speed electronically and start motors with reduced voltage and frequency. The result is a gentle motor start, and therefore reduced stress.
- **No VFD**
 - **Staging Up:** Turn all motors off for 15 seconds. Following the 15 second delay, bring all required fans online. Allow for a 1 second time delay between fan stages to reduce staging current.
 - **Staging Down:** Turn off the fan motor. No need for delays.



- Applications utilizing variable frequency drives (VFDs) for fan motor control must use inverter duty motors built in compliance with NEMA standard MG-1, Part 31.
- Operation of the unit at a speed which resonates with components of the drive system or support structure may result in vibrations which could damage the components or structure, and/or create objectionable noise. Therefore, these resonant speed ranges should be identified at start-up and locked out to prevent operation of the motor at these resonant speeds. The “Resonant Speed Identification Procedure” must be conducted on **page 35**.
- Please refer to the manufacturer’s variable frequency drive recommended start-up procedure for further information or consult with your local BAC Representative for any VFD applications. For projects with BAC controls, visit www.BaltimoreAircoil.com.



NOTE: The minimum turndown ratio for units with a belt drive is 10:1 (or 6 Hz). Units with the oil pump do not have a minimum speed.

Resonant Speed Identification Procedure

There are several characteristic frequencies at which vibration levels may resonate with unit structural components. These include fan speed, motor speed, bearing frequency, and blade pass frequency. Within the overall operating speed range of a unit, it is not unusual for one or more of these characteristic frequencies to excite the structural components over relatively small speed ranges and create an increase in vibration levels. If the vibration levels are excessive at these resonant speeds, they need to be locked out to prevent the VFD from operating the motor at these speeds. The following procedure describes how to identify the lockout speed ranges:

- Ensure the VFD that controls the fan motor is off, and the power to the motor circuit is locked out.
- Attach the accelerometer (provided by others) onto the box beam as shown in **Figure 14**. The accelerometer should be placed on the top of the bearing support channel, near the fan side bearing, as shown.



NOTE: The resonant speed identification procedure must be performed at start-up for units with VFDs.



DANGER: Rotating equipment will cause severe personal injury or death to persons who come in contact. Do not perform any service on or near the fans, motors, and drives, or inside the unit without first ensuring that the fans and pump motors are disconnected, locked out, and tagged out.

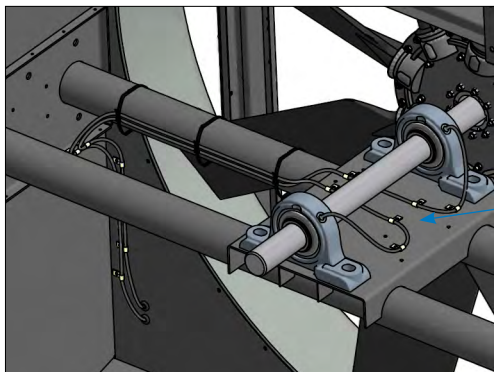

Figure 14. Accelerometer Location - Belt Drive

- Connect the signal wire from the accelerometer (provided by others) to the vibration analyzer (provided by others). Be sure to route and fasten the wire so that it will not contact any rotating parts inside the unit when the drive system is operational.
- Get out of the unit, and ensure that the drive system is “all clear”. Remove the lockout from the motor circuit.
- With the VFD off, record the vibration level indicated on the vibration analyzer, and confirm that it is very low (only picking up ambient vibration). Record this overall vibration level (0-peak) in inches per second (ips). If the ambient vibration level is greater than 0.35 ips, identify and correct the cause of the vibration. It could be vibration transmitted from another source, instrumentation malfunction, radio frequency interference, etc. If the cause is vibration transmitted from another source, and that source cannot be isolated or turned off for the duration of the measurements, note the source and magnitude of the vibration before continuing.
- After it is confirmed that the drive system is “all clear” and the unit access doors are closed, turn the VFD on, and verify that the fan is turning in the correct direction.
- Using the VFD, slowly (about 1 RPM increase every five to ten seconds) adjust the motor speed from the lowest limit to full speed while monitoring the vibration levels. Record the overall vibration levels at regular intervals if desired.
- As stated previously, when adjusting the VFD speed, proceed slowly while monitoring the vibration levels. If the vibration value approaches 0.35 ips (0-peak), slowly “zero in” on the speed where the value equals 0.35 ips, and record the speed at which this occurs as the lower end of the lockout range. Also record the vibration level at this speed.
- Continue to slowly increase the speed while monitoring the vibration level. If this is a resonance, then the value should peak and eventually decrease to a level that is below 0.35 ips as the speed is increased. After the vibration level has peaked and continues to fall, record the speed where the value equals 0.35 ips as the upper end of the lockout range.
- Using this data, a baseline for vibration history can be developed. The vibration levels can be monitored yearly and the trend used to indicate potential wear or the need to replace components in the drive system.
- After the entire speed range has been checked and any resonances identified, ensure the VFD that controls the fan motor is then turned off, and the power to the motor circuit is locked out.
- Enter the unit, and carefully remove the accelerometer, along with any associated wiring from the unit.
- Work with the VFD contractor to enter the lockout speed ranges, if any have been identified, into the VFD, so the unit will not operate at a resonant speed.
- Once it has been verified that the drive system is all clear, return the unit to its normal operating condition.
- Keep a record of any lockout speed ranges for future reference.

Installation Instructions for Field Connections

The following are installation instructions for adding new field connections (Equalizer/Bypass/Outlet) on a basin with the TriArmor® Corrosion Protection System.

Supplies Provided by BAC	Recommended Supplies Provided by Others
Template for the connection with bolt holes	Stainless steel threaded shoulder bolts
Type 304 stainless steel backing ring with gasket	150 lb flange, weld any piping to the flange prior to installation
Vulkem® Caulk	Gasket for the outside of the basin

Table 4. Supplies for Installing Field Connections

1. Use the BAC template provided with the accessory to layout and mark the hole pattern on the exterior of the basin.
2. Drill a pilot hole from the outside of the basin to the inside of the basin.
3. On the inside of the basin:
 - a. For connections 3” or less, score the TriArmor® Corrosion Protection System with a hole saw as shown in **Figure 15**.
 - b. For connections 3” or greater, proceed to step 4.
4. Cut the hole from the outside of the basin.
 - a. Use a hole saw or a step drill bit for smaller connections 3” or less as shown in **Figure 16**.
 - b. Use a reciprocating saw or a Sawzall® for larger connections 3” or greater.
5. Position the BAC supplied stainless steel backing ring gasket to the inside of the basin.
6. Position the flange to the outside of the basin.
7. Bolt the flange and the stainless steel backing plate together using stainless steel bolts.
8. Seal any exposed galvanized steel of the connection inside the basin with Vulkem® Caulk as shown in **Figure 17**.



NOTE: BAC recommends adding a flange connection for field installed equalizers, bypass and outlet connections. Please order the recommended supplies listed in **Table 4** prior to unit shutdown.



Figure 15. Scored TriArmor® Corrosion Protection System



Figure 16. Removal Material



Figure 17. Caulk Exposed Galvanized Steel

COOLING TOWERS

CLOSED CIRCUIT COOLING TOWERS

ICE THERMAL STORAGE

EVAPORATIVE CONDENSERS

HYBRID PRODUCTS

PARTS & SERVICES



www.BaltimoreAircoil.com

7600 Dorsey Run Road, Jessup, MD 20794 > Telephone: (410) 799-6200 > Fax: (410) 799-6416

© 2021 Baltimore Aircoil Company > MVRC/1-C