

DETAIL A
(ISOMETRIC)

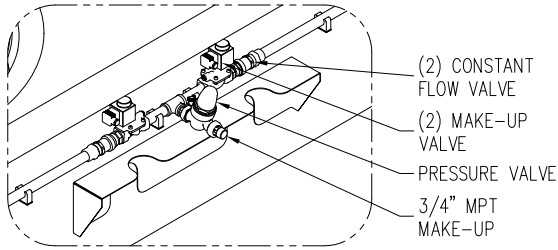

PLAN VIEW

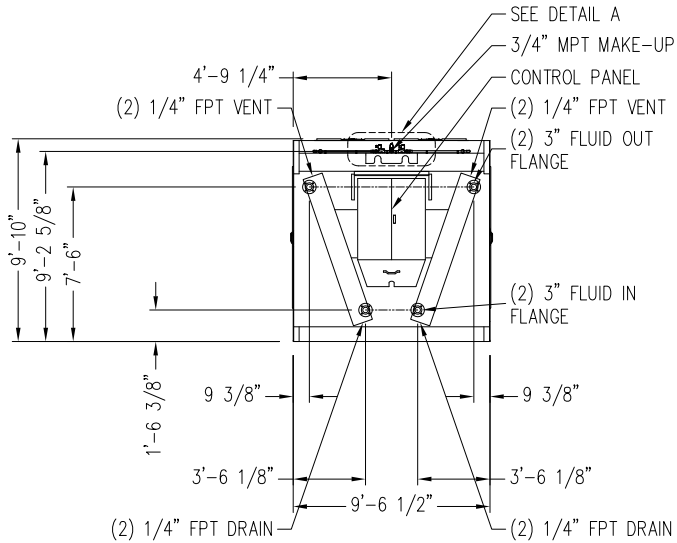
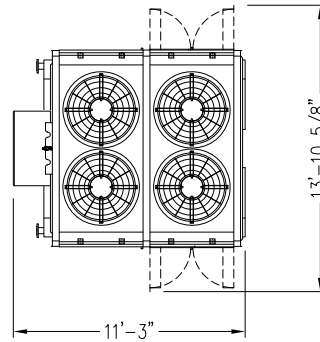

BASIN ACCESS DOORS
(BOTH SIDES)

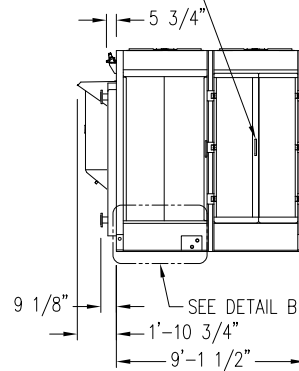

PLENUM ACCESS DOOR

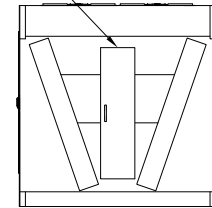

Notes

- 1) All dimensions are in feet and inches. Weights are in pounds and include options and accessories.
- 2) Dimensions showing locations of coil & basin connections are approximate and should not be used for prefabrication of connecting piping.
- 3) For weight loadings and support requirements, refer to the suggested steel support drawing.
- 4) The area above the fan discharge must not be obstructed.
- 5) Field piping must not be supported by the unit inlet or outlet connections.

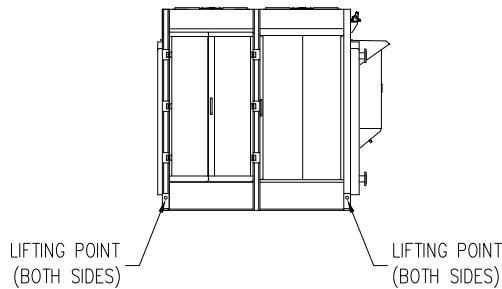

DETAIL B

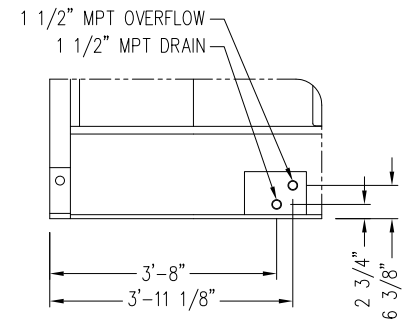

Model Number	Shipping Weight	Operating Weight	Heaviest Section
TRF-1010N-C80Gx17E	7738	9028	7738

ORDER NO:

DATE: **9/18/2023 4:40:41 PM ConfigVer=1**



BALTIMORE AIRCOIL COMPANY

**TrilliumSeries™ Adiabatic Cooler
Four Fan Unit Print**

DRAWING NUMBER: