

DETAIL A
(ISOMETRIC)

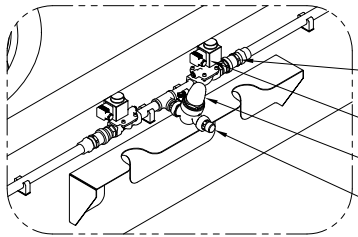

- (2) CONSTANT FLOW VALVE
- (2) MAKE-UP VALVE
- PRESSURE VALVE
- 3/4" MPT MAKE-UP

PLAN VIEW

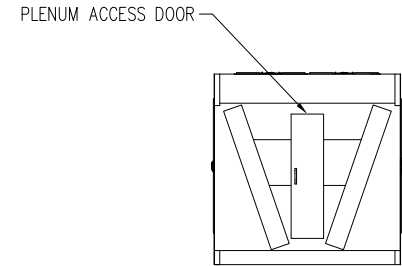
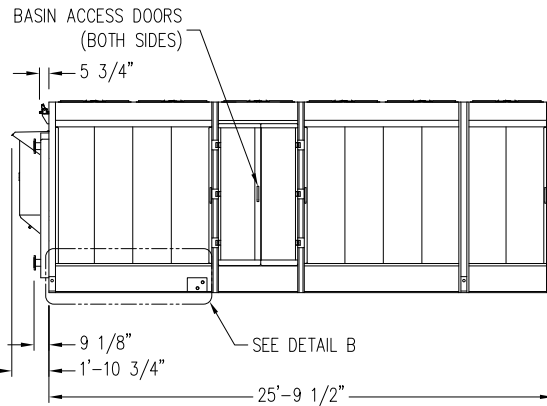
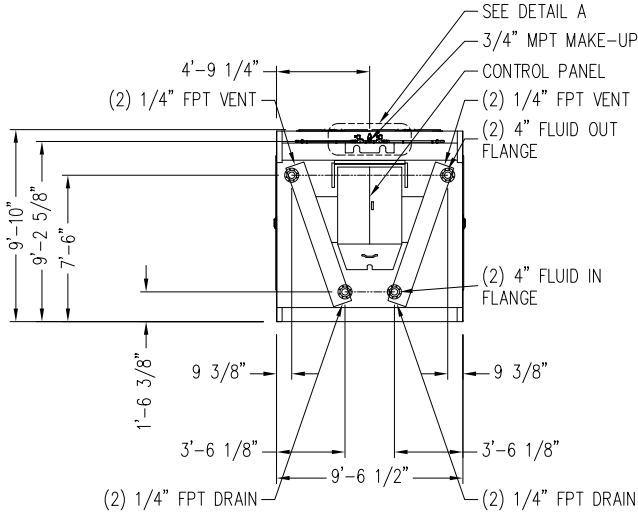
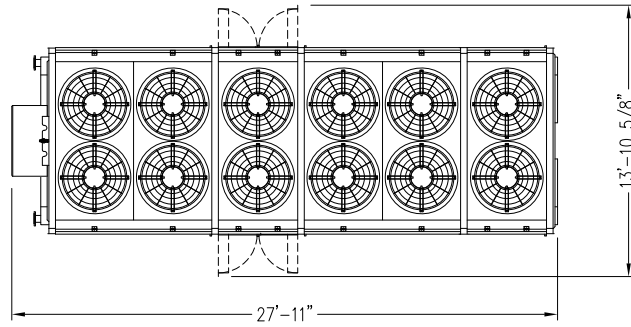

- Notes**
- 1) All dimensions are in feet and inches. Weights are in pounds and include options and accessories.
 - 2) Dimensions showing locations of coil & basin connections are approximate and should not be used for prefabrication of connecting piping.
 - 3) For weight loadings and support requirements, refer to the suggested steel support drawing.
 - 4) The area above the fan discharge must not be obstructed.
 - 5) Field piping must not be supported by the unit inlet or outlet connections.

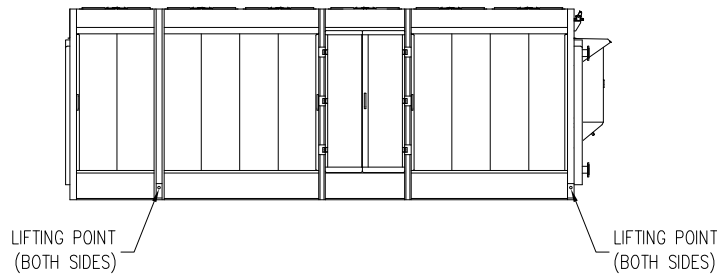

DETAIL B

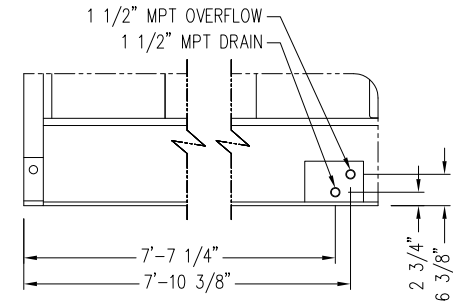

Model Number	Shipping Weight	Operating Weight	Heaviest Section
TRF-1026N-C80Gx51E	17571	21153	17571

ORDER NO:
DATE: **9/18/2023 4:35:47 PM ConfigVer=1**



TrilliumSeries™ Adiabatic Cooler
Twelve Fan Unit Print

DRAWING NUMBER: