



TrilliumSeries® Dry Cooler

Model TDFS

RIGGING & ASSEMBLY INSTRUCTIONS



IMPORTANT NOTICE

The TrilliumSeries® Dry Cooler – TDFS should be rigged and assembled as outlined in this instruction manual.

Only qualified personnel should undertake the rigging and assembly of the equipment covered by this manual.

This manual should be thoroughly reviewed prior to the actual rigging and assembly of the equipment to ensure proper procedures are followed and that all necessary equipment is available.

Proper care, procedures, and tools must be used in handling, lifting, installing, operating, maintaining, and repairing this equipment to prevent personal injury and/or property damage.

Be sure to have a copy of the equipment submittal package available for reference. If you do not have a copy of this drawing, or if you need additional information about your unit, contact your local BAC Representative, whose name and telephone number are on a label adjacent to the unit's access door. The model number and serial number of the unit are also located in this area.



TrilliumSeries® Dry Cooler - TDFS

RIGGING & ASSEMBLY INSTRUCTIONS

Contents

1. Safety Warnings.....	4
2. Introduction	6
Unit Operation	8
3. Unit Rigging & Assembly.....	9
Rigging	9
Section Assembly.....	12
Cold Weather Operation.....	14
Prolonged Outdoor Storage.....	14
4. Field Installed Components.....	16
External Platform Installation	16
External Platform Ladder Installation.....	23
Access Door Platform Installation.....	26
Access Door Platform Safety Gate.....	29
Internal Service Platform Ladder Installation	30
Internal Service Ladder Safety Gate Installation.....	33
Whisper Quiet™ Fan Installation.....	34
Fan Cowl Extension Installation for Whisper Quiet™ Fan.....	42
Fan Guard Installation	43
5. Other Installation Matters.....	45
Equipment Wiring	45
Beveled for Weld and Threaded Coil Connections.....	45
Plain Pipe Stub Coil Connections Nitrogen Charge Removal.....	45

1. Safety Warnings

⚠ DANGER Failure to use designated lifting points can result in a dropped load and cause severe personal injury, death, and/or property damage. Lifts must be performed by qualified riggers following these Rigging & Assembly Instructions and generally accepted lifting practices. The use of supplemental safety slings may also be required as determined by the qualified rigger.

⚠ DANGER Failing to properly anchor equipment before operation begins, can result in serious personal injury, death, or property damage from the movement of an unstable unit. Ensure unit is properly anchored before operation begins.

⚠ DANGER This unit has rotating fan equipment that can cause severe personal injury or death upon contact. Never step or walk on the fan guard. Always disconnect, lock out, and tag out all power sources to the fan motor(s) before performing any inspection or maintenance. Adequate safeguards (including the use of protective enclosures where necessary) should be taken with this equipment to safeguard the public from injury and to prevent property damage.

⚠ DANGER Performing work on an energized unit poses a risk of electrocution, which can cause severe personal injury, death, and/or property damage. Do not perform any service on or near the unit without first ensuring the unit is de-energized and all lockout / tagout procedures have been followed. Wait five minutes after disconnecting the voltage at all poles before opening the fan and motor assembly.

⚠ WARNING To prevent bodily injury or property damage, only qualified personnel should undertake the installation, operation, maintenance, and repair of this equipment. Proper care, procedures, and tools must be used in handling, lifting, installing, operating, maintaining, and repairing this equipment.

⚠ CAUTION Before lifting the unit, open the access hatch(es) and clear any water, snow, ice, or debris that has collected or accumulated in the unit. Such accumulations substantially add to the equipment's lifting weight and, if not cleared or otherwise accounted for, could pose a risk of severe personal injury, death, or property damage during lifting.

NOTICE Model TDFS must be rigged one section at a time to avoid damage to the unit

NOTICE If the unit is to be stored for a prolonged period before installation or remain in an unused state for a prolonged period after installation, certain precautions should be observed. Refer to Prolonged Outdoor Storage details in Section 3.

NOTICE Do not use steam, high-pressure water, or high-pressure air to clean the unit or any component to prevent equipment damage.

NOTICE Field piping must not be supported by the unit inlet or outlet connections to prevent equipment damage.

NOTICE All connections including those installed by others must be leak-free and tested accordingly.

NOTICE The installer must ensure a proper air purging of the system prior to operation. Entrained air can restrict the capacity of the cooler, resulting in higher process temperatures.

NOTICE When connecting power to the unit, do not penetrate the control panel. Doing so may allow moisture to enter the panel. All cable and conduit should be supported separately from the unit.

NOTICE Do not penetrate the unit for supports or other connections.

NOTICE Each unit must be located and positioned to prevent the introduction of discharge air into the ventilation systems of the building on which the unit is located and of adjacent buildings.

NOTICE For weight information, refer to the unit submittal drawings. Any accessories shipped in the unit must be removed prior to installation.

NOTICE Do not use power tools on the Whisper Quiet™ fan to avoid damaging mounting components and damage to the fans.

NOTICE This unit must be installed in locations not accessible to the general public.

NOTICE The pre-cooler pads are made of flammable material and should be removed when performing hot work on or near the unit. No actions that can generate sparks should be performed on or near the unit.

NOTICE To prevent excessive degradation do not attempt to remove the pre-cooler pads while wet.

2. Introduction

Safety

Adequate precautions appropriate for the installation and location of these products should be taken to safeguard the equipment and the premises from damage and the public from possible injury. **The procedures listed in this manual must be thoroughly reviewed prior to rigging and assembly. Read all warnings, cautions, and notes.**

⚠ WARNING To prevent bodily injury or property damage, only qualified personnel should undertake the installation, operation, maintenance, and repair of this equipment. Proper care, procedures, and tools must be used in handling, lifting, installing, operating, maintaining, and repairing this equipment.

Pre-Rigging Checks

⚠ DANGER Failure to use designated lifting points can result in a dropped load and cause severe injury, death, and/or property damage. Lifts must be performed by qualified riggers following these Rigging & Assembly Instructions and generally accepted lifting practices. The use of supplemental safety slings may also be required, as determined by the qualified rigger.

When the unit is delivered to the jobsite, it should be checked thoroughly to ensure all required items have been received and are free of any shipping damage prior to signing the bill of lading.

The following parts should be inspected (if applicable to the unit's configuration):

- Sheaves and Belts
- Bearings
- Bearing Supports
- Fan Motor(s)
- Fan Guard(s)
- Fan(s) and Fan Shaft(s)
- Coil Surface
- Interior Surfaces
- Exterior Surfaces
- Mating Surfaces Between Sections
- Control Panel - HMI screen, door gasket, external temperature probe
- Wiring
- Electronic Vibration Cutout Switch
- Miscellaneous Items: All bolts, nuts, washers, and sealer tape required to assemble sections or component parts are furnished by BAC and shipped with the unit

Unit Weights

Before rigging any unit, the weight of each section should be verified from the unit submittal.

⚠ CAUTION Equipment damage may occur if water, snow, ice, or debris has collected in or on the unit. Such accumulations will add substantially to the equipment's lifting weight placing equipment at risk of damage that could result in injury. Before an actual lift is undertaken, ensure no water, snow, ice, or debris has collected in or on the unit.

In the event of extended lifts or where hazards exist, the lifting devices should be used in conjunction with safety slings placed under the unit.

Anchoring

⚠ DANGER Failing to properly anchor equipment before operation begins, can result in serious personal injury, death, or property damage from the movement of an unstable unit. Ensure unit is properly anchored before operation begins.

Refer to the suggested support drawing included in the unit submittal for the location of the mounting holes.

Units have been configured to be installed on concrete or on structural steel. For project-specific configurations and anchoring details, refer to the unit submittal.

Support beams should be selected in accordance with accepted structural engineering practices. Supporting steel must be greater than or equal to the length of the unit's base, and the unit must not be point supported.

When a unit is anchored directly to concrete on grade without steel support, the support concrete must be flush and level at top. Any concrete surfaces for unit support and anchors must be in accordance with accepted structural practices.

Shipping and Removal of Shipping Protection

Model TDFS is factory-assembled to ensure uniform quality with minimum field assembly. The unit ships in two sections per cell (one lower and one upper section) to minimize rigging and freight costs. For the dimensions and weights of a specific unit or section, refer to the unit submittal drawings.

Prior to rigging or assembling of units, remove the coil shipping protection panels, including the fender washers, the plywood paneling, and the plywood backing as illustrated in **Figure 1** and **Figure 2**.

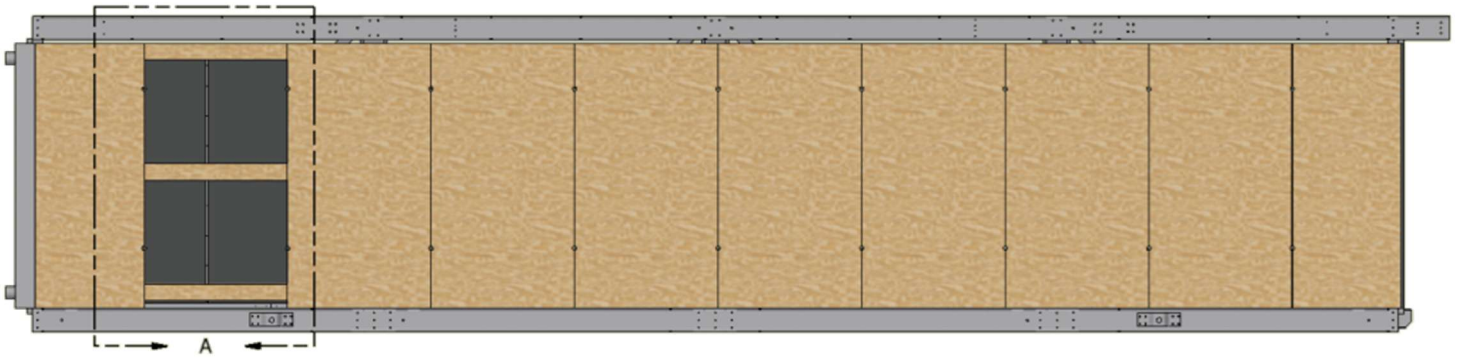

Figure 1: Removal of coil shipping protection panels

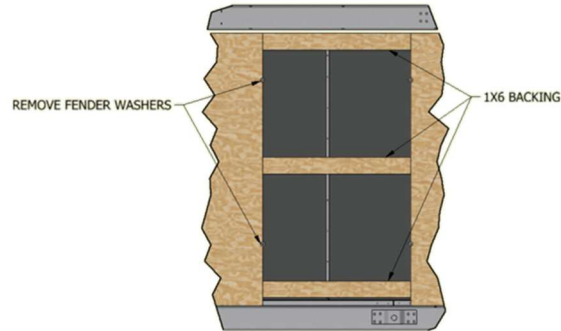

Figure 2: Detail of coil shipping protection panels

Placement and Layout Guidelines

All cooling equipment must be placed in a location that ensures an adequate supply of fresh air into the air intakes. When units are located adjacent to walls or within enclosures, care must be taken to ensure the warm, discharge air is not redirected back to the unit's air intakes. Each unit must be positioned to prevent the introduction of discharge air into the ventilation systems of the building on which the unit is located and of adjacent buildings. Refer to the [layout guidelines](#) on BAC's website for spacing requirements.

NOTICE Each unit must be located and positioned to prevent the introduction of discharge air into the ventilation systems of the building on which the unit is located and of adjacent buildings.

Unit Operation

Prior to start-up and unit operation, refer to the TrilliumSeries® Dry Cooler - TDFS Operation & Maintenance Manual.

3. Unit Rigging & Assembly

Rigging

This section details the rigging for the upper and lower sections of the unit. Refer to the unit submittal for additional information on weights and dimensions.

⚠ DANGER Failure to use designated lifting points can result in a dropped load and cause severe injury, death, and/or property damage. Lifts must be performed by qualified riggers following these Rigging & Assembly Instructions and generally accepted lifting practices. The use of supplemental safety slings may also be required, as determined by the qualified rigger.

NOTICE For weight information, refer to the submittal.

NOTICE Model TDFS must be rigged one section at a time to avoid damage to the unit.

Lower Section

A proper lifting fixture, such as an H-beam (illustrated in **Figure 3**) is strongly recommended for lifting the lower section.

Lifting should occur from the four specified internal lifting ears (see **Figure 4**). Do not lift from lower tiedowns (see **Figure 4**). See **Figure 4**, **Figure 5**, and **Figure 6** for lower section rigging information.

Refer to the unit submittal for job-specific rigging details.

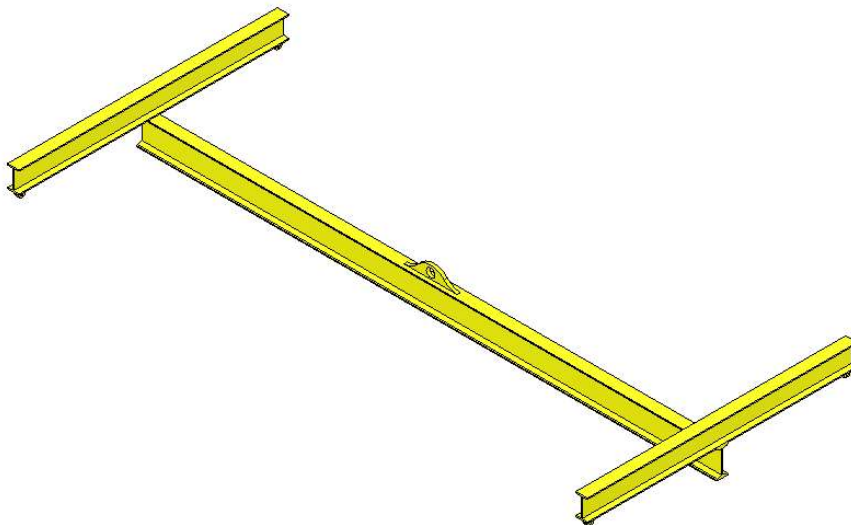

Figure 3. H-Beam Illustration

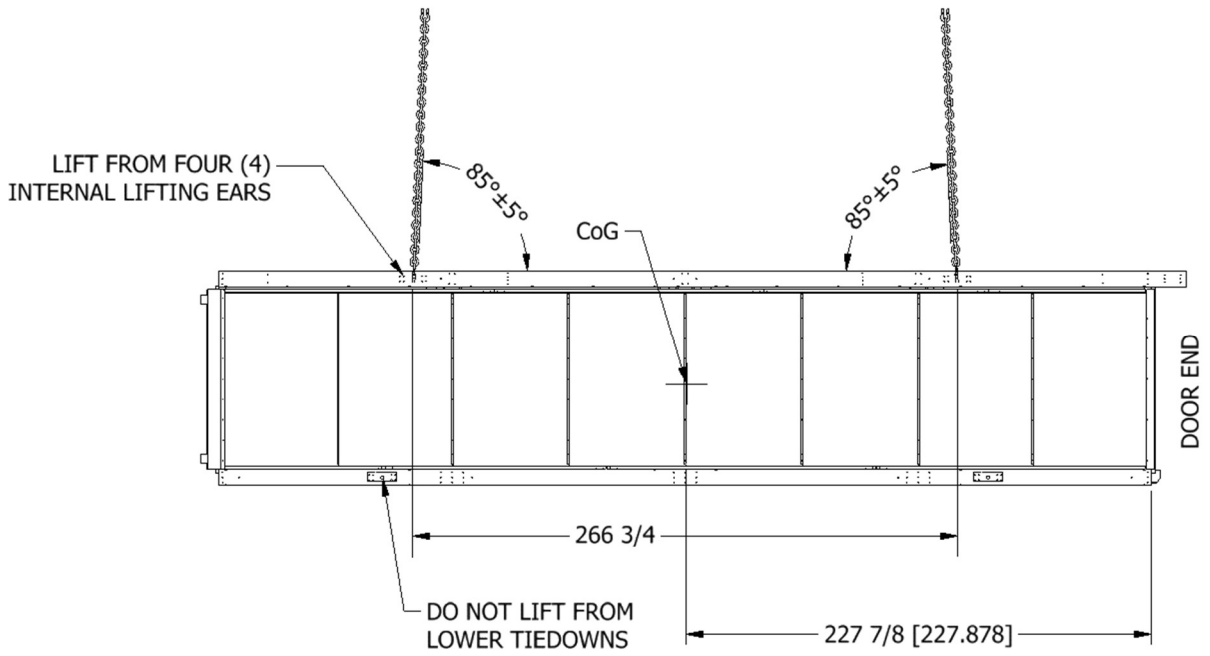

Figure 4. Lower Section Rigging Dimensions. Measurements are in inches.

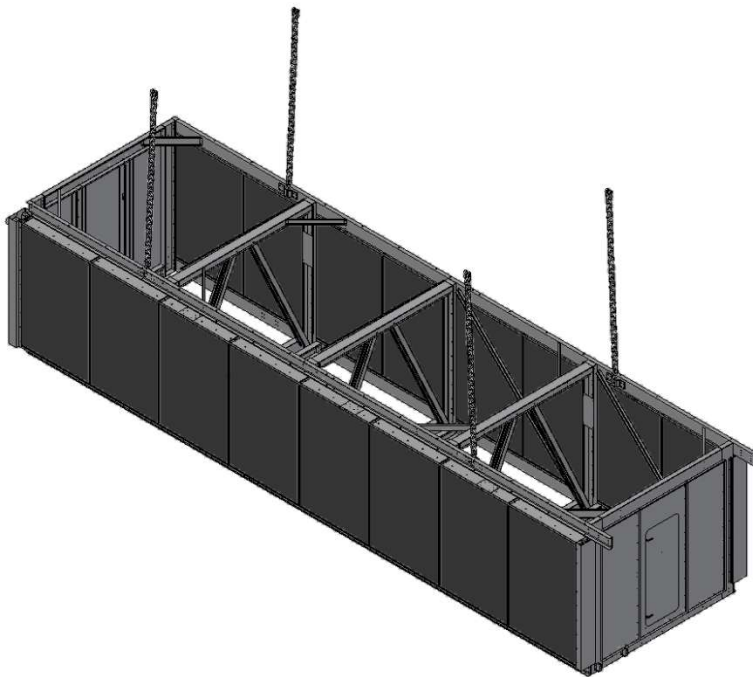

Figure 5. Lower Section Rigging

Do not lift with chains angled outward.

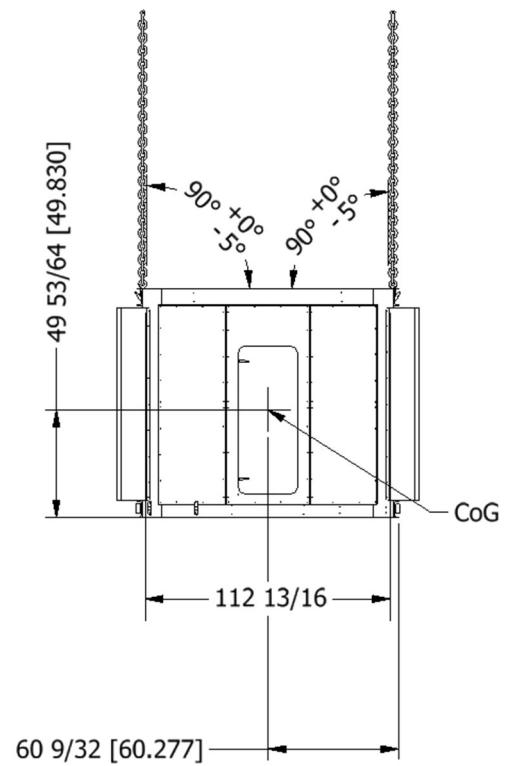

Figure 6. Lower Section Rigging Dimensions. Measurements are in inches.

Upper Section

For units with standard fans, the fans ship installed in the upper section (see **Figure 8**). For units with Whisper Quiet™ fans, the fans and cowls ship loose for field installation. A proper lifting fixture, such as an H-beam (illustrated in **Figure 3**) is strongly recommended for lifting the upper section.

The upper section should be lifted from the four specified lifting ears shown in **Figure 7**. Do not lift from lower tiedowns (also shown in **Figure 7**). Refer to **Figure 7**, **Figure 8**, and **Figure 9** for upper section rigging information. Refer to the unit submittal for job-specific rigging details.

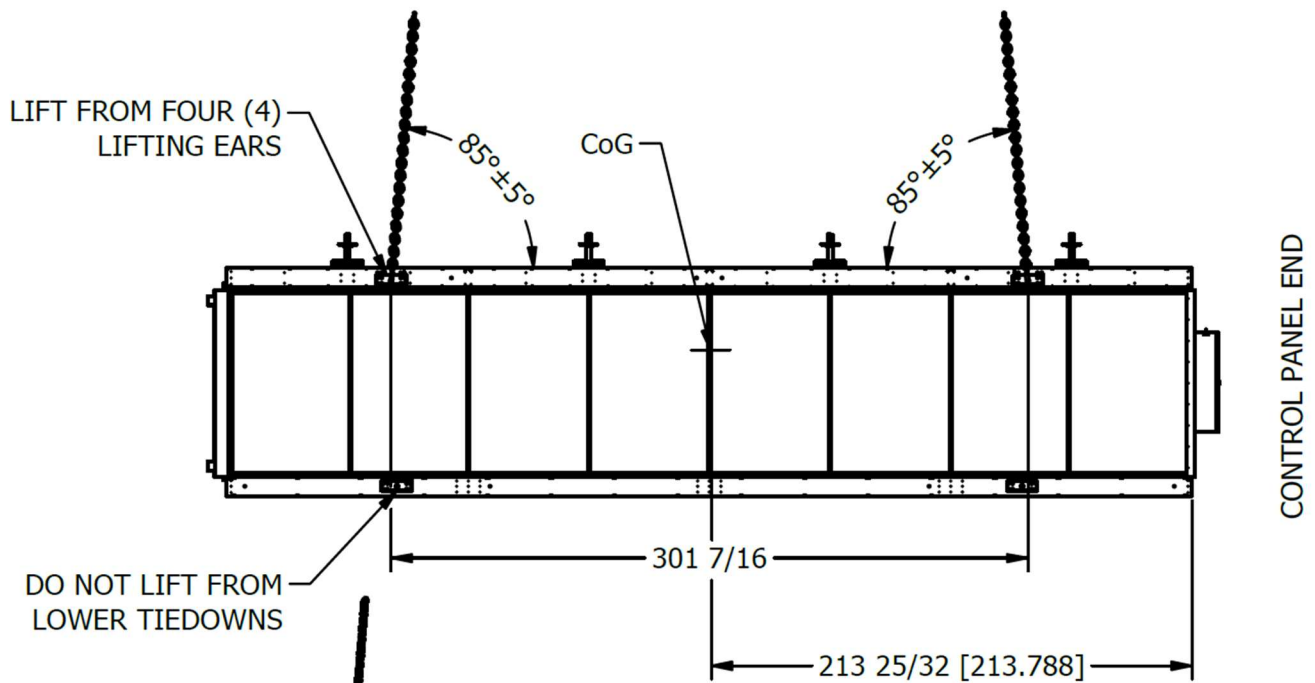

Figure 7. Upper Section Rigging Dimensions. Measurements are in inches.

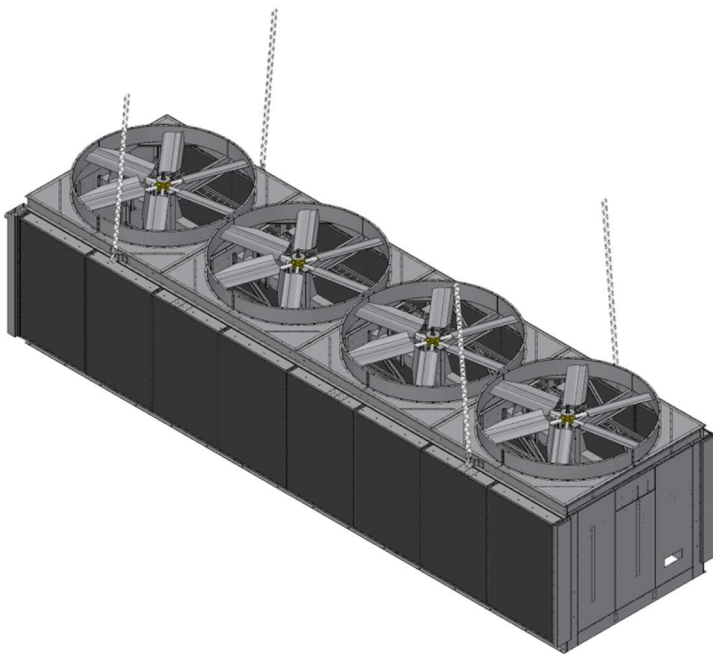

Figure 8. Upper Section Rigging

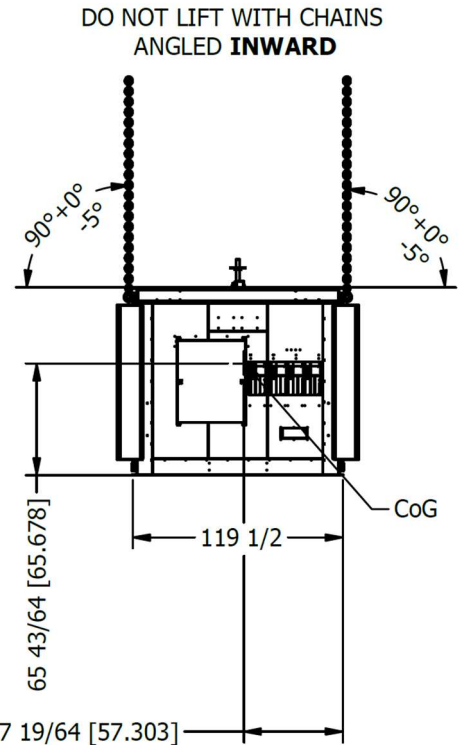

Figure 9. Upper Section Rigging Dimensions (units are inches)

Section Assembly

An illustration of the unit with the upper and lower sections in place is shown in **Figure 11**.

WARNING This section details the assembly of the upper and lower sections for proper installation. Equipment damage may occur if the unit is not properly anchored before operation begins. Equipment damage could result in death or serious injury. Ensure unit is properly anchored before operation begins.

NOTICE For weight information, refer to the submittal. Any accessories shipped in the unit must be removed prior to installation.

1. Remove any accessories shipped loose on or in the unit.
2. Position the lower section on concrete slab or unit supports and then bolt in place. If the unit is to be mounted on steel supports, bottom panels must be installed. Refer to **Anchoring** on **Page 7** and **Lower Section** on **Page 9**.
3. Wipe moisture and dirt from the C-shaped perimeter flange along the full length of the unit as shown in **Figure 10**.



Figure 10. Perimeter Flange

4. Apply flat butyl sealer tape (BAC part #554000) around the entire perimeter of the lower section.
5. Lift and set the upper section. Refer to **Upper Section** on **Page 11**.
6. Bolt the upper section in place. Refer to **Figure 11** and **Figure 12** for bolting locations and hardware type.



Figure 11. Section Assembly

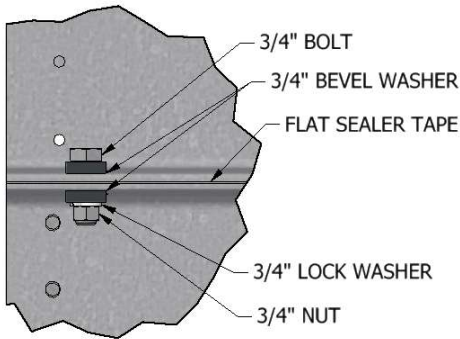

Figure 12. Detail A, Section Assembly

All Hardware to be Grade 5, Qty. 16 Per Side

Cold Weather Operation

Refer to the TrilliumSeries® Dry Cooler - TDFS Operation & Maintenance Manual.

Prolonged Outdoor Storage

The TrilliumSeries® Dry Cooler - TDFS is wrapped for shipment. If the unit is going to remain in outdoor storage for more than three months before installation, remove the stretch-wrap and tarp, and follow the storage recommendations below.

NOTICE BAC units are typically installed immediately after shipment, and many operate year-round. However, if the unit is to be stored for a prolonged period before or after installation, certain precautions should be observed.

Prolonged Storage Preparation

- Coils must be empty and closed off. For extended shutdown periods after start-up, coils should be charged with nitrogen at 15 PSIG (103 kPa) in the field and capped by adding a welded cap. Upon start-up, the coil connections will require cutting.
- Insert desiccant bags into the control panel to absorb moisture. Seal the control panel for storage.
- Inspect the protective finish on the unit. Clean as required.

Motor Storage Recommendations

TrilliumSeries® Dry Cooler motors are designed for storage at ambient temperatures of -40°F to 176°F (-40°C to 80°C). Prolonged periods of exposure above or below these temperature levels could degrade components of the motor and cause malfunction or premature failure. To protect the unit's motor:

- Care must also be taken to protect the motor from flooding or from harmful chemical vapors.
- The unit's or motor's storage area should be free from ambient vibration. Excessive vibration can cause damage.

- Keep stored motor(s) dry and protected from weather.
- Rotate the fan once per month.

Preparation After Prolonged Storage

Start-up procedures after long periods of storage are just as important as pre-shutdown procedures. Follow instructions in the TrilliumSeries® Dry Cooler - TDFS Operation & Maintenance Manual shipped with the unit and also available at BaltimoreAircoil.com. Be especially thorough with cleaning and inspection prior to start-up.

NOTICE To prevent equipment damage, do not use steam, high-pressure water, or high-pressure air to clean the unit or any component.

4. Field Installed Components

⚠ DANGER Failure to use designated lifting points can result in a dropped load and cause severe injury, death, and/or property damage. Lifts must be performed by qualified riggers following these Rigging & Assembly Instructions and generally accepted lifting practices. The use of supplemental safety slings may also be required, as determined by the qualified rigger.

External Platform Installation

This section sets forth the procedures for external platform installation. An illustration of the external platform with ladder and a safety is shown in **Figure 13**. External platform ladder and safety gate installation information appear later in this manual.

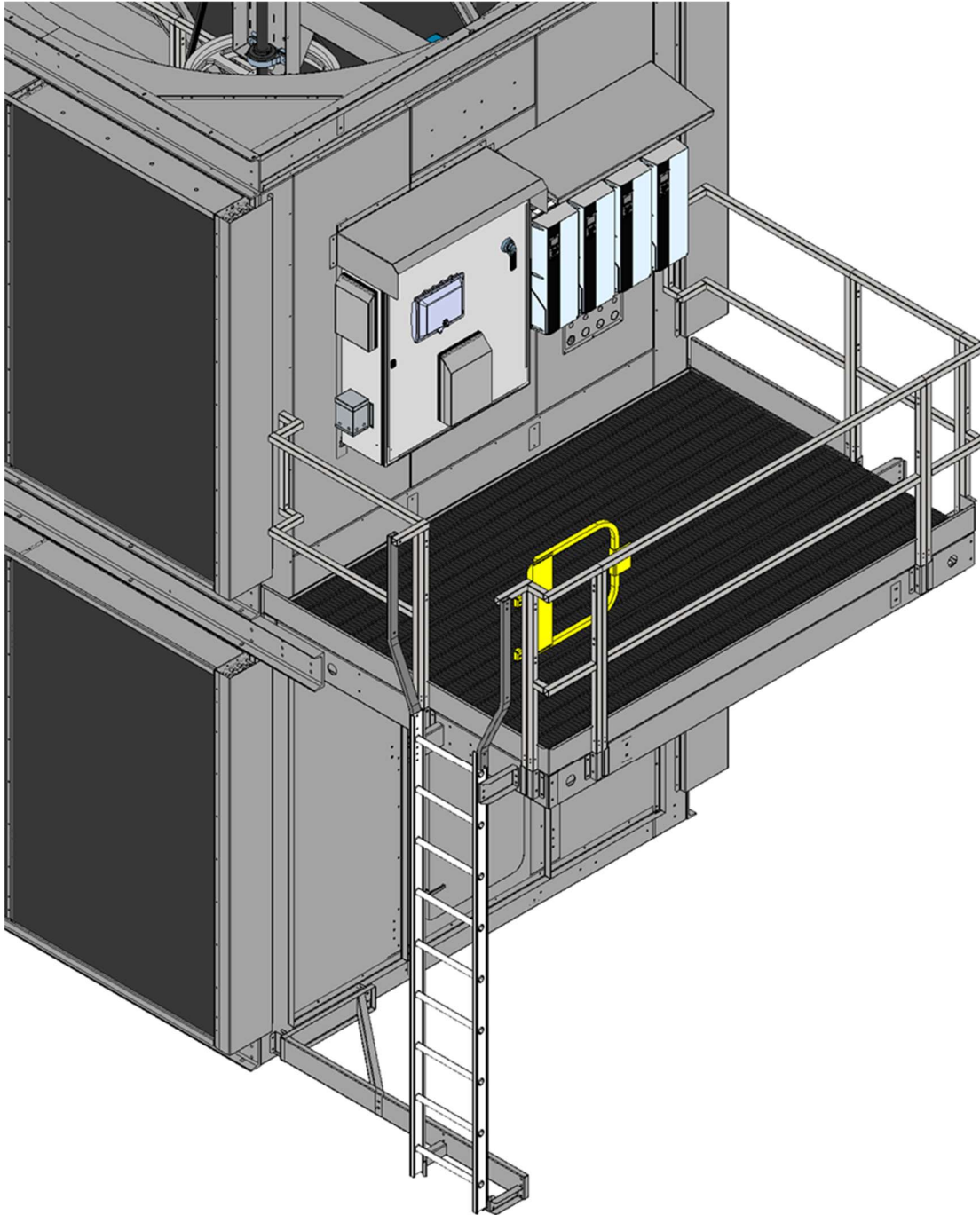

Figure 13. External Platform and Ladder

1. Starting with the factory assembled external platform shown in **Figure 14**, install the external platform railings per **Figure 15**. Circled items in **Figure 15** are paired with dimensions and correspond to railing parts specified in the submittal. Platform location is site-dependent per the submittal. Refer to

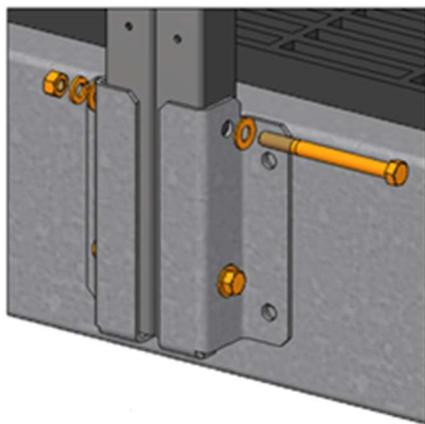
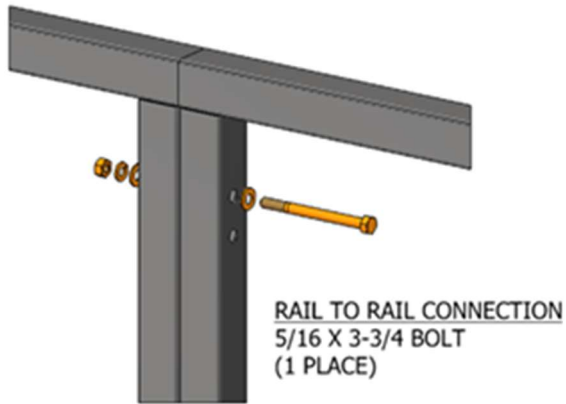

Figure 16 and

2. Figure 17 for bolting details.

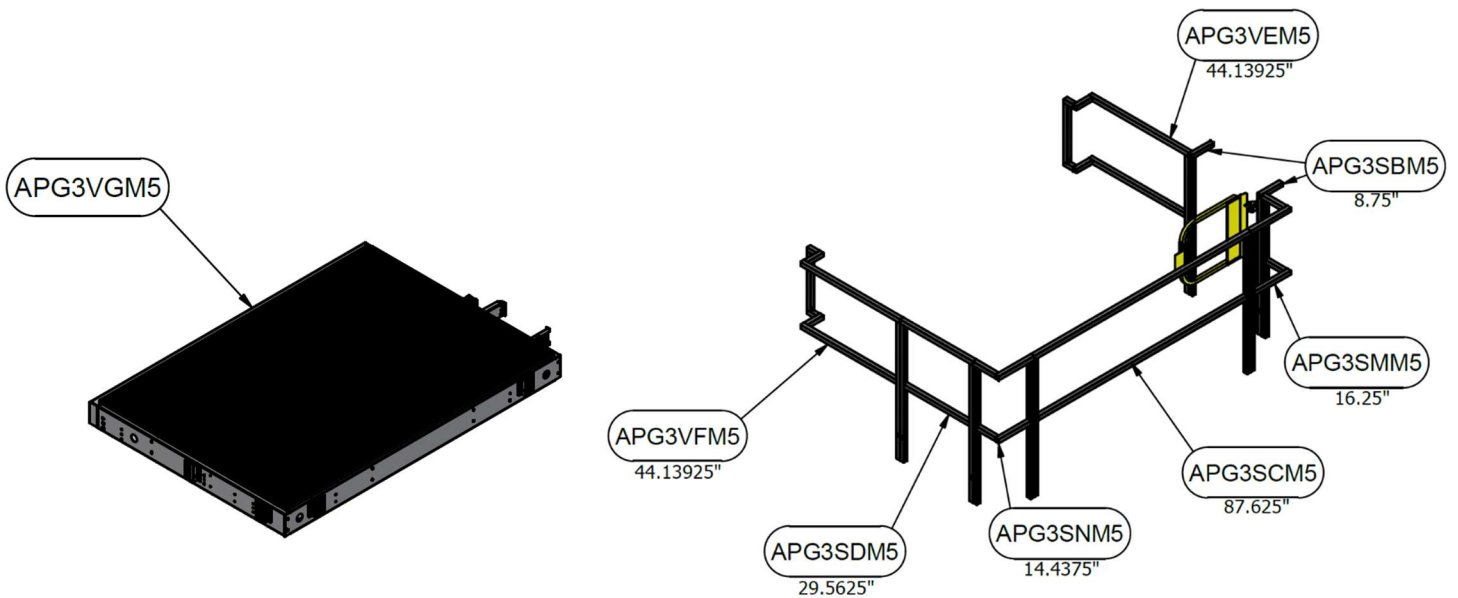

Figure 14. External Platform

Figure 15. External Platform Railing Installation
Circled items are paired with dimensions and refer to part numbers specified in the submittal.

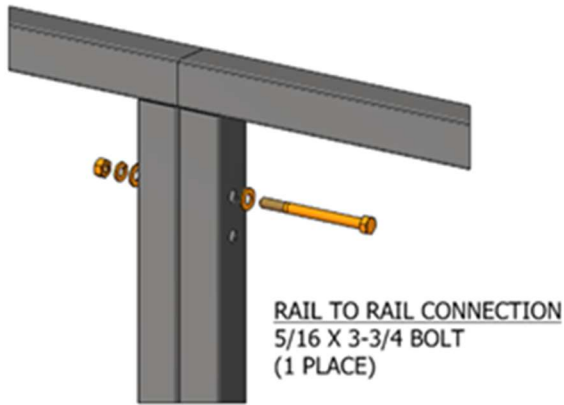

Figure 16. External Platform Railing Installation

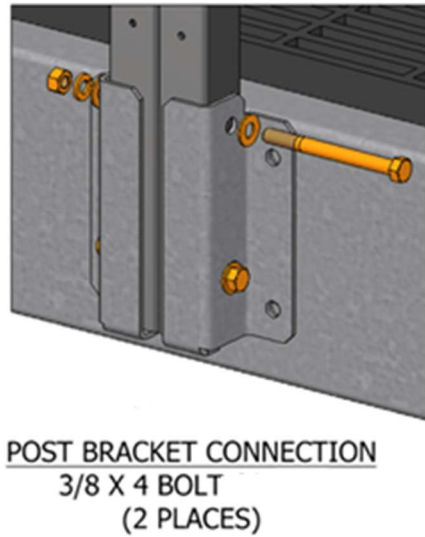

Figure 17. External Platform Railing Installation

3. Lift external platform to the extended c-channels on the lower section shown **Figure 18**. Lift external platform from the four lifting locations shown in **Figure 19**. Do not lift external platform with toeboards (shown in orange in **Figure 23**) installed.

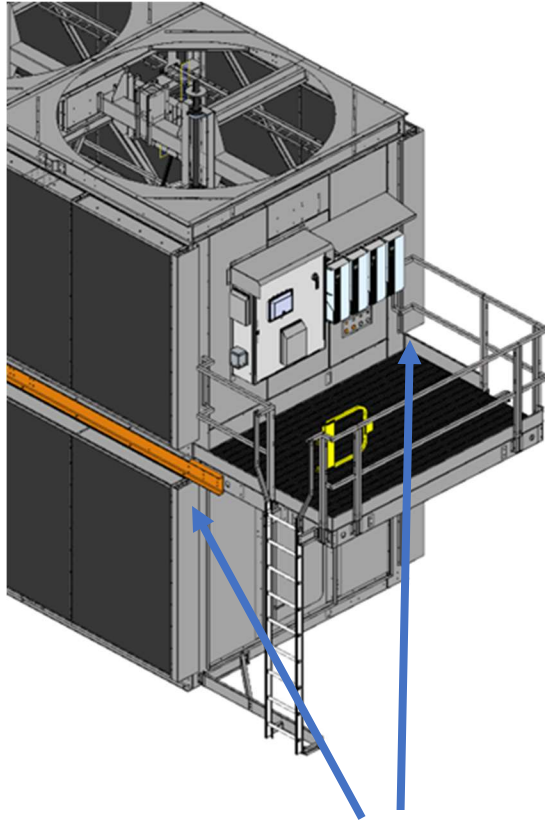

Figure 18. External Platform Extended C-Channels

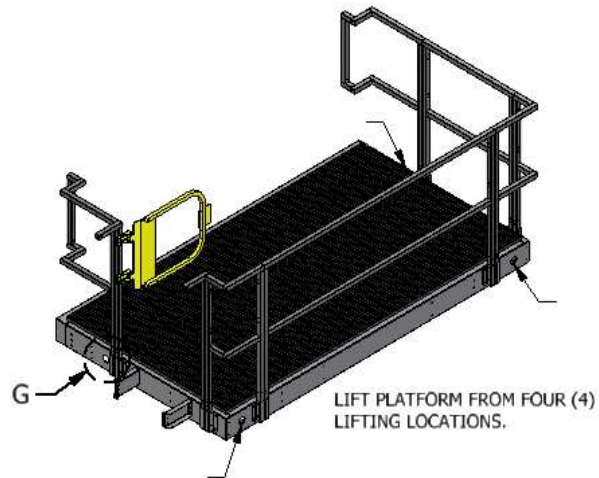
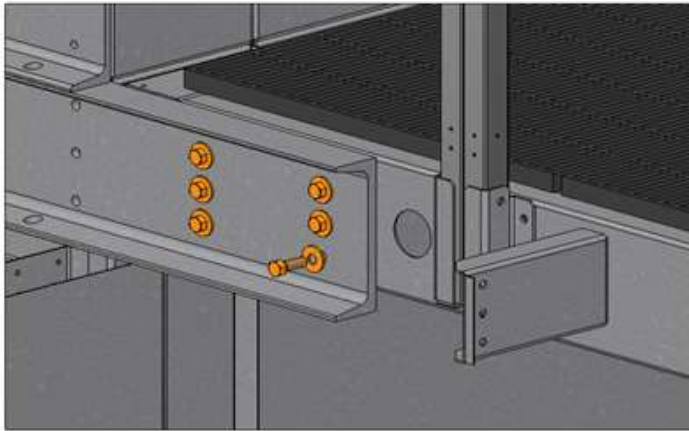
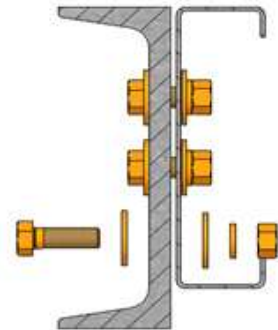

Figure 19. External Platform Lifting Locations

- Bolt the external platform to the extended c-channels using 1/2" Grade 5 hardware per



PLATFORM TO UNIT CONNECTION
 1/2 X 1-1/2 BOLT
 (6 PLACES)
 (TYP. BOTH SIDES)



SECTION VIEW

- Figure 200.

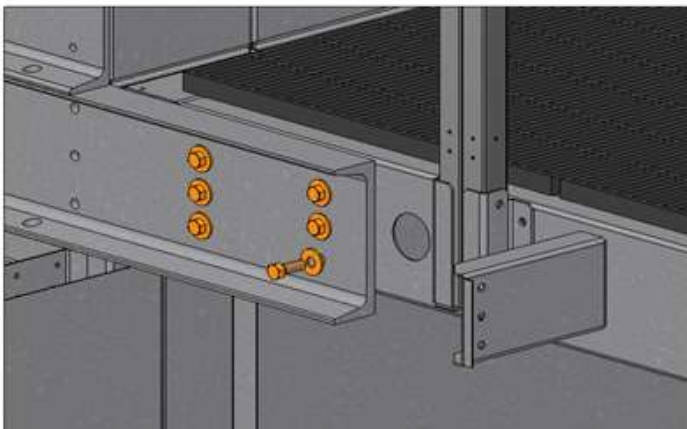

PLATFORM TO UNIT CONNECTION
 1/2 X 1-1/2 BOLT
 (6 PLACES)
 (TYP. BOTH SIDES)

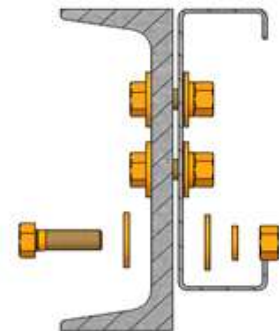

SECTION VIEW

Figure 200. External Platform to Unit Connection

- Bolt the external platform railing to the unit using 5/16" hardware as shown in **Figure 21**.

RAILING TO UNIT CONNECTION
 5/16 X 2-1/2 BOLT
 (2 PLACES)
 (TYP. BOTH SIDES)

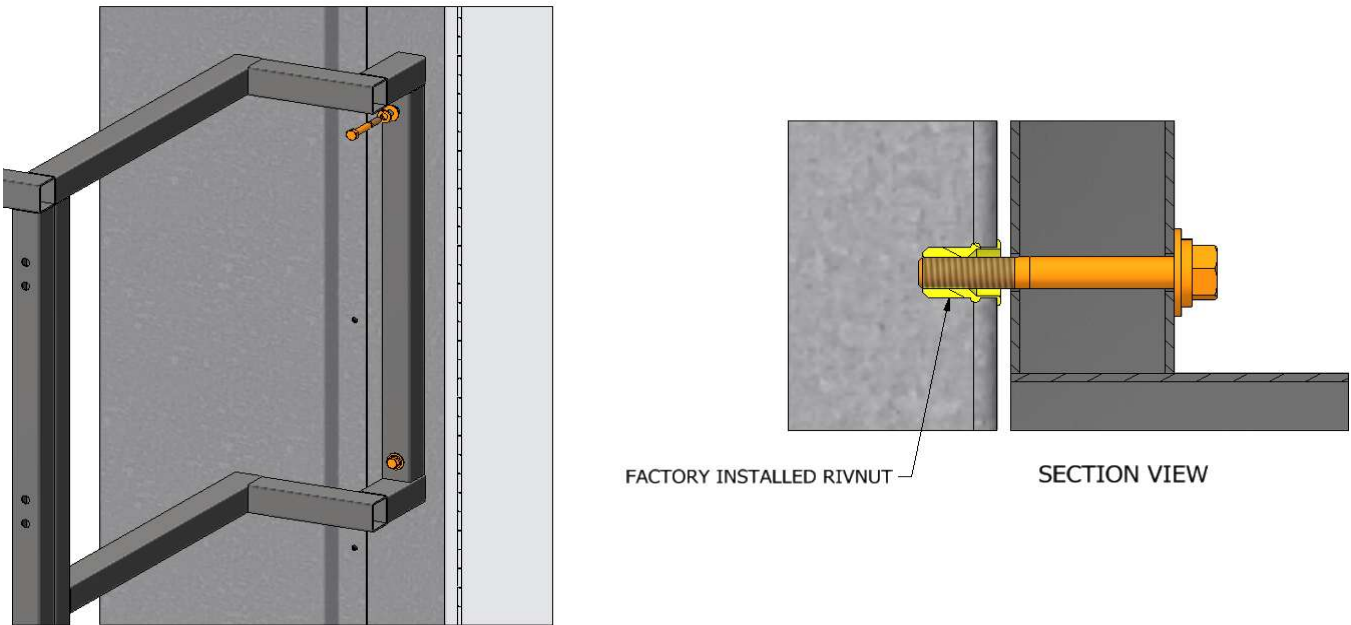

Figure 21. External Platform Handrail to Unit Connection

7. Install the external platform toeboards as shown in **Figure 2**, **Figure 213** and **Figure 224**. Circled items in **Figure 2** correspond to specific part numbers in the unit submittal. See unit submittal for details.

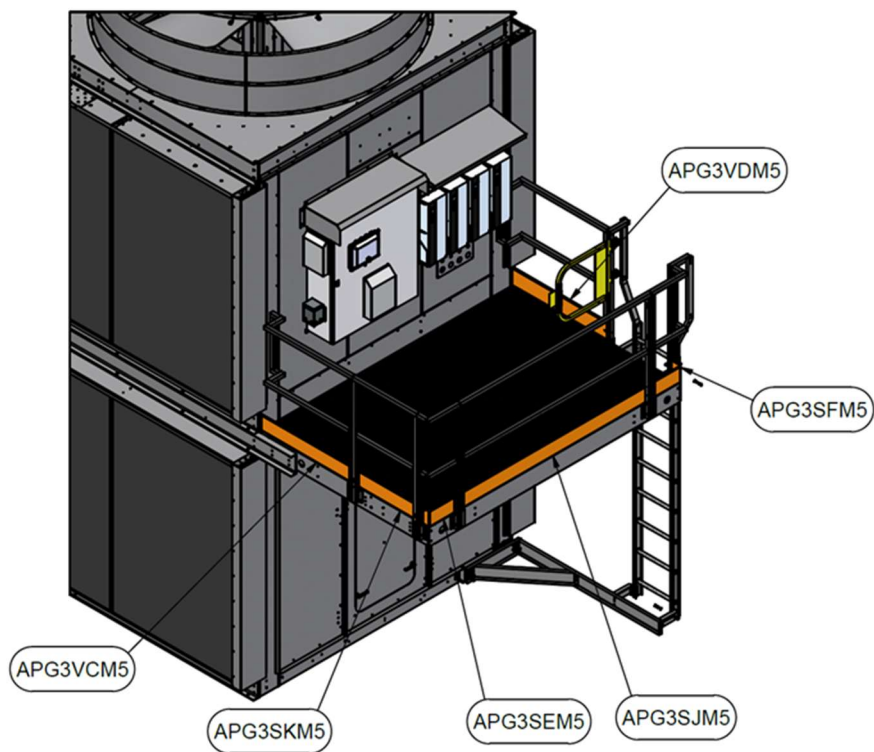
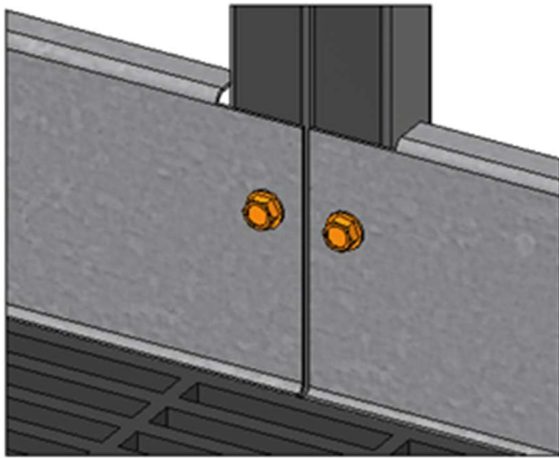

Figure 22. External Platform Toeboard Installation



TOEBOARD TO RAILING
5/16 TAPPER
(2 PLACES)

Figure 213. External Platform Toeboard to Railing Installation



TOEBOARD TO PLATFORM
5/16 TAPPER
(1 PLACE)

Figure 224. External Platform Toeboard to Platform Installation

External Platform Ladder Installation

The installed external platform ladder is shown in **Figure 13**.

1. Install the external platform bottom ladder supports per **Figure 235** and **Figure 246**.
2. Install the external platform ladder per **Figure 257** through **Figure 270**. Ladder can be on either side of platform. See submittal for details regarding external platform ladder installation location.

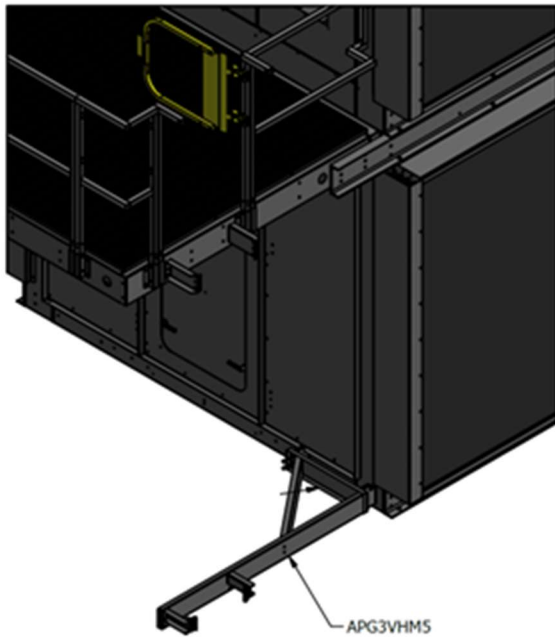

Figure 235. External Platform Bottom Ladder Support Location

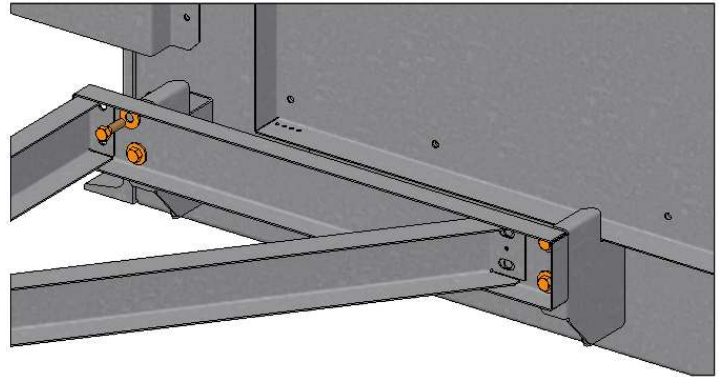

Figure 246. External Platform Bottom Ladder Support Installation

3/8" x 1-1/4" Hardware Qty. 4 Locations

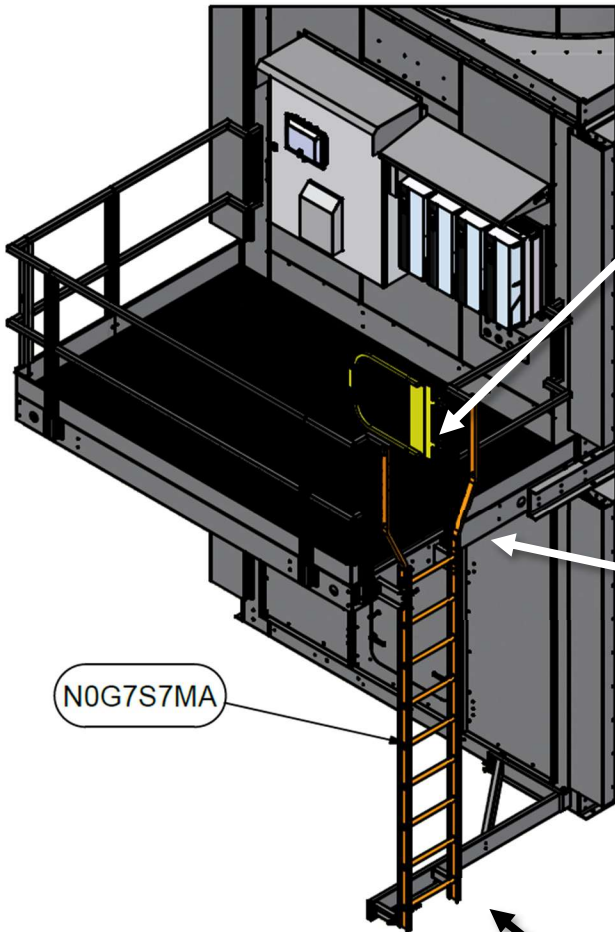

Figure 257. External Platform Ladder Location

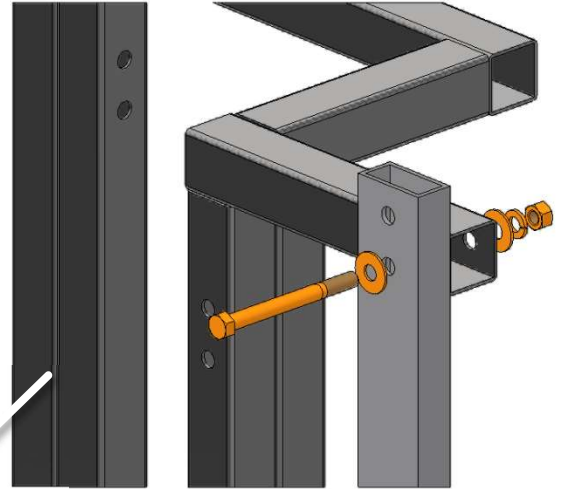

Figure 268. External Platform Ladder Flare to Railing

3/8" x 4" Hardware Qty. 2 Locations

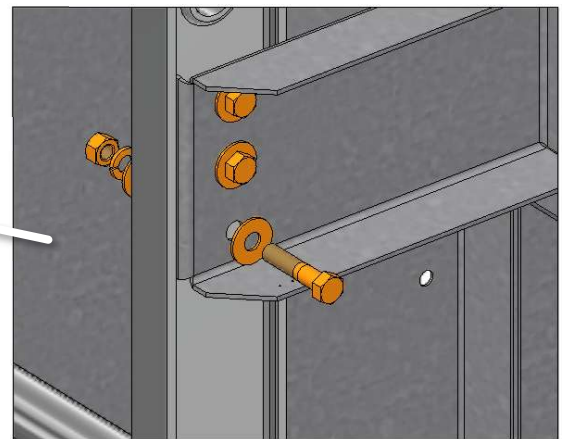

Figure 29. External Platform Ladder to Platform

3/8" x 1-3/4" Hardware Qty. 6 Locations

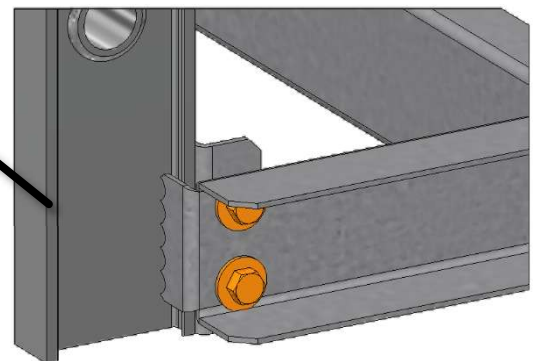

Figure 270. External Platform Ladder to Bottom Ladder Support

3/8" x 1-1/4" Hardware Qty. 4 Locations

Access Door Platform Installation

This section sets forth the procedures for installing the access door platform (illustrated in **Figure 281A and 31B**). Platform location may depend on site specifications and can be on either side of the unit. Handrails and toeboards are pre-assembled to the access door platform. See submittal for job-specific details.

1. Starting with the factory assembled access door platform shown in **Figure 281A and 32B**, align the platform railings and platform with the factory-installed brackets on the customer-specified platform installation location per the submittal.
2. Mount access door platform and railings to factory-installed brackets with eight (8) 3/8" x 1-1/4" bolts. See **Figure 30** for bolting details.

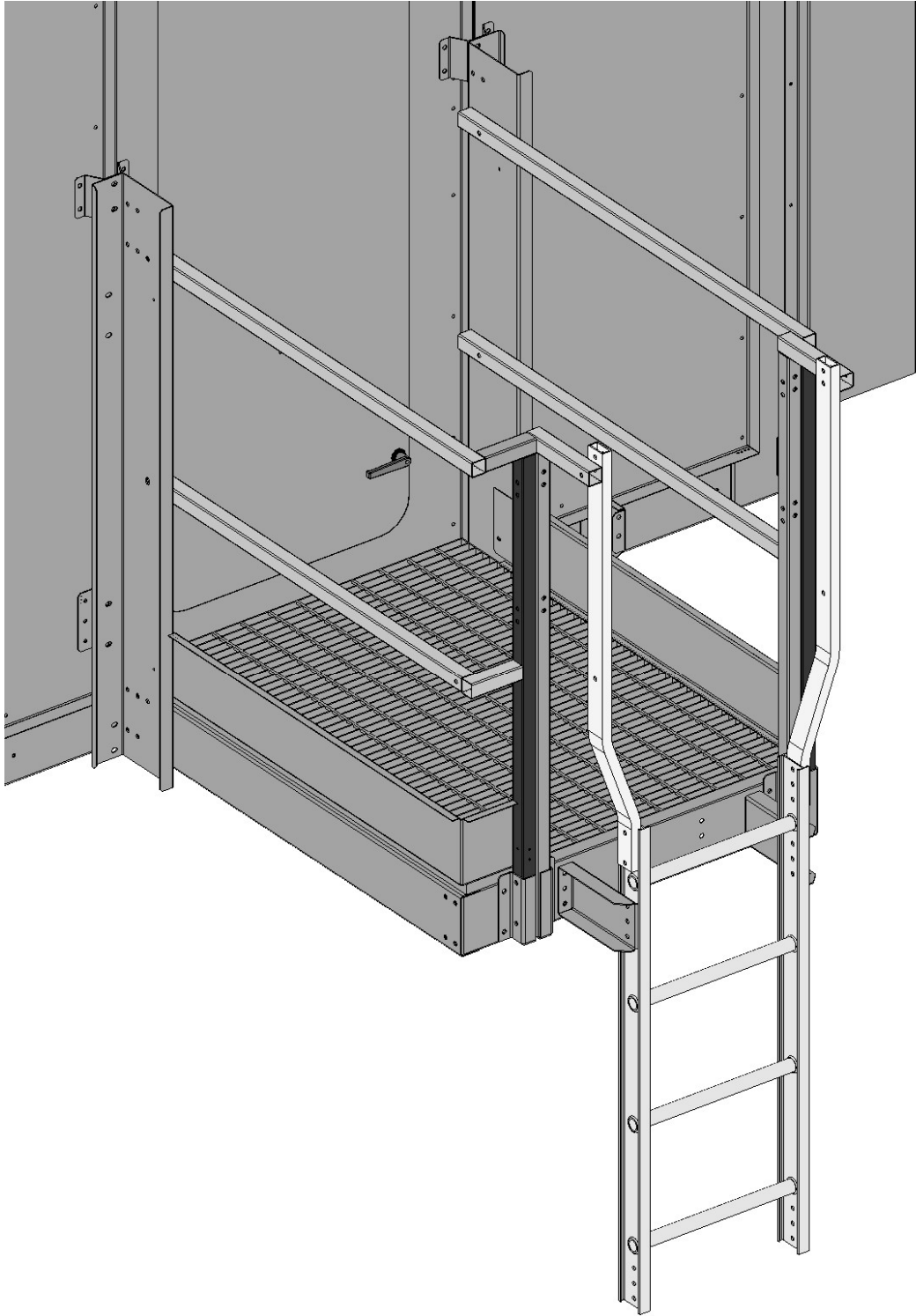

Figure 281A. Access Door Platform Location – Note, ladder safety cage not shown for clarify

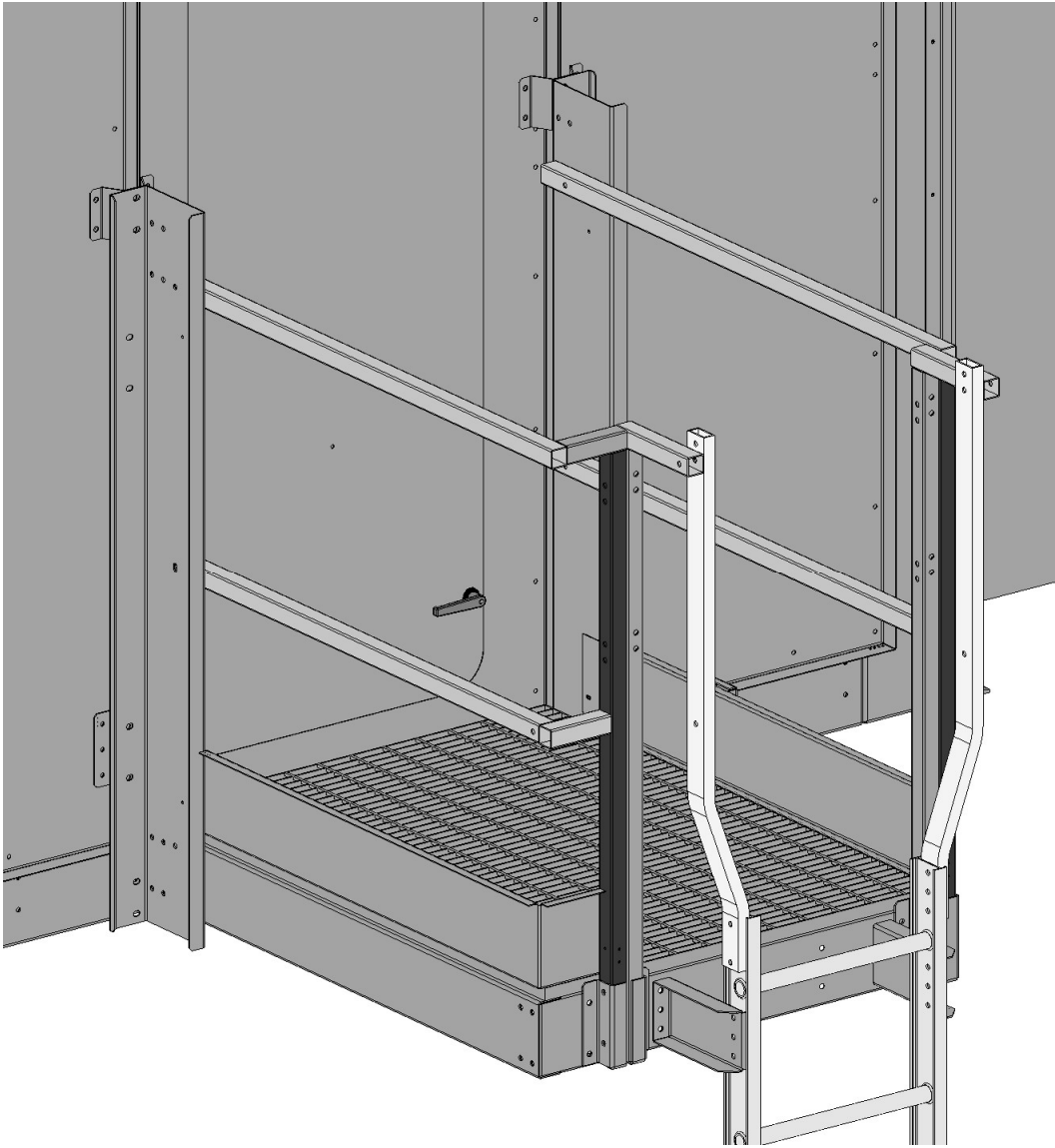

Figure 291B. Access Door Platform Location Close Up – Note, ladder safety cage not shown for clarity

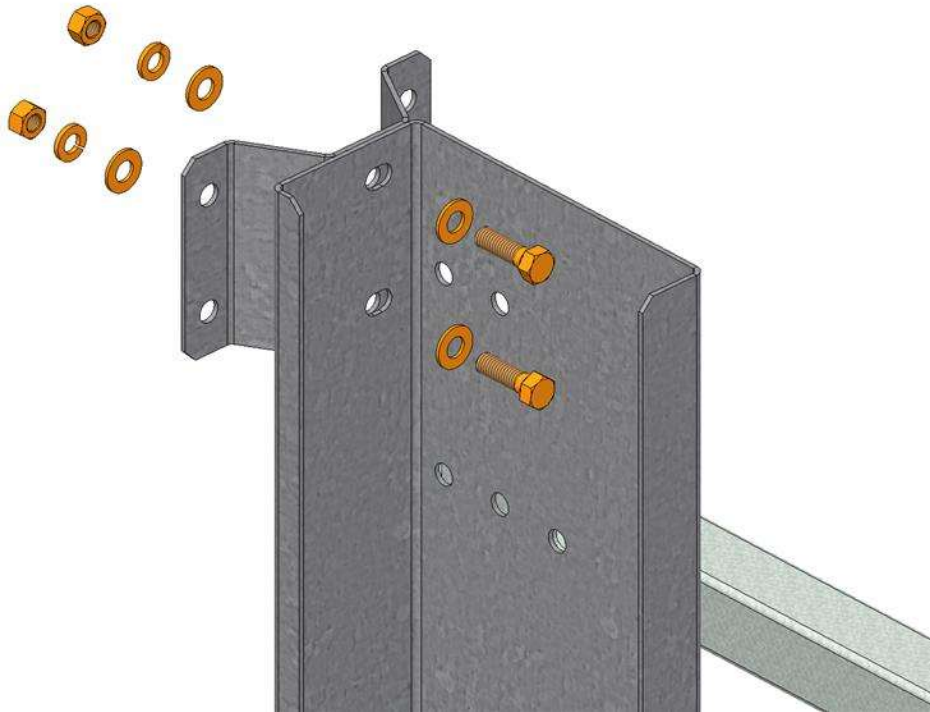

Figure 302. Access Door Platform Brackets

3/8" x 1-1/4" Hardware Qty. 4 locations

Access Door Platform Safety Gate

This section sets forth the steps for installing the access door platform safety gate. The access door platform safety gate is shown in **Figure 313**.

1. Align safety gate with railing.
2. Secure safety gate in two locations using four (4) 5/16" x 4" bolts. See **Figure 313** for bolting details.

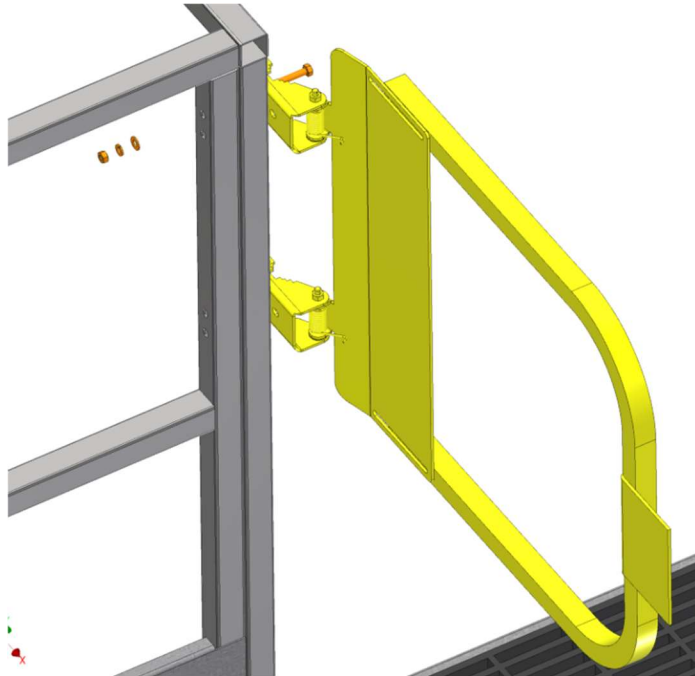

Figure 313. Access Door Platform Safety Gate

5/16" x 4" Hardware Qty. 2 locations.

Internal Service Platform Ladder Installation

This section sets forth the steps for installation of the internal service platform ladder. The internal service platform, internal service platform ladder and safety gate are shown in **Figure 324**.

1. Attach the ladder to the upper ladder brackets using 3/8" bolts. See **Figure 335, Detail B**.
2. Attach the ladder to the lower ladder brackets using 3/8" bolts. See **Figure 33, Detail C**.
3. Secure the ladder flares to the platform railing posts using 3/8" bolts. See **Figure 335, Detail A**.

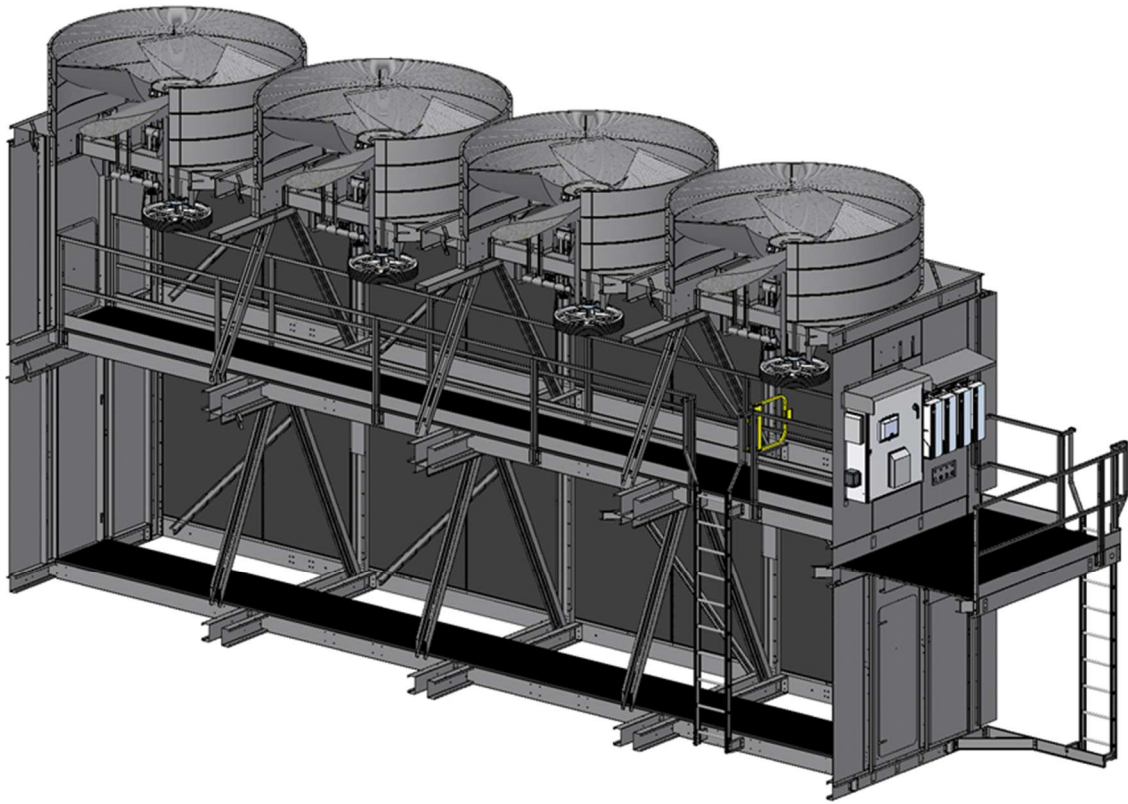

Figure 324: Internal Service Platform, Ladder & Safety Gate

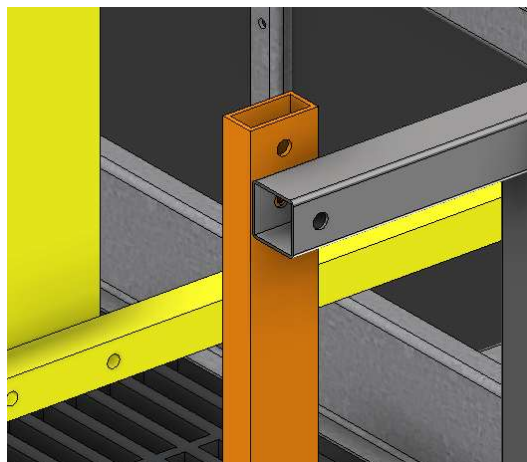
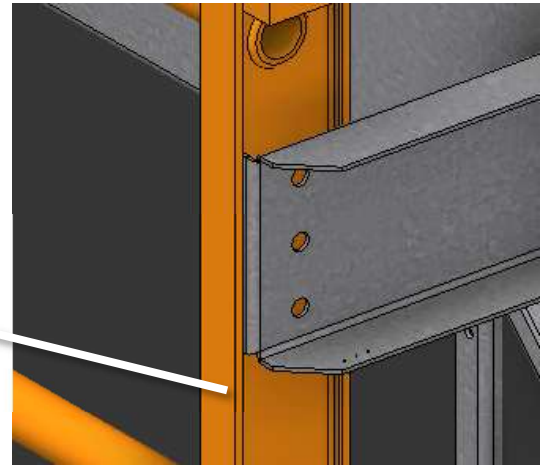
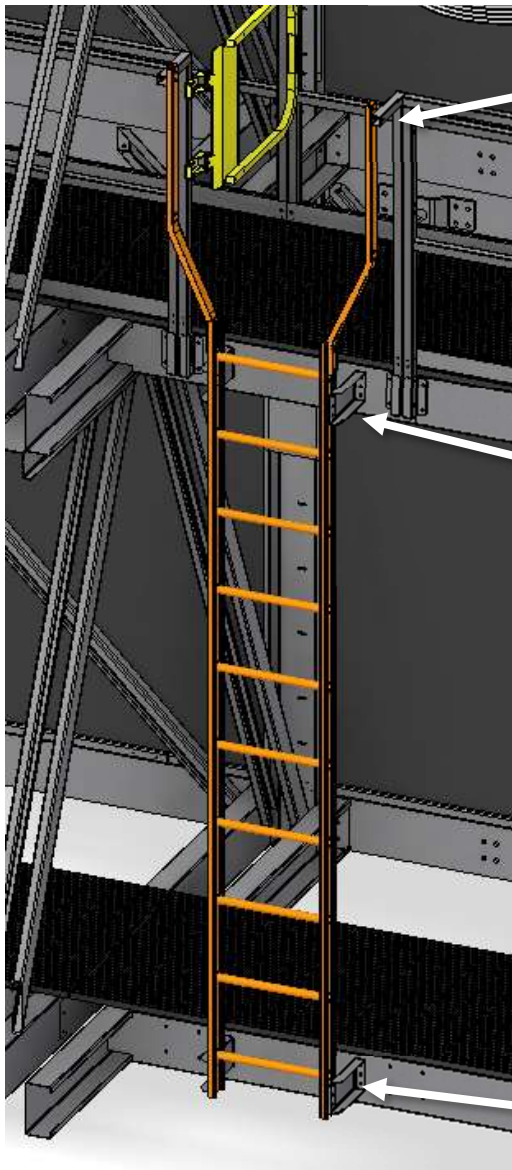
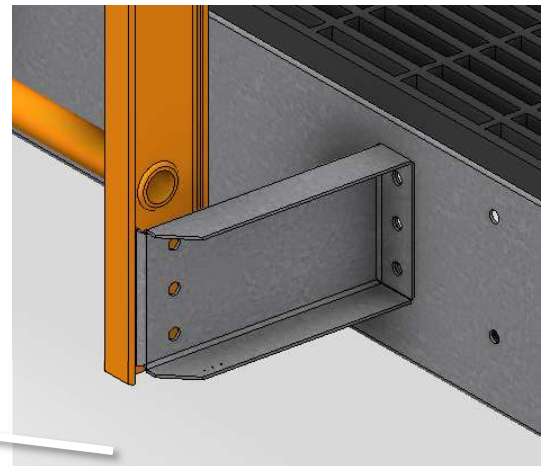

Figure 35: Internal Service Platform Installation Detail A Qty. 2 bolts



Detail B Qty. 6 bolts



Detail C Qty. 6 bolts

Figure 33. Internal Service Platform Ladder Installation

Internal Service Ladder Safety Gate Installation

1. Align safety gate hinge to specified location in **Figure 34** .
2. Attach the gate to the platform with four (4) 5/16" x 3-3/4" bolts per **Figure 35**.

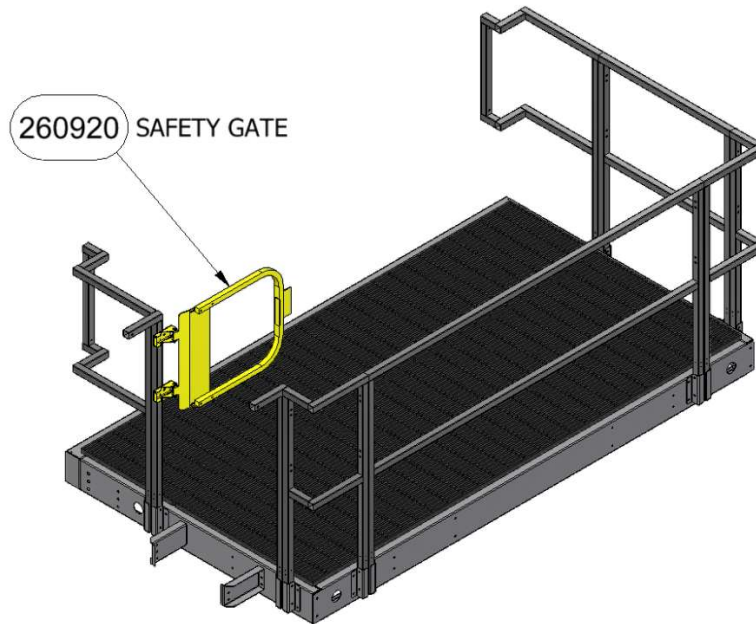

Figure 34. Ladder Opening Safety Gate Location

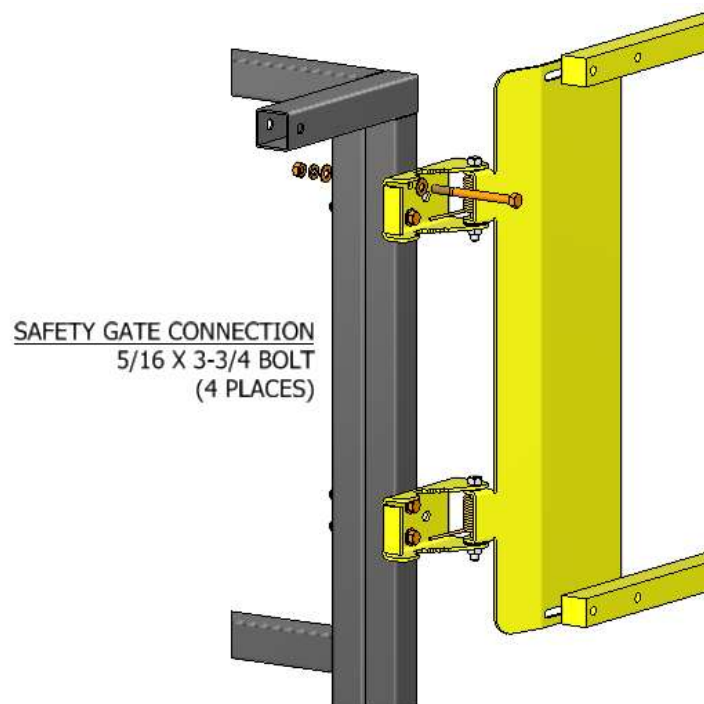

Figure 35. Ladder Opening Safety Gate Installation

Whisper Quiet™ Fan Installation

⚠ DANGER: Fans may start at any time. Rotating fan equipment can cause severe personal injury or death upon contact. Adequate safeguards (including the use of protective enclosures where necessary) should be taken with this equipment to safeguard the public from injury and to prevent property damage. Never step or walk on the fan guard. Always disconnect, lock out, and tag out all power sources to the fan motor(s) before performing any inspection or maintenance.

If your Model TDFS includes a Whisper Quiet™ fan (which can be confirmed by reference to the unit submittal), the fan ships loose and will require field installation as set forth in this section. (Standard fans ship installed from the factory with no additional field installation required.) For belt tensioning instructions before equipment startup, see the O&M manual.

Remove Fans from Shipping Crate and Prepare for Lifting

NOTICE Do not use power tools on the Whisper Quiet™ fan to avoid damaging mounting components or damage to the fan.

Install the fan – following the instructions below -- prior to installing the fan cowl extensions.

1. The center seal disk, shown in **Figure 36**, must be removed before the lifting slings are attached to fan blade shanks. Note the assembly orientation of the seal disk hardware for reassembly and remove it according to the seal disk hardware detail in **Figure 37**. If there is not enough clearance on the seal disk stud or not enough resilient or aluminum washers, the resilient washer can sit directly on the bottom nut without an aluminum washer in between. One resilient washer above the seal disk is acceptable.

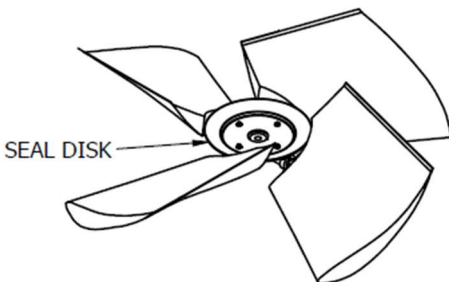

Figure 36: Seal disk

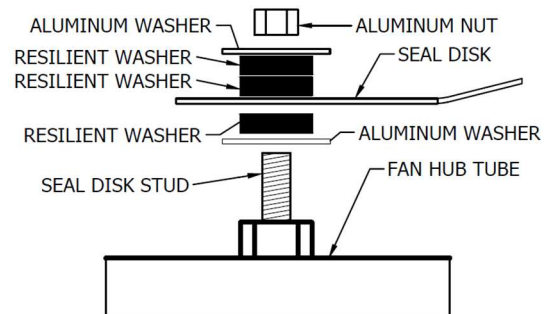

Figure 37: Seal disk hardware detail

2. Wrap or loop slings suitable for lifting the fan around the blade shanks per **Figure 38**.

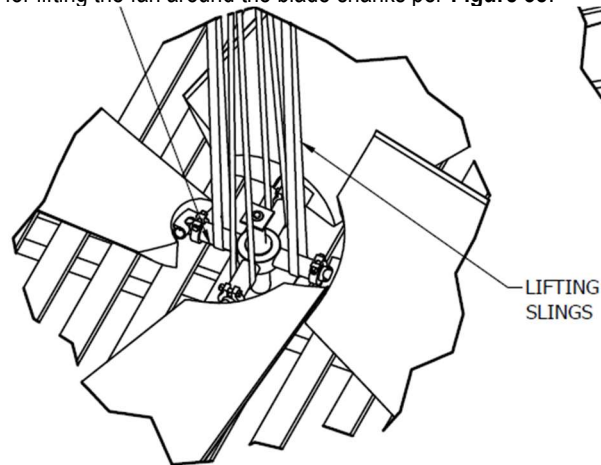

Figure 38: Attaching slings

3. Remove the bolt, PVC spacer, and plywood spacers from the shipping mount per **Figure 39**.

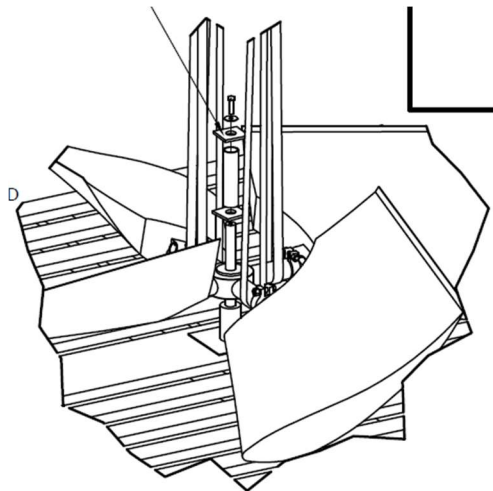

Figure 39: Shipping mount hardware details

4. Lift the fan off shipping crate per **Figure 40**, being careful not to damage the blades.

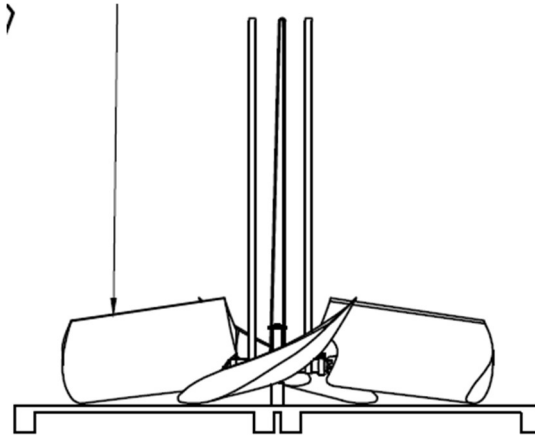

Figure 40: Lifting fan from shipping mount

Install Fan

Confirm that the bushing is installed on the fan hub per **Figure 41**. If it is not installed, then install it as follows:

1. Align the threaded holes on the inner diameter of the hub to the slots on the outer diameter of the bushing with the cap screws between the hub and the bushing.
2. Insert the bushing into the hub.
3. Tighten the cap screws until the bushing is almost fully engaged in the hub, leaving slight play between the bushing and the hub to facilitate installation on the shaft.

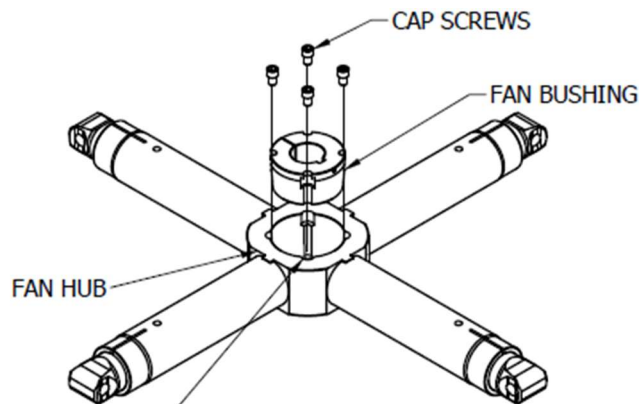

Figure 41: Installing fan bushing

4. Position the fan over the keyed fan shaft per **Figure 42**.

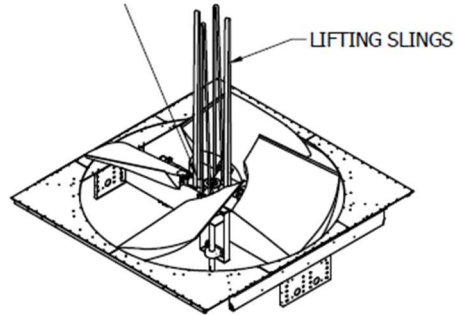

Figure 42: Positioning over fan shaft

Install the fan as follows:

1. Lower the hub and bushing on the shaft until the hub contacts the locking collar per **Figure 43**.

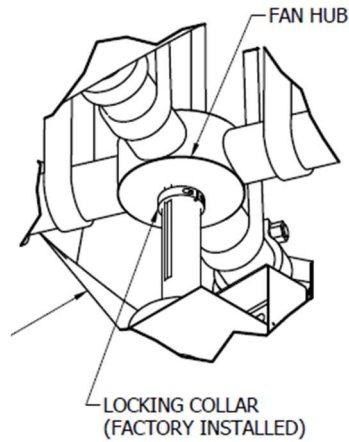

Figure 43: Hub detail

2. Align the bushing keyway with the shaft keyway per **Figure 44**.

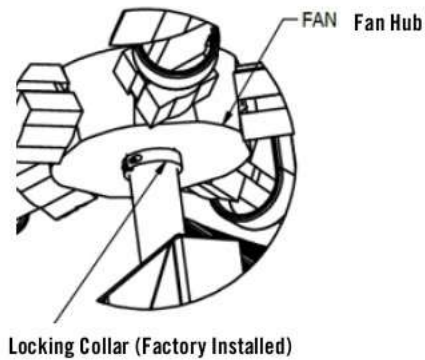

Figure 44: Bushing Keyway

3. Insert the shaft key from the top of the hub assembly.
4. Sequentially tighten the cap screws to firmly engage the bushing in the hub and then tighten the cap screws until the torque specified in **Table 1** is reached.

Bushing Type	Bushing O.D.	Hex Key Size	Torque
U	4"	10mm	50 ft-lb

Table 1: Bushing torque values

- Replace the fan seal disk per **Figure 45** and tighten the nuts until the rubber seal washer compresses to the diameter of the flat washer. See the seal disk hardware detail in **Figure 37**.

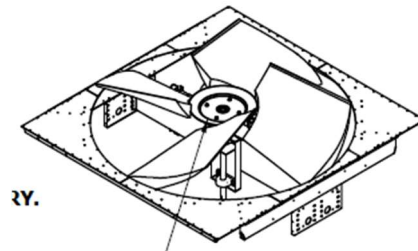

Figure 45: Replacing seal disk

- Tightening the fan hub bushing may cause the fan to lift away from the locking collar. If needed, raise the locking collar to contact the hub and tighten the locking collar screw to 50 ft-lbs (67.79 N-m) per **Figure 43**.

Once the fan is installed, lock the lower bearing locking collar in **Figure 46** and **Figure 47** as follows:

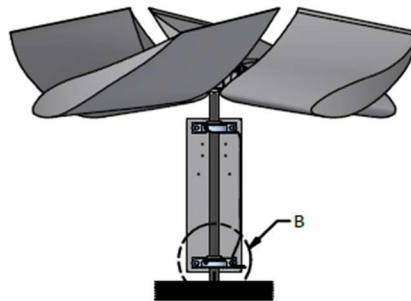

Figure 46: Lower bearing locking collar

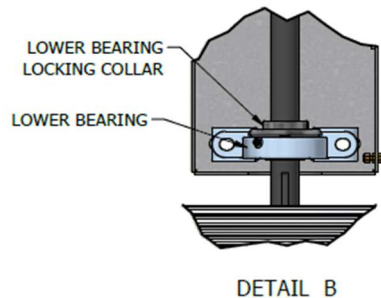

Figure 47: Lower bearing locking collar detail

- Slide the cam of the bearing locking collar over the cam on the inner ring of the lower bearing per **Figure 48**.

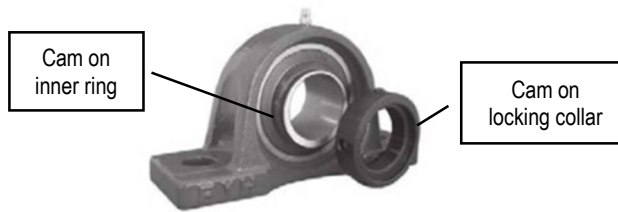

Figure 48: Bearing photo

2. Press the locking collar against the inner ring and turn clockwise when viewed from above until they are tightly engaged.
3. Place a drift pin in the hole of the lower bearing locking collar per **Figure 49**, and tap the drift pin with a hammer in the direction of shaft rotation.
4. In the same hole where the drift pin was placed, tighten the lower bearing locking collar set screw to 23 ft-lbs (31 Nm).

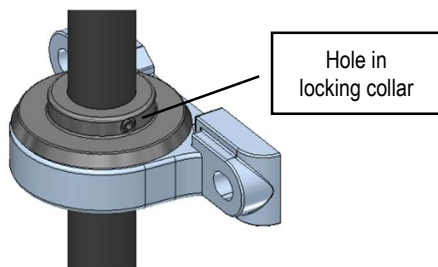

Figure 49: Locking collar detail

Installing and Tensioning the Belt

The fan belt ships loose for field installation. Install the belt onto the driver and driven sheaves.

An over-tensioned belt will create a high radial load on the lower bearing, and a loose belt will create slippage at the driver sheave, which increases belt wear. To ensure proper belt tensioning:

1. Tension the belt by turning the adjustment nut clockwise to move the motor base away from the fan shaft per **Figure 50**.

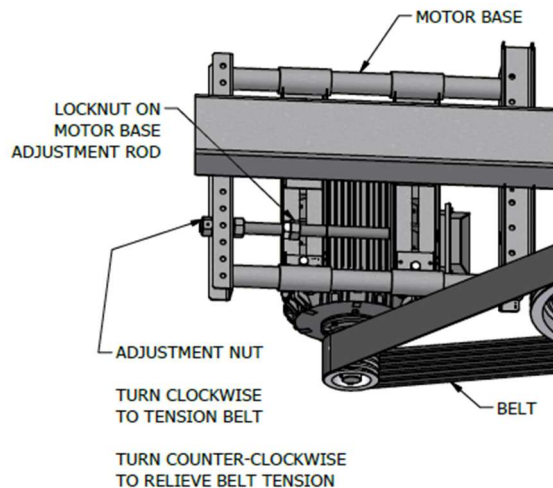

Figure 50: Belt tensioning

2. Rotate the drive system by hand while tensioning to evenly distribute the tension throughout the belt.
3. Using your hand, apply a moderate force of approximately 16-20 lbf (71-89 N) evenly across the width of the belt in the center of the belt span between the sheaves. If the belt deflects between $\frac{1}{2}$ " (13 mm) as shown in **Figure 51**, then the belt tension is adequate. Belt tension may also be verified using a sonic belt tension meter with the recommended belt tension frequency range at 15-18 Hz.
4. Once the proper tension has been achieved, tighten the locknut against the motor base.

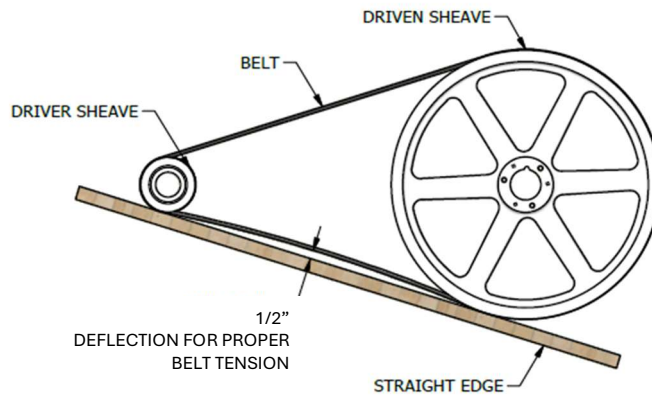

Figure 51: Belt deflection

Assemble Fan Cowls

Install the fan cowl segments together per **Figure 52** using $\frac{3}{8}$ " x 1" grade 5 bolts with 2 flat washers, 1 lock washer, and 1 nut per bolt as shown in **Figure 53**.

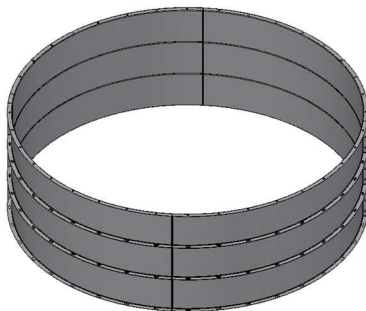

Figure 52: Fan cowl assembly

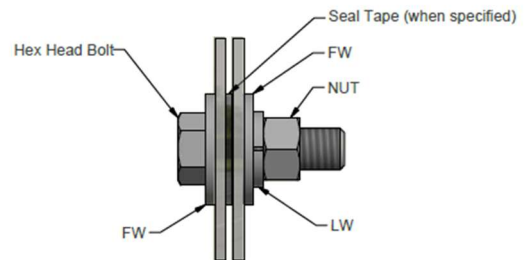

Figure 53: Fan cowl hardware detail

Check Fan Blade Tip Clearance

1. Rotate the fan by hand and check the tracking and tip clearance per **Figure 54**.

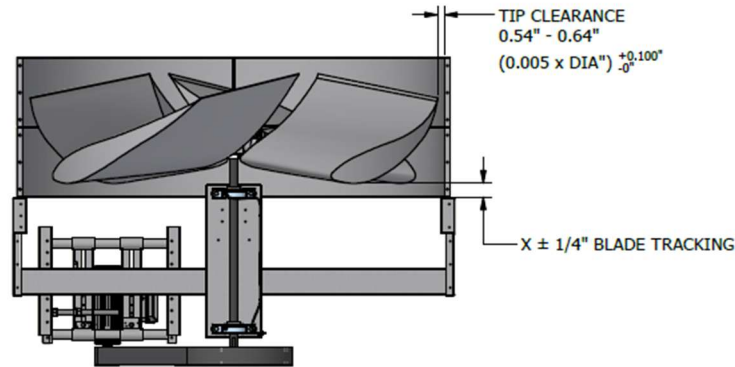

Figure 54: Tip clearance and tracking

2. Blade tracking should be within $\pm 1/4$ " (6.5 mm).
3. Clearance between fan blade tips and cowls should be equal around the circumference of the cowl.
4. If blade tracking or tip clearance are not within the acceptable range, then the fan shaft must be adjusted as follows:
 - a. Support the fan with slings.
 - b. Relieve tension in the belt. Refer to back to **Figure 50** for information on belt tensioning.
 - c. Loosen the bearing locking collars.
 - d. Loosen the bearing mounting bolts.
 - e. The bearings can be shifted left or right within the hardware slots.
 - f. The shaft can be tilted forward or backward by inserting shims between the bearing and the support plate, either on top or bottom per **Figure 55**.
 - g. Re-tighten the bearing bolts to 80 ft-lbs (108.5 Nm).
 - h. Tighten upper locking collar.
 - i. Remove the slings.
 - j. Tighten the lower locking collar after the weight of the fan is supported by the upper locking collar.
 - k. Apply rust preventative such as Rust-Veto® to the exposed areas of the shaft above and below the fan bushing.

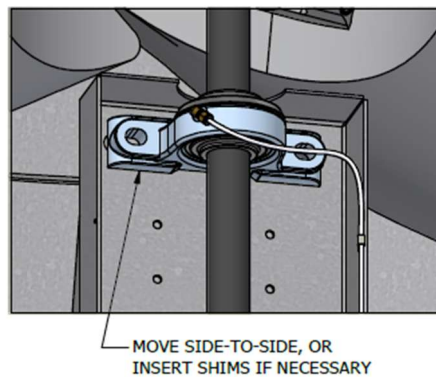
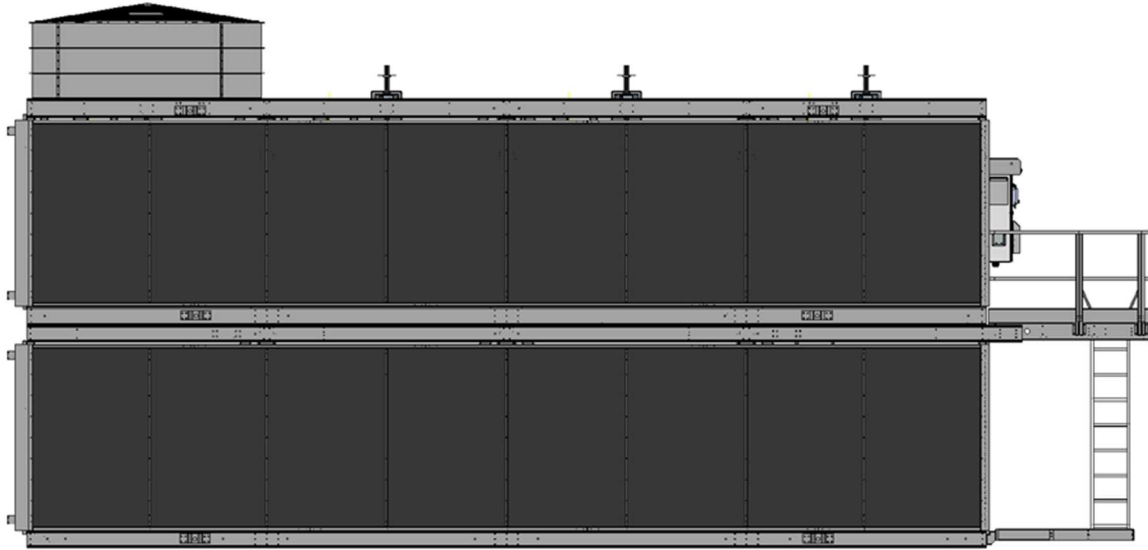

Figure 55: Adjustments to correct tip clearance

Fan Cowl Extension Installation for Whisper Quiet™ Fan



Install the Whisper Quiet™ fan and assemble the fan cowls according to the instructions in this manual before installing fan cowl extensions. **Figure 59** shows one fan cowl extension installed. Affix assembled Whisper Quiet™ fan cowl extension(s) to unit using specified hardware per **Figure 57**.

Figure 56: Fan Cowl Extension Installation, Example of one of four installed on left of diagram

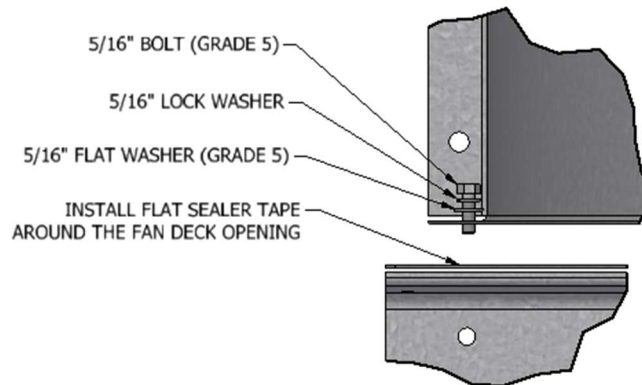

Figure 57: Fan Cowl Extension Close Up Installation of Hardware, Qty. 36 bolts, lock washers, and flat washers per cowl

Fan Guard Installation

All fan guards for all fan models ship loose and require installation. Follow the steps below for fan guard installation.

1. Using six U-bolt assemblies, fasten the two halves of the fan guard together as illustrated in **Figure 58, Detail B**. Locate the U-bolt assemblies along the seam between the two guard halves per “U-bolt spacing on fan guards” in **Figure 58**.
2. Gradually tighten both nuts of the U-bolt assembly, alternating from one to the other, until 20-25 ft-lbs (27-39 Nm) of torque is achieved.
3. Using 3/8" x 1-1/2" long bolts, mount the fan guard to the top of fan cowl extension(s). Mount the fan guard as illustrated in **Figure 58, Detail A** for the ends of the seam where the two guard halves join together, and **Figure 58, Detail C** for all other locations around the fan guard perimeter.

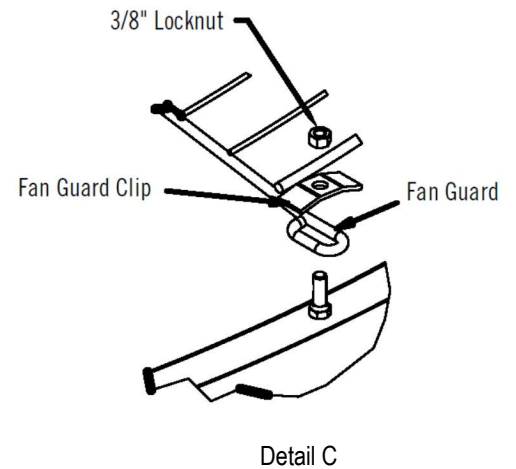
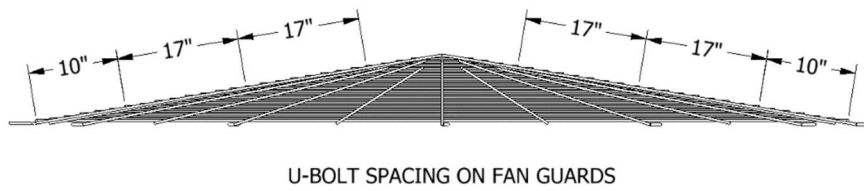
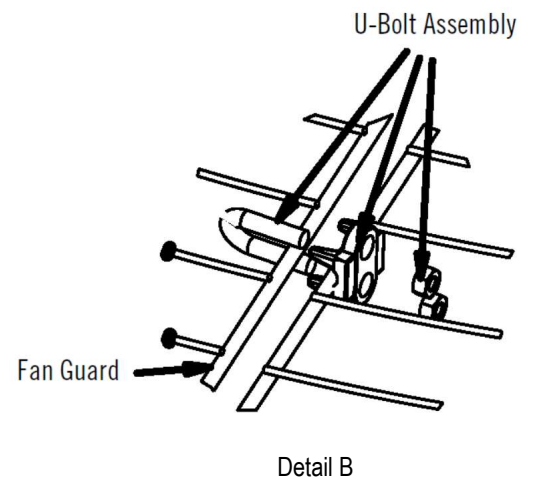
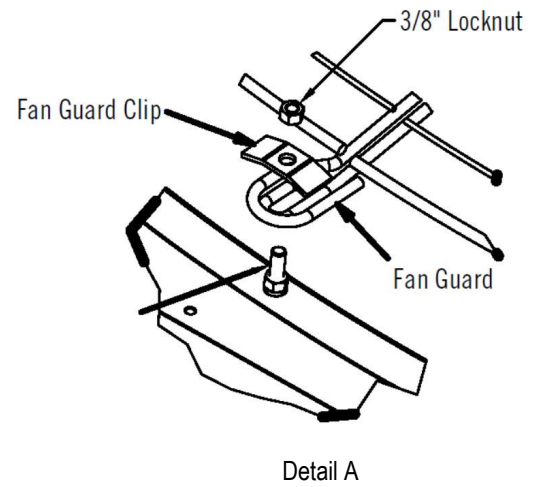
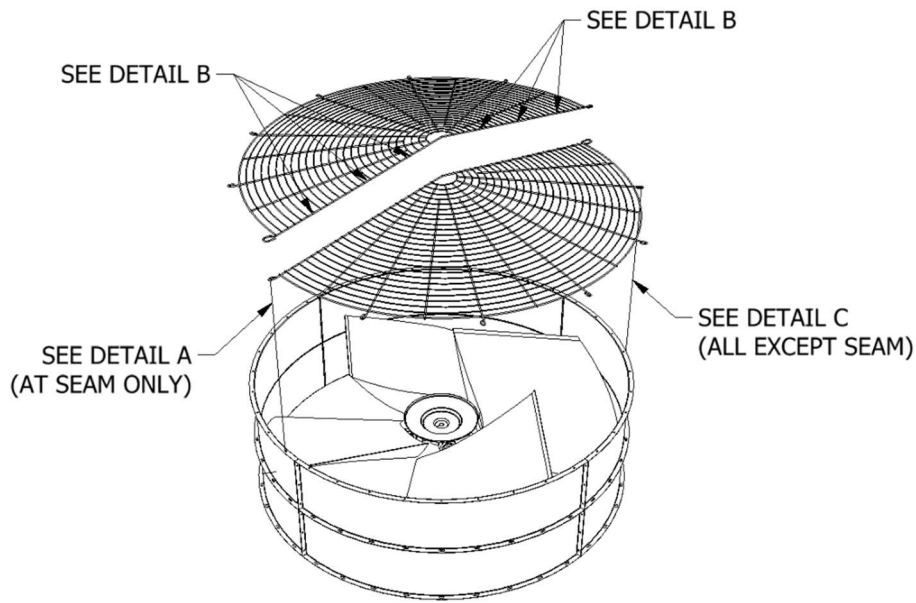

Figure 58. Fan Guard Assembly

5. Other Installation Matters

Equipment Wiring

The equipment either includes a factory-wired control panel with separate VFDs, or it includes a factory-wired terminal box. Wiring and electrical installation must be compliant with NFPA 70 (NEC) along with state and local codes for your location. For details on job-specific configurations and wiring, see the project submittal.

Flange Coil Connections

Units configured with flange coil connections are supplied with class 150 floating flanges. For shipment, sheet metal blanks are zip tied to floating flanges to secure flanges and to seal off the coil connection. Remove zip ties and sheet metal blank prior to installation. Install flanges according to [ASTM B16.5 Pipe Flanges and Flanged Fittings](#) which covers pressure-temperature ratings, materials, dimensions, tolerances, marking, testing, and methods of designating openings for pipe flanges and flanged fittings.

Beveled for Weld and Threaded Coil Connections

Units configured with beveled for weld and threaded coil connections are supplied with male pipe thread rated for 150 psi (1034 kPa). Refer to unit submittal drawings for connection size.

Plain Pipe Stub Coil Connections Nitrogen Charge Removal

To protect the inside coil surface from corrosion, coils supplied with a plain pipe stub coil connection are capped and charged with nitrogen from the factory. Plain pipe stub coil connections must be field cut and beveled before welding. Prior to cutting the pipe stub, relieve the pressure inside each coil using the factory installed Schrader valve. The plain pipe stub coil connection is a specialized option. Refer to sales representative for more information.

NOTICE

The pre-cooler pads are made of flammable material and should be removed when performing hot work on or near the unit. No actions that can generate sparks should be performed on or near the unit.

NOTICE

To prevent excessive degradation do not attempt to remove the pre-cooler pads while wet.

TrilliumSeries® Dry Cooler - TDFS

RIGGING & ASSEMBLY INSTRUCTIONS



baltimoreaircoil.com