

**FACE A/B**  
(CONNECTIONS TYPICAL EACH END)

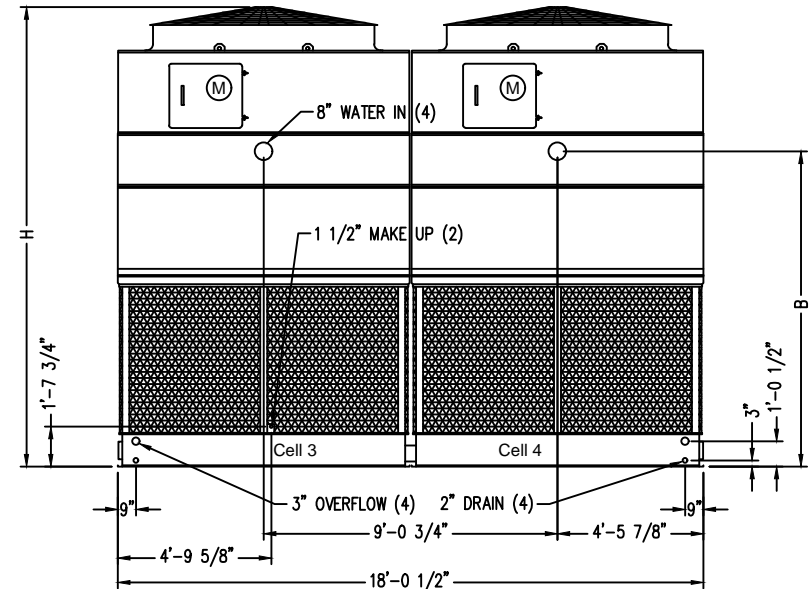

**FACE C**  
(CONNECTIONS TYPICAL EACH SIDE)

**Notes**

- 1) Unless otherwise indicated, connections 3" and smaller are NPT. Connections 4" and larger are grooved to suit a mechanical coupling and beveled for welding.
- 2) All dimensions are in feet and inches. Weights are in pounds and include options and accessories.
- 3) For weight loadings and support requirements, refer to the suggested steel support drawing.
- 4) The area above the fan discharge must be unobstructed.
- 5) Piping must not be supported by the tower inlet or outlet connections.
- 6) Unit weights include selected accessories.
- 7) M = Motor location.

Model Number	Shipping Weight	Operating Weight	Heaviest Section	"H"	"B"	"D"	"L"
PT2-1009A-1x4	18410	32190	3320	16'-0 1/4"	10'-2 1/4"	8'-4"	7'-1 3/8"
PT2-1009A-2x4	20020	33800	3670	17'-0 1/4"	11'-2 1/4"	9'-4"	7'-1 3/8"
PT2-1009A-3x4	21880	35660	3990	18'-0 1/4"	12'-2 1/4"	10'-4"	7'-1 3/8"
PT2-1009A-4x4	22860	39230	3990	20'-0 1/4"	14'-2 1/4"	10'-4"	9'-1 3/8"
PT2-1009A-5x4	23980	40360	4270	21'-0 1/4"	15'-2 1/4"	11'-4"	9'-1 3/8"

ORDER NO:

DATE:



**BALTIMORE  
AIRCOIL COMPANY**

**PT2 Quad Cell Unit Print  
Internal Belt Drive**

DRAWING NUMBER:  
**GEN-PT2-1009A QUAD-CELL**