



# PRODUCT SPOTLIGHT: Cooling Tower Duty Motors



BAC has worked with motor manufacturers to develop rigorous standards for cooling tower duty motors. While our competition and supply companies might offer replacement motors that will initially function in a cooling tower, only BAC offers top quality motors that will reliably continue to operate in the harsh cooling tower environment, resulting in less motor failures, downtime, and replacements. Here at BAC, we believe in our motors so much that we stand by them with a 7 year warranty when the motor space heater is wired according to the motor wiring diagram.

## Industry Rated Performance and Durability:

- ✓ Built according to inverter duty NEMA Standard MG1, Section IV, Part 31 and designed for operation in 100% humidity
- ✓ IEEE 112, Method B, tested ensuring performance and survivability
- ✓ IP55 rating for superior protection against pressurized water jets from all directions

## Energy Efficient with Flexible Installation:

- ✓ Meets or exceeds all NEMA Premium and Consortium for Energy Efficiency energy requirements with efficiency values certified by UL (CSA C390)
- ✓ Meet Design B torques, maintaining exceedingly high breakdown and locked rotor torque while providing the highest rated efficiency levels
- ✓ Designed to operate in either horizontal, shaft up or shaft down positions
- ✓ Multiple end shield drain plugs for all position mounting

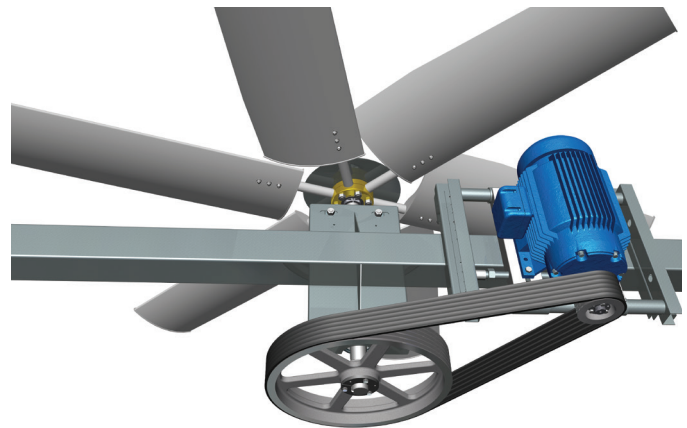

PRODUCT SPOTLIGHT:

# Cooling Tower Duty Motors CONTINUED

## Rugged Features Increase Longevity

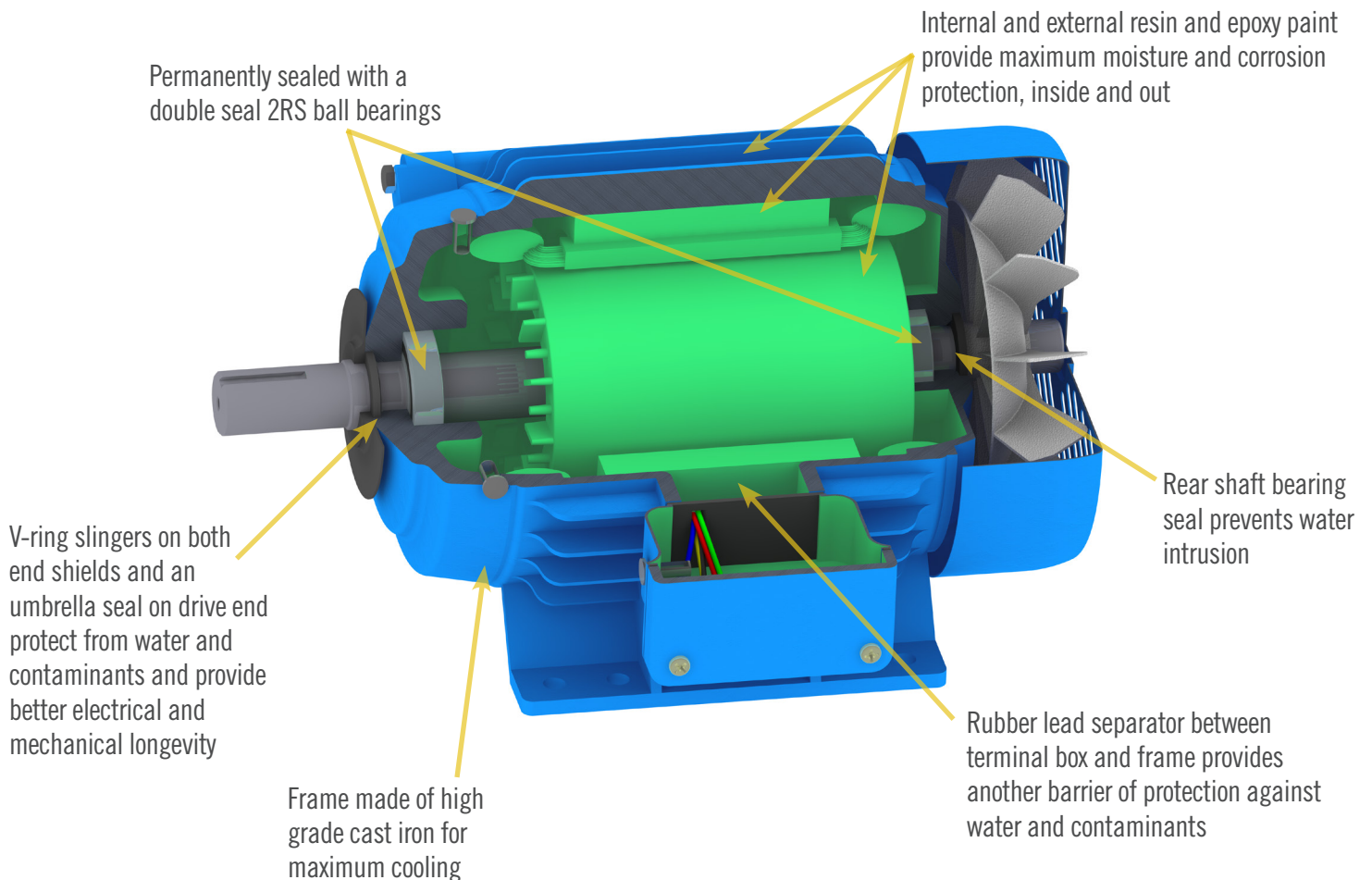

**NOTE:** As of 2017, space heaters are shipped with all motors. There is a 7 year warranty on the motor when the space heater is wired according to the wiring diagram.

## Many of our motor models ship same day!



**BALTIMORE  
AIRCOIL COMPANY**

7600 Dorsey Run Road, Jessup, MD 20794 > Telephone: (410) 799-6200 > Fax: (410) 799-6416

PRD33/2017

© 2017 Baltimore Aircoil Company

