



Baltimore Aircoil Company

VCA Evaporative Condensers

RIGGING AND INSTALLATION

INSTRUCTIONS

Introduction

Series V Products should be rigged and assembled as outlined in this bulletin. All personnel should review these procedures prior to the actual rig to ensure all necessary equipment will be available at the jobsite.

Locate the unit nameplate on the connection end of the unit and record the unit serial number and model number for reference.

Have a copy of the unit certified drawing available. If you do not have a copy of this drawing, contact the local BAC Representative.

CHECK UNIT BEFORE RIGGING

When the unit is delivered, check it thoroughly to ensure all required items have been received and are free of shipping damage prior to signing the bill of lading.

Inspect the following parts:

- Sheaves and Belts
- Bearings & Bearing Supports
- Motor(s), Fans & Shafts
- Water Distribution System
- Miscellaneous Items:
- Coils
- Strainers
- Float Valve Assembly
- Eliminators
- Interior & Exterior Surfaces

If required for field assembly, the following parts will be packaged and placed inside the basin-fan section: Sealer, 3/8" bolts, and some accessory items. A checklist inside the envelope attached to the side of the unit marked "Contractor's packet" indicates what parts were included with the shipment and their location. Remove all accessory items from the basin before the unit is assembled.

UNIT WEIGHTS

Before rigging, the weight of each section should be verified from the unit certified drawing. Some accessories add additional weight as shown on the respective accessory drawings.

WARNING: These weights are approximate and should be confirmed by weighing before lifting when available hoisting capacity provides little margin for safety. In preparing for a lift, individuals responsible for rigging must inspect the equipment before the lift to make certain that all water or other liquids have been drained from the unit and any debris removed.

During cold weather, the pre-lift procedure must include removal of accumulations of ice and snow, which will not naturally drain and would add substantially to the equipment's lifting weight.

ANCHORING

CAUTION: Unit must be properly anchored before operation begins.

Seven-eighths inch (7/8") diameter bolt holes are provided in the bottom flange of the basin for bolting the unit to the support beams. Refer to the support drawing for locations of the mounting holes. Anchor bolts are supplied by others.

LEVELING

The support beams and unit must be level for proper operation. Shims should not be used between the basin and support beams to level the unit.

WARNING: Operation, maintenance, and repair of this equipment should be undertaken only by qualified personnel. Proper care, procedures, and tools must be used in handling, lifting, installing, operating, maintaining, and repairing this equipment to prevent personal injury and/or property damage.

WARNING: Adequate precautions, appropriate for the installation and location of these units, should be taken to safeguard the public from possible injury and the equipment and the premises from damage.

Solid bottom panels may be desirable or necessary for safety and other reasons depending on site location and conditions.

WARNING: PVC eliminators on this product are not designed to support the weight of a person or to be used as a storage or work surface for any equipment or tools. Use of these PVC eliminators as a walking, working or storage surface may result in injury to personnel or damage to the equipment. If covering a unit which has PVC eliminators, do not use a clear plastic tarpaulin.

For Safety Precautions refer to the units Operating and Maintenance Manual.

WARRANTIES: Refer to the Limitation of Warranties applicable to and in effect at the time of the sale/purchase of these products.

FREEZE PROTECTION: Units must be protected by mechanical and operational methods against damage and/or reduced effectiveness due to possible freeze-up. Refer to the Product & Application Handbook, Operation and Maintenance Manual or contact the local BAC Representative for protection alternatives.

RIGGING

To simplify rigging and installation, most units ship in sections consisting of the basin-fan and casing sections.

WARNING: The basin and casing components must be rigged separately. Never assemble the unit before lifting as the lifting devices provided are not designed to support the weight of the entire assembled unit. The proper rigging sequence is to lift the basin-fan section into place, apply sealer to the basin where the casing(s) will be located, and then lift the casing(s) into place. Lifting devices have been provided on all sections. Spreader bars, spanning the full width of the section, must be used between the lifting cables to prevent damage to the section.

WARNING: In the event of extended lifts or where hazards exist, the lifting devices should be used in conjunction with safety slings placed under the unit.

Refer to Table 1 for the recommended minimum size of the spreader bar and the recommended vertical dimension "H" from the lifting device to the spreader bar.

Table I

Model Number	Number of Basin Sections	Number of Casing Sections	Basin Section			Casing Section	
			Spreader Bar Length "L"	Minimum Height "H"	Center of Gravity	Spreader Bar Length "L"	Minimum Height "H"
VCA - 122A to 191A	1	1	5'	10' 5"	2-5/8"	5'	8' 10"
VCA - 174A to 259A	1	1	6'	10' 5"	3-1/4"	6'	8' 10"
VCA - 261A to 322A	1	1	8'	10' 5"	3-7/8"	8'	8' 10"
VCA - 323A to 446A	1	1	8'	15' 7"	3-7/8"	8'	8' 10"
VCA - 300A to 512A	1	1	10'	10' 5"	6-3/8"	10'	8' 10"
VCA - 460A to 779A	1	1	10'	15' 7"	6-3/8"	10'	8' 10"
VCA - 662A to 1024A	2	2	10'	10' 5"	6-3/8"	10'	8' 10"
VCA - S700A to S884A	2	1	10'	10' 5"	6-3/8"	10'	12' 4"
VCA - 920A to 1558A	2	2	10'	15' 7"	6-3/8"	10'	8' 10"
VCA - 302A to 661A	1	1	12'	10' 5"	7-3/8"	12'	8' 10"
VCA - 526A to 1010A	1	1	12'	15' 7"	7-3/8"	12'	8' 10"
VCA - 605A to 1321A	2	2	12'	10' 5"	7-3/8"	12'	8' 10"
VCA - S870A to S1204A	2	1	12'	10' 5"	7-3/8"	12'	12' 4"
VCA - 930A to 2019A	2	2	12'	15' 7"	7-3/8"	12'	8' 10"

1. Rig the basin section. The rigging hook must be placed above the section's center of gravity as detailed in (Figure 1 and 2).

Caution: Before proceeding, bolt the basin section securely to the supporting steel.

Units with multiple cold water basins may employ flume boxes to equalize the water level in the basin of each cell.

Follow the directions on page 4 for flume box installation.

2. Wipe down the flanges with acetone to remove dirt, or moisture which may have accumulated during shipment and storage.

3. Install sealer tape on the mating flange of the bottom section to ensure an airtight seal between the top and bottom section. Apply a layer of 1/4" x 1" sealer tape around the face of the flange over the centerline of the holes.

Do not overlap or stretch too thinly at the corners. When it is necessary to splice the sealer, press the two ends together to form a smooth, continuous strip. The sealer is to be spliced only along the flanges with holes (Figure 3).

Note: The sealer tape is trapezoidal in shape and must be installed with the wide side down (Figure 4).

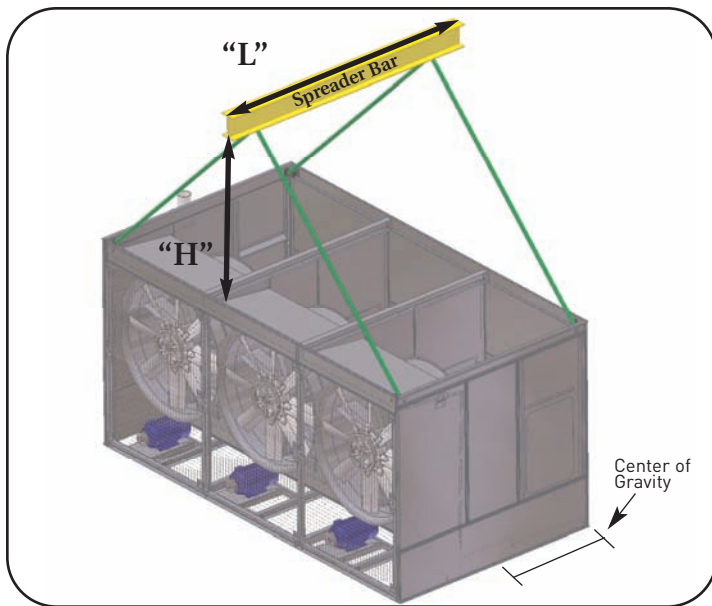

Figure 1

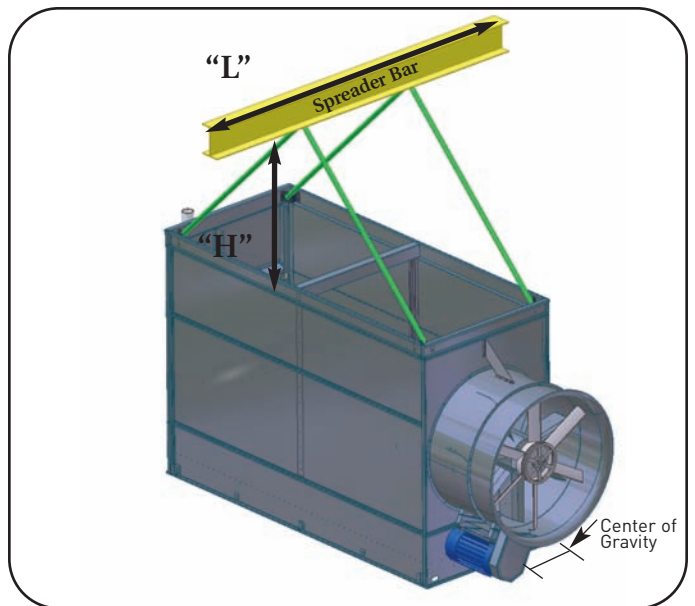

Figure 2

4. Lower the flexible connection on the pump discharge piping below the elevation of the basin section top section before rigging the casing section.

5. After applying sealer tape to the basin flanges, remove the casing skid. Lift the casing and position it so that the casing flanges are about 2" above the basin section. Do not permit the casing to damage the sealer.

6. Insert drift pins downward through the four corner screw holes in the casing (Figure 5). Continue to lower the casing slowly, maintaining alignment with the drift pins until it rests on the basin section.

7. Working from the corners towards the center, install the 3/8" bolts, using the drift pin to align the screw holes.

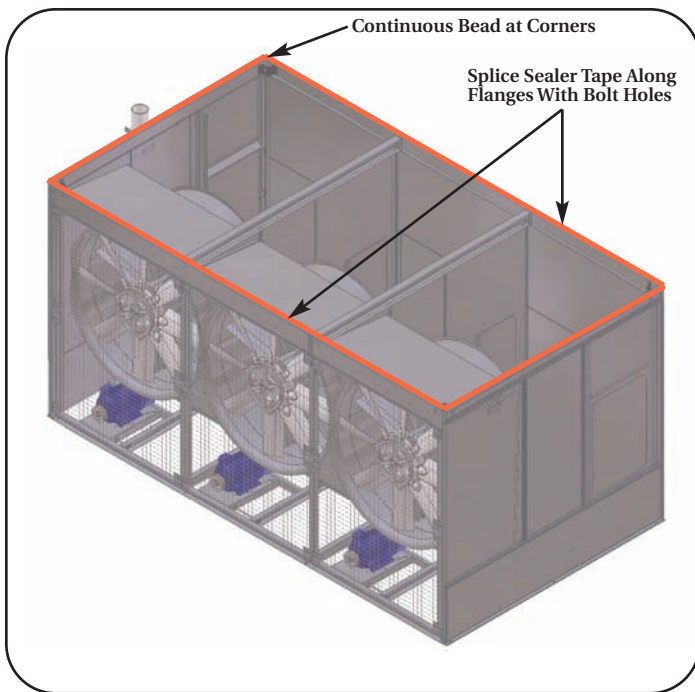

Figure 3

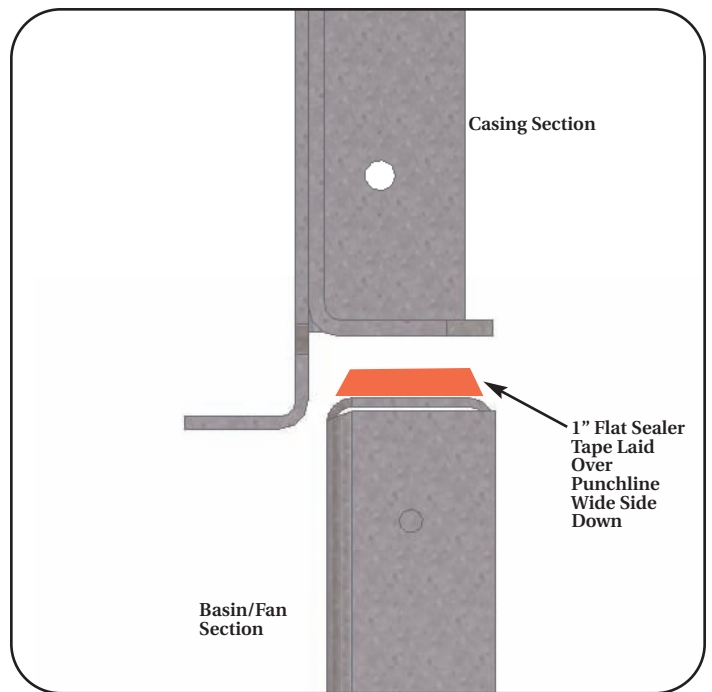

Figure 4

8. Secure the hose connecting the sections of the pump discharge pipe with the hose clamps provided.
9. On units with more than one casing, install the remaining casings using the same procedure as the first. When installing two or more casings, on the basin section, sealer tape must be applied to both cross flanges. (Figure 3)
10. On units operating with a remote sump tank, install a bleed line with valve between the system circulating pump discharge riser and a convenient drain. Locate the bleed line in a portion of the riser piping that drains when the pump is off. Units that are furnished with a factory-installed circulating pump include a bleed line with valve.

CAUTION: Bleed valves should remain open when the unit is in operation, unless the bleed rate is automatically controlled by a water treatment system. Bleed rates may be found in the Operating and Maintenance Manual.

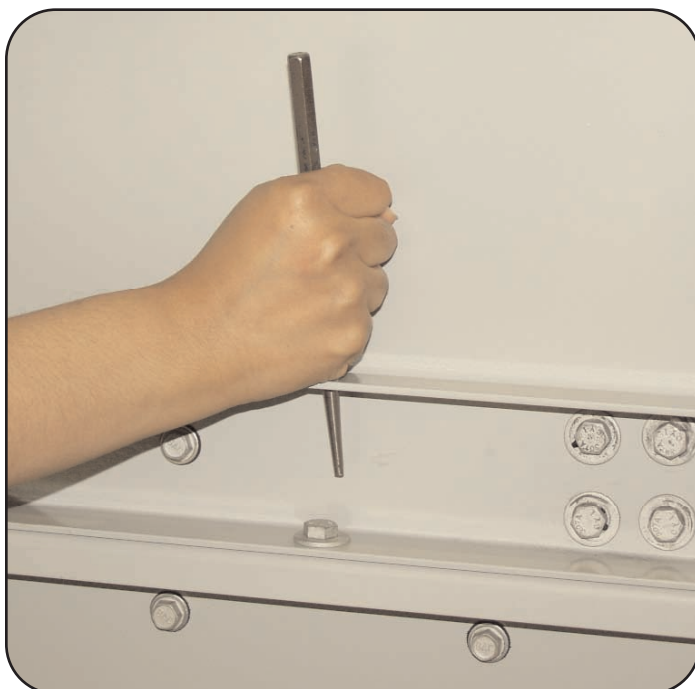

Figure 5

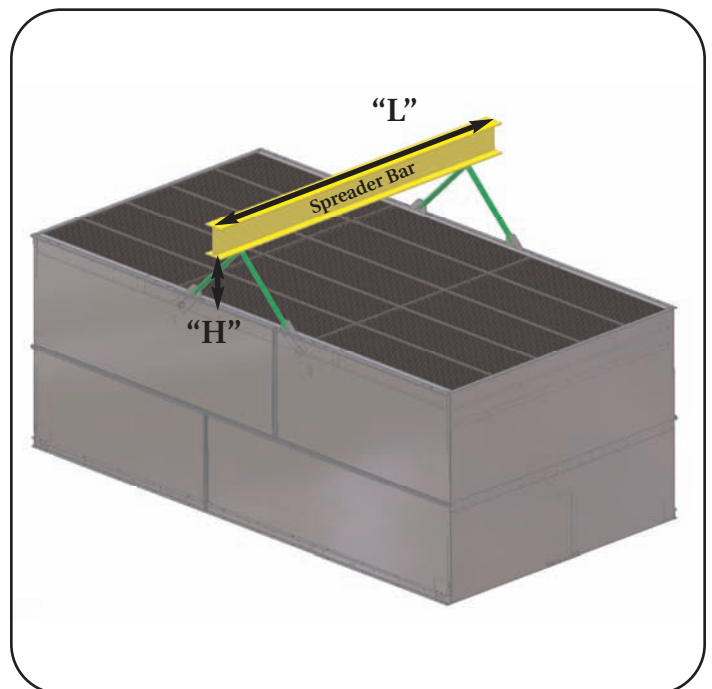

Figure 6

Flume Box Installation

VCA Flume Box Installation

1. Position Cell #1 on the unit support and bolt in place
2. Wipe down the mating surface by the flume opening to remove any dirt or moisture that may have accumulated during shipment
3. Wipe down the flanges on both ends of the flume box. On one end, apply a layer of 1/8" x 1" butyl sealer tape around the face of the flange over the centerline of the holes. Do not over lap or stretch too thinly at the corners. When it is necessary to splice the sealer, be sure to press the two ends together to form a smooth, continuous strip. Apply a second layer of sealer tape over the first layer following the same procedure. Refer to (Figure 8).

4. Using drift pins to align the bolt holes, place the flume box over the opening in the basin of Cell #1 and fasten into place. Insert the 3/8" self-tapping screws or bolts from the flume box into the basin wall as illustrated in (Figure 9) .

Note: Flume boxes furnished with units constructed with stainless steel basins are assembled with stainless steel bolts, washers and nuts in lieu of self-tapping screws.

5. Apply sealer to the other end of the flume box as described in Step 3
6. Position Cell #2 on the unit supports, exactly 1" between casings (Figure 7). Wipe down the mating surface by the flume opening to remove any dirt or moisture.
7. Using drift pins to ensure alignment, draw Cell #2 tight against the flume box

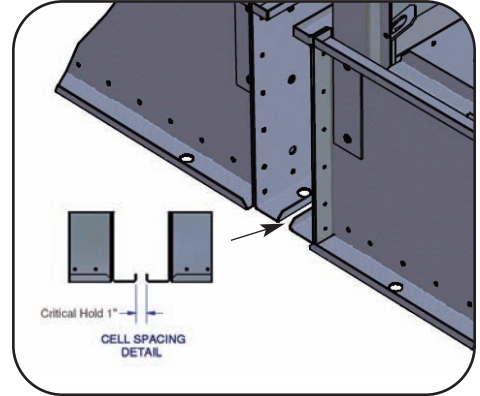

Figure 7

Note: Units equipped with the positive closure plate option, skip step 8 and go to the positive closure plate section of this document.

8. As illustrated in (Figure 9 and 10), insert 3/8" self-tapping screws in each hole from the flume box into the basin wall and tighten.

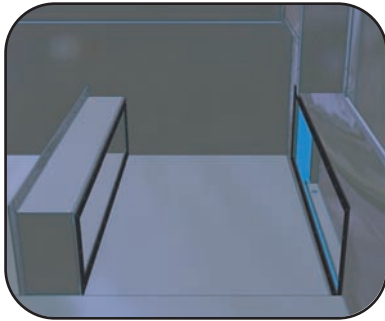

Figure 8

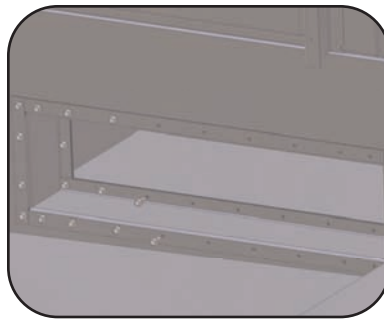

Figure 9

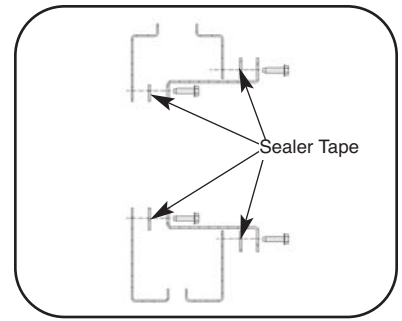

Figure 10

Positive Closure Plate Option

The optional Positive Closure Plate and gasket are furnished on multi-cell units to allow individual cells to be isolated for cleaning and maintenance. The plate ships loose inside the basin. To install the Positive Closure Plate and gasket, follow the steps from the Flume Box Installation section, then complete the installation using the instructions listed.

POSITIVE CLOSURE PLATE INSTALLATION (FIGURES 11 AND 12):

1. Thread 3/8" self-tapping screws from the flume box into the basin wall with the positive closure plate as shown.
2. Position gasket and positive closure plate over the bolts and fasten in place with 3/8" wing nut and flat washers.

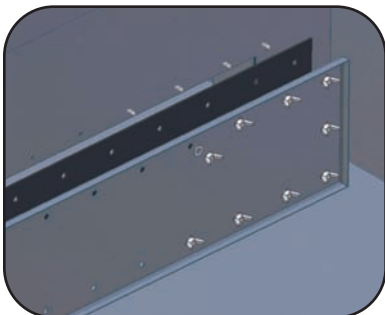

Figure 11

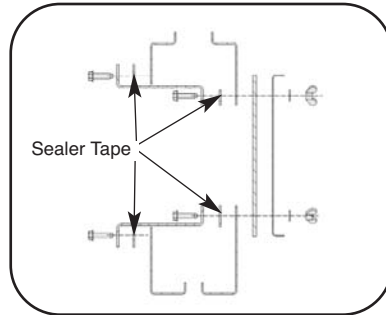

Figure 12

