

END ELEVATION (FACE A)

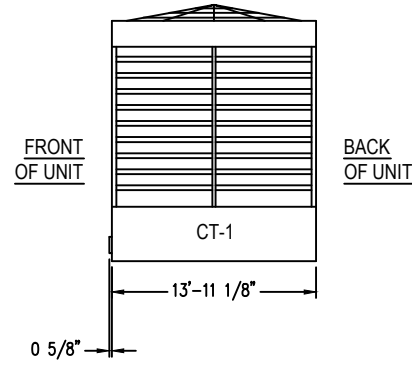

SIDE ELEVATION

Notes

- 1) Drawings are not to scale. All dimensions are in feet and inches. Weights are in pounds and include options and accessories.
- 2) Unless otherwise indicated, connections 3" and smaller are MPT. Connections 4" and larger are grooved to suit a mechanical coupling and beveled for welding.
- 3) Field piping should be fabricated at time of installation. Pre-fabrication of pipe work is not recommended.
- 4) Do not support piping from unit connections. All necessary piping supports to be supplied by others.
- 5) For weight loadings and support requirements, refer to the suggested unit support drawing.
- 6) The area above the fan discharge must be unobstructed.
- 7) Due to height limitations on truck shipments, some items shown may ship loose for field installation.
- 8) Outlet connections are sized for pump suction application at the design flow rate. They are based on the maximum flow rate through the strainer with basin water at standard operating level.

| MODEL NUMBER   | SHIPPING WEIGHT | OPERATING WEIGHT | HEAVIEST SECTION WEIGHT |
|----------------|-----------------|------------------|-------------------------|
| XES3E-1424-07J | 16,169          | 34,206           | 16,169                  |
| XES3E-1424-07K | 16,179          | 34,216           | 16,179                  |
| XES3E-1424-07L | 16,249          | 34,286           | 16,249                  |
| XES3E-1424-07M | 16,269          | 34,306           | 16,269                  |
| XES3E-1424-07N | 16,409          | 34,446           | 16,409                  |
| S3E-1424-07O   | 16,459          | 34,496           | 16,459                  |
| S3E-1424-07P   | 16,619          | 34,656           | 16,619                  |
| S3E-1424-07Q   | 16,629          | 34,666           | 16,629                  |
| S3E-1424-07R   | 16,639          | 34,676           | 16,639                  |

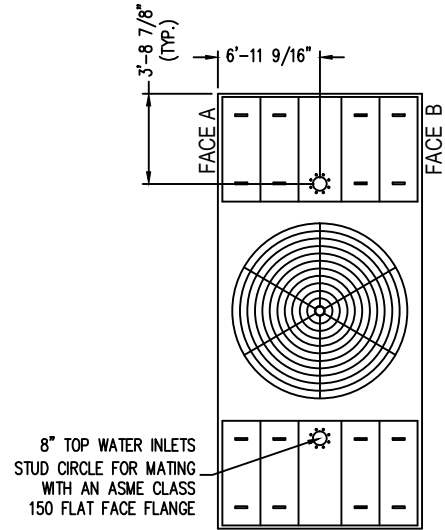

PLAN VIEW

ORDER NO:

DATE: 7/25/2013



**BALTIMORE AIRCOIL COMPANY**

**3000E Unit Print  
One Piece Units**

DRAWING NUMBER:  
**UP-1424-07**