

2000© Baltimore Aircoil Company. All Rights Reserved.

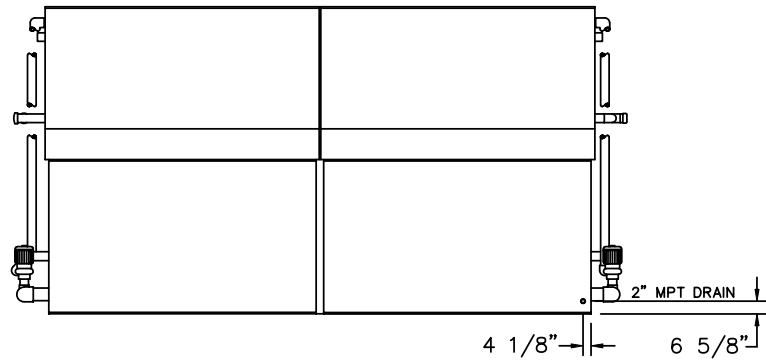
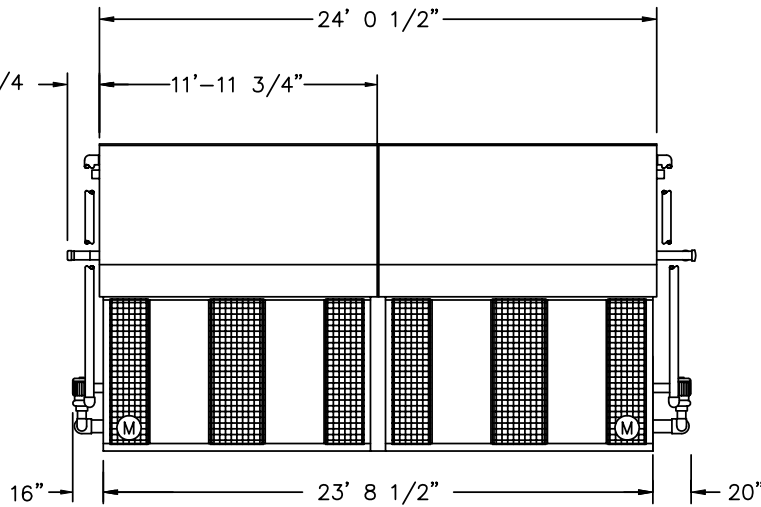
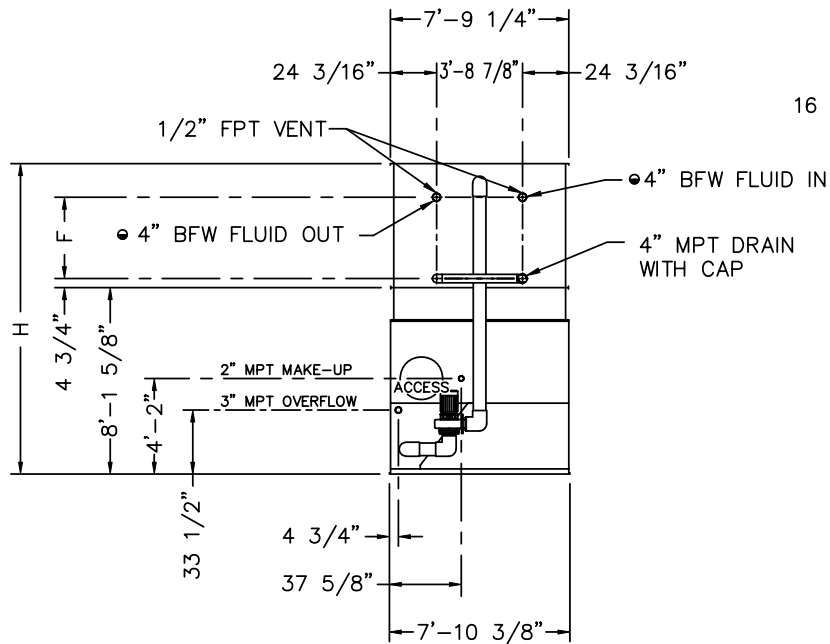

- BFW BEVELED FOR WELDING.
- Ⓜ FAN MOTOR LOCATION.

MODEL NO.	APPROX. SHIPPING WEIGHT	APPROX. OPERATING WEIGHT	HEAVIEST SECTION (COIL)	F	H
VF1-192-32	25570	38900	8460	42 1/2"	13' 6-3/8"
VF1-192-42	28360	42780	9880	51 3/4"	14'-3 5/8"

- NOTES:
- ALL DIMENSIONS ARE IN FEET AND INCHES. WEIGHTS ARE IN POUNDS.
 - UNLESS OTHERWISE INDICATED, ALL CONNECTIONS 6 INCHES AND SMALLER ARE MPT AND CONNECTIONS 8 INCHES AND LARGER ARE BEVELED FOR WELDING.
 - DIMENSIONS SHOWING LOCATION OF COIL CONNECTIONS ARE APPROXIMATE AND SHOULD NOT BE USED FOR PREFABRICATION OF CONNECTING PIPING.
 - SPRAY WATER, OVERFLOW AND COIL CONNECTIONS ARE PROVIDED ON BOTH ENDS OF THE UNIT. ONLY ONE MAKE-UP CONNECTION IS FURNISHED, ON THE END INDICATED.
 - FOR SUPPORT REQUIREMENTS, REFER TO THE SUGGESTED STEEL SUPPORT DRAWING.

B.A.C.
ORDER NO:
DATE:



BALTIMORE AIRCOIL COMPANY

RIGHT HAND UNIT
END OUTLET WITH PUMP
DRAWING NUMBER:
BAC-11736A

-