

NOTES:

1. **Do not use for construction.** Refer to factory certified dimensions.
2. Model number denotes R-717 capacity in evaporator tons at 96.3°F condensing temperature, 20°F suction temperature, and 78°F entering wet bulb temperature.
3. All dimensions are in feet and inches. Weights are in pounds. Volumes are in cubic feet.
4. Operating weight is for the base unit charged with R-717, water level in the cold water basin at overflow, and does not include accessories.
5. The actual size, quantity and location of the coil inlet and outlet connections will vary depending on the refrigerant used and capacity requirements.
6. The coil inlet and outlet connections are NPS beveled for welding as standard.
7. Models with Whisper Quiet fans may have heights up to 5 1/2" greater than shown.

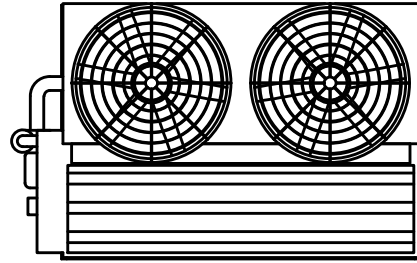

Plan View
Do Not Obstruct Area Above Fans

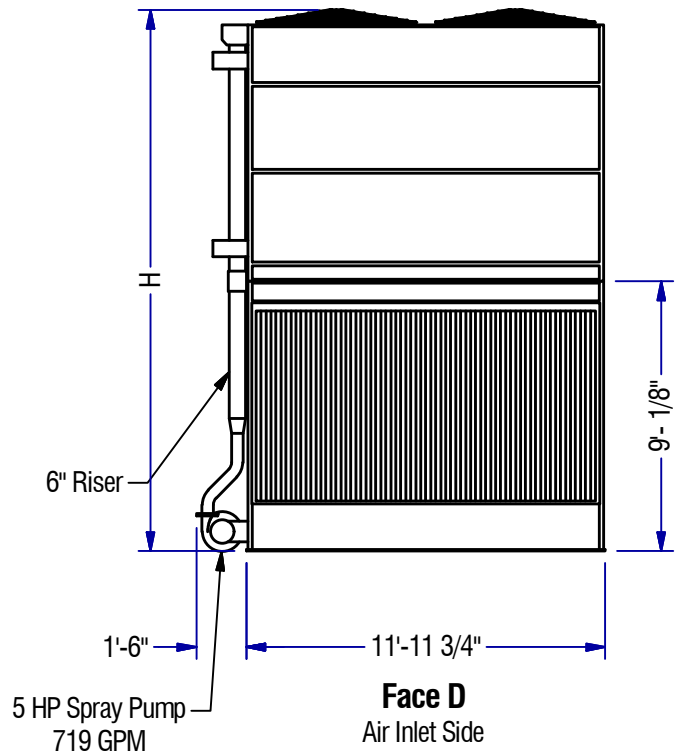
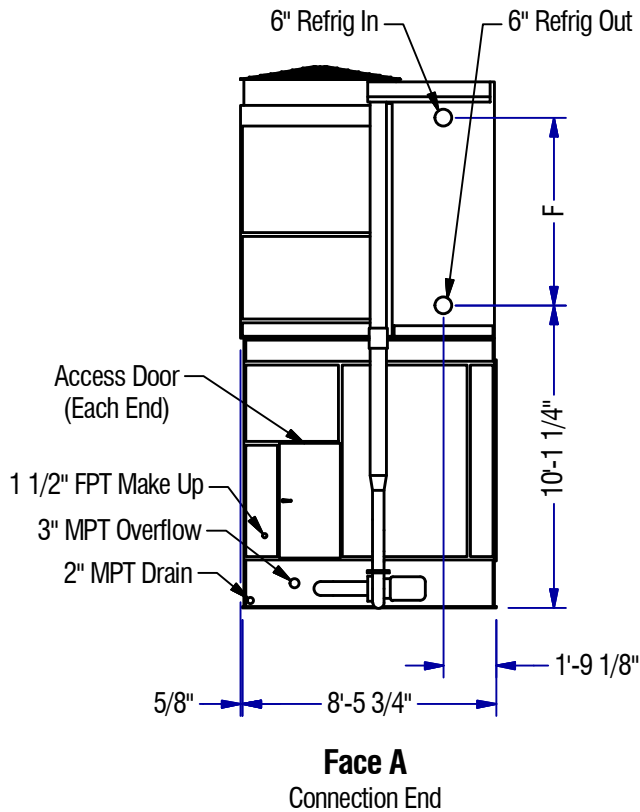

Tabulated Unit Data

Model Number	Fan HP	Operating Wt	Shipping Wt	Heaviest Section	F	H	Coil Volume (FT ³)
CXVB-216-0812-7.5	7.5	16,370	10,920	6,810	6' 3 1/4"	18' 0 7/8"	24
CXVB-221-0812-7.5	7.5	17,310	11,810	7,650	6' 3 1/4"	18' 0 7/8"	30
CXVB-226-0812-7.5	7.5	18,250	12,690	8,500	6' 3 1/4"	18' 0 7/8"	36
CXVB-237-0812-10	10	17,320	11,820	7,670	6' 3 1/4"	18' 0 7/8"	30
CXVB-241-0812-10	10	18,260	12,700	8,510	6' 3 1/4"	18' 0 7/8"	36

CXVB Evaporative Condenser
Tabulated Unit Print

BALTIMORE AIRCOIL COMPANY

Drawing Number:
CXVB-0812B-6-TUP

Rev:
-