

FACE A

FACE B

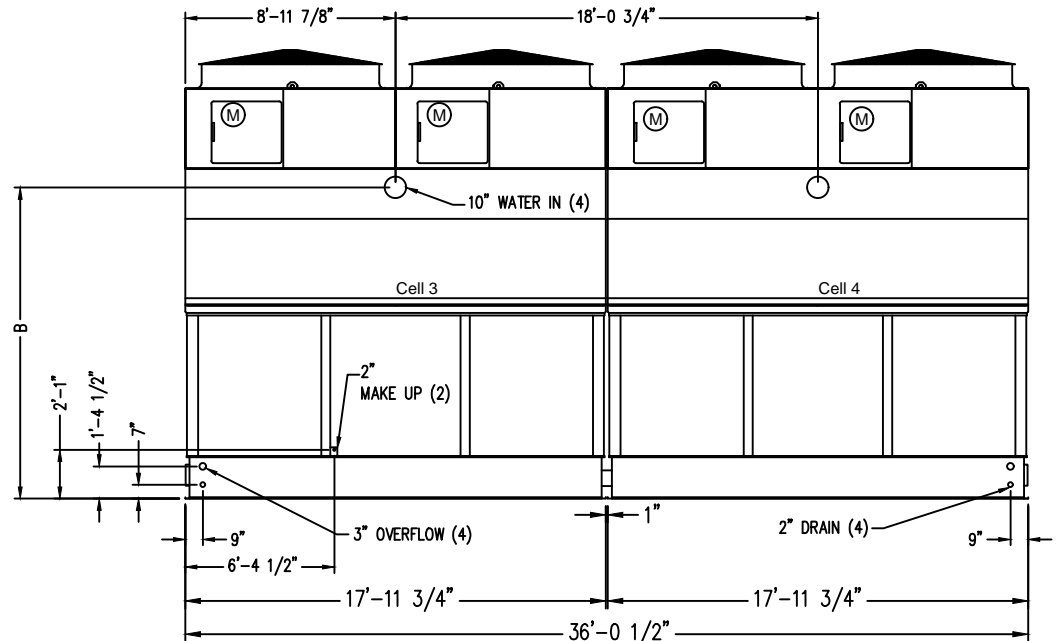

FACE C

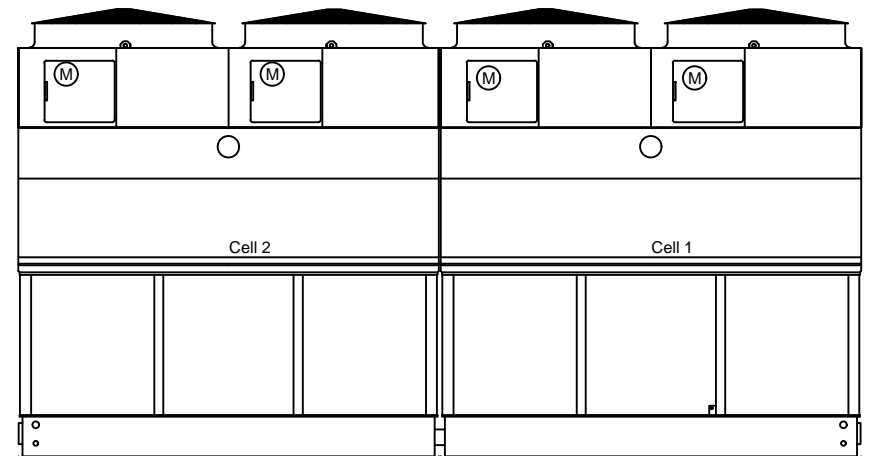

FACE C

Notes

- 1) Unless otherwise indicated, connections 3" and smaller are NPT. Connections 4" and larger are grooved to suit a mechanical coupling and beveled for welding.
- 2) All dimensions are in feet and inches. Weights are in pounds and include options and accessories.
- 3) For weight loadings and support requirements, refer to the suggested steel support drawing.
- 4) The area above the fan discharge must be unobstructed.
- 5) Piping must not be supported by the tower inlet or outlet connections.
- 6) Unit weights include selected accessories.
- 7) M = Motor location.
- 8) Heaviest section is a cell's mechanical section mounted to fill casing section.

Model Number	Shipping Weight	Operating Weight	Heaviest Section	"H"	"B"	"D"	"L"
PT2-1218A-1x4	43750	81300	6920	17'-6 3/8"	11'-3 5/8"	8'-7 7/8"	8'-3 5/8"
PT2-1218A-2x4	46550	84100	7615	18'-6 3/8"	12'-3 5/8"	9'-7 7/8"	8'-3 5/8"
PT2-1218A-3x4	48800	86350	8180	19'-6 3/8"	13'-3 5/8"	10'-7 7/8"	8'-3 5/8"
PT2-1218A-4x4	49790	87890	8180	21'-2 3/8"	14'-11 5/8"	10'-7 7/8"	9'-11 5/8"
PT2-1218A-5x4	57174	95824	9751	21'-10 1/2"	15'-11 5/8"	11'-7 7/8"	9'-11 5/8"

ORDER NO:

DATE:



BALTIMORE AIRCOIL COMPANY

**Unit Print
PT2 Quad Cell 24'x36'**

DRAWING NUMBER: