



TrilliumSeries™

Adiabatic Cooler - TRF

OPERATION & MAINTENANCE MANUAL





TrilliumSeries™ Adiabatic Cooler - TRF

OPERATION & MAINTENANCE MANUAL

Contents

1. Recommended Maintenance Intervals.....	7
2. Parts Map.....	8
Recommended Spare Parts	9
3. Warnings & Cautions	10
Safety Precautions	10
Equipment Precautions	11
4. General Information	12
Adiabatic Cooling	12
Methods of Operation	13
Adiabatic Operation	13
Dry Operation	14
Adiabatic Switchpoint	14
Operating Modes	14
Default	14
Energy Saver	14
Water Saver	14
Load Limiting Modes	15
Night Quiet	15
Night Dry	15
Schedule Dry	15
Maintenance Modes	15
Coil Clean	15
Pad Clean	15
Complete Drain and Dry	15
5. Water Quality	16
Process Fluid Water Quality	16
Adiabatic Pre-Cooler Water Quality	16
Biological Control	17
6. Cold Weather Operation	18

- About Cold Weather Operation 18
- Coil Freeze Protection 18
- Minimum Operation 18
- Emergency Coil Drain 19
- Pre-Cooler Freeze Protection 19
- Protection of Electrical Components 19
- 7. Component Information & Maintenance 20
- Make-Up Water** 20
- General 20
- Make-up Water Connection 21
- Pressure Reducing Valve 21
- Solenoid Valve 22
- Constant Flow Valve 22
- Adiabatic Pre-Cooler Pads 22
- General 22
- Scaling and Fouling 23
- Adiabatic Pre-Cooler Pad Removal 23
- Water Distribution System 25
- General 25
- Sump Access Door (if equipped) 26
- Upper Water Distribution Channel 27
- Lower Water Collection Channel 28
- Sump Strainer (if equipped) 28
- Recirculation Pump 29
- Sump Water Level Radar Sensor (if equipped) 30
- Fan and Motor 33
- General 33
- Fan Types 33
- Minimum Fan Speed 34
- BAC Part Number 251299, Fan and Motor Removal & Installation 35
- BAC Part Number 251317 EC Fan and Motor Assembly Removal & Installation 41
- Finned Coil Heat Exchanger 48
- Control Panel 49
- Thermostat Settings 49
- Control Panel Ventilation 49

- 8. Control Logic.....50
- Sequence of Operation Diagram 51**
- 9. User Interface52
- Home Menu 52**
- Access Levels 53**
- Changing Password 53**
- Overview Menu 54**
- Fan Menu..... 56**
- All Fans Menu 57**
- All Fans Analog Menu 58**
- All Fans Alarms Menu 58**
- All Fans Manual Menu 59**
- Fan X Manual..... 61**
- Setpoints 62**
- Leaving Fluid Control & Customer Input Control Menu 62**
- Basin Water Quality Menu 64**
- Maintenance Menu 73**
- Technician Menu..... 76**
- Input & Output 79**
- Temperatures Menu 79**
- Make Up Menu 80**
- Basin Water Level Menu..... 80**
- Pumps Menu..... 81**
- Starts and Hours Menu 81**
- Manual Menu 84**
- Alarms 85**
- Alarm Details Page 86**
- Settings..... 87**
- Setup Menu 87**
- Modbus RTU Setup..... 89**
- BACnet MSTP Setup 90**
- Modbus TCP Setup..... 91**
- BACnet IP Setup 93**
- Software Version Menu..... 94**
- Hardware Configuration Menu..... 95**

Technician Menu	96
10. Unit Operation & Storage.....	101
General	101
Corrosion Protection	101
Inspection	102
Cleaning	102
Start-up	103
Control Panel	103
Control Settings	103
Component Operation	104
Extended Shutdown	105
11. Alarms & Troubleshooting.....	106
Fan Alarms & Troubleshooting	112
Unit Alarm Codes	115
Fan Alarm Codes	116
12. BMS Communication	117
BACnet IP & Modbus TCP	117
Modbus RTU Communications, Points List	117
BACnet Communications, Points List	136
Appendix A - PLC Hardware Part # 313978	148
Replacing PLC Battery for units using part number	148
Appendix B– User Interface Part # 313976.....	152
Home Menu	152
Access Levels	153
Overview Menu	154
Fan Menu	156
All Fans Menu - Overview	157
All Fans Menu – Analog Data	158
All Fans Menu – Alarms	159
Fan X Menu	162
Setpoints	163
Leaving Fluid Control & Customer Input Control Menu	164
Basin Water Quality Menu	167
Load Limiting Menu	168
Maintenance Menu	174

Technician Menu..... 177

Input & Output 178

Temperatures Menu 178

Make Up Menu 180

Pumps Menu..... 181

Basin Water Level Menu..... 182

Starts and Hours Menu 183

Manual Menu 185

Alarms 187

Alarm Details Page..... 188

Settings..... 189

Setup Menu 189

Modbus RTU Setup..... 191

BACnet MSTP Setup 192

Modbus TCP Setup..... 194

BACnet IP Setup 195

Software Version Menu..... 197

Technician Menu..... 200

Data Logging Retrieval 202

Readdress New Fan 205

Headless HMI..... 206

Appendix C – Alarms Part #313976 207

Fan Alarms & Troubleshooting, BAC Part Number 251299 212

Fan Alarms & Troubleshooting, BAC Part Number 251317 215

Unit Alarm Codes 219

Fan Alarm Codes 220

Appendix D – Points List Part #313976 221

Modbus RTU Communications, Points List..... 221

BACnet Communications, Points List..... 234

1. Recommended Maintenance Intervals

Inspect and clean as necessary ^[1] :	Start-Up	Monthly	Quarterly	Semi Annually	Annually
Inspect general condition of the unit and check unit for unusual noise or vibration					

¹ Recommended service intervals are the minimum for typical installations. Harsh environmental conditions may dictate more frequent servicing.

² To prevent excessive degradation, do not attempt to remove the adiabatic pre-cooler pads in a wet state.

³ Refer to **Table 8** or minimum filter material replacement intervals.

2. Parts Map



1	Coils	10	Integrated Control Panel
2	Fans with Integrated EC Motor Kit	11	Lower Water Collection Channel
3	Adiabatic Pre-Cooler Pads	12	Sump Access Door
4	Water Distribution Inspection Cover	13	Sump Strainer (if equipped)
5	Upper Water Distribution System	14	Drain Valve Access Cover
6	Plenum Access (on opposite face, not shown)	15	Recirculation Pump
7	Pressure Reducing Valve	16	Float Switch (if equipped)
8	Make Up Valve	17	Drain Valve
9	Constant Flow Valve	18	Overflow
		19	Radar Sensor (if equipped)

Recommended Spare Parts

BAC Factory Authorized Parts are manufactured to meet rigorous specifications and are guaranteed to fit your unit and perform as original equipment. BAC Factory Authorized Parts can be ordered through your local BAC Representative. Most BAC Representatives maintain a local inventory of commonly used parts. For a free unit inspection and a specific parts list for your serial number, contact your [local BAC Representative](#) today. Even with BAC's fast delivery capability, it is still recommended that certain essential and emergency repair part be maintained in your inventory to minimize any potential downtime.

Basic Recommended Spare Parts	Parts to Consider if Extended Downtime is a Concern
Recirculation Pump	Adiabatic Pre-Cooler Pad Kit
Float Switch (if equipped)	Fans with Integrated EC Motor Kit
Make-up Valve	
Pressure Reducing Valve	
Drain Valve	
Strainer	

3. Warnings & Cautions

Safety Precautions

- **⚠ DANGER**: This unit contains rotating equipment that can cause severe personal injury or death upon contact. Never remove or step on a fan guard grill, subject the fan guard grill to load, or place any objects on the fan guard grill. Employ safeguards (including the use of protective enclosures where necessary) to prevent public access to equipment.
- **⚠ DANGER**: Performing work on an energized unit poses a risk of electrocution, which can cause severe personal injury, death, and/or property damage. Do not perform any service on or near the unit without first ensuring the unit is de-energized and all lockout / tagout procedures have been followed. Wait five minutes after disconnecting the voltage at all poles before opening the fan and motor assembly.
- **⚠ WARNING**: In rare circumstances, chemicals or biological contaminants may be introduced into the recirculating water system that could result in personal injury if inhaled or ingested. Wear appropriate respiratory protection when exposed to the discharge air stream or to the mists produced by cleaning activities associated with the recirculating water system or adiabatic pre-cooler pads.
- **⚠ WARNING**: Do not use the top horizontal surface of the unit as a walking surface or a working platform. Doing so poses a risk of falling through the surface, resulting in personal injury and/or equipment damage.
- **⚠ CAUTION**: The surface of the fan motor electronics housing can get very hot and pose the risk of burns. Wear appropriate PPE to ensure sufficient protection against accidental contact with the fan motor housing.

Equipment Precautions



NOTE

- While transporting the fan, wear safety shoes and cut-resistant safety gloves to prevent injuries from tipping or slipping. The fan is only to be transported lying flat (i.e. the motor axis must be vertical) in its original packaging. Secure the fan(s) (e.g., with a lashing strip) to stop anything from slipping or tipping while transporting the fan.
- Do not open or recharge the battery located in the control panel PLC. Doing so may cause an explosion, resulting in personal injury.
- Drain all water piping feeding the adiabatic pre-cooler to avoid stagnant water conditions.
- Water hammer is a common reason for pressure-reducing valve failures. Systems with risk of water hammer will require the installation of protective devices—such a water hammer arrestor or shock absorber -- to absorb water hammer.
- The adiabatic pre-cooler pads are made of flammable material and should be removed when performing hot work on or near the unit. No actions that generate sparks should be performed on or near the unit.
- Do not run the unit wet with the adiabatic pre-cooler pads removed and the fans on. Wet/dry cycling of the unit in this manner will cause the coils to get wet and could shorten the coil life and void the warranty.
- To prevent excessive degradation, do not attempt to remove the adiabatic pre-cooler pads in a wet state.
- For PLC part number 313978, replace battery with R/C (BBCV2), Part. No. CR2032, rated 3V only. Use of an incorrect battery type may present a risk of fire or explosion.
- Scratches on the control panel PLC motherboard may cause the motherboard to fail. Exercise care with the battery replacement lever and avoid scratching the motherboard on PLC part number 313978.
- Changing the controller's parameters may result in an undesired operation of the unit, such as a hunting phenomenon, premature activation of pre-cooling (and increased water consumption) or delayed pre-cooling activation (fluid outlet temperatures exceeding the design temperature). For further questions, contact BAC.
- Never use chloride or chlorine-based solvents such as bleach or muriatic (hydrochloric) acid to clean stainless steel. It is important to rinse the surface with warm water and wipe with a dry cloth after cleaning.
- Do not use steam, high-pressure water, or high-pressure air to clean any component

4. General Information

Adiabatic Cooling

Adiabatic cooling uses evaporation to cool air before it passes through a finned heat exchanger. During adiabatic cooling, a wetted pad is used to cool the entering airstream. The pads are specially designed to retain water on the surface to ensure that it does not carry over to the finned coil, minimizing the risk of coil damage. The finned heat exchanger stays dry, protecting surfaces from scale and corrosion.

The use of a small amount of water to pre-cool the air entering the heat exchanger lowers the required airflow and fan power compared to air-cooled units, while also lowering the fluid temperature back to the system. In the most efficient adiabatic systems, the air is cooled close to the wet-bulb temperature. Such substantial depression of the air temperature results in a significant increase in dry cooling capacity and energy efficiency compared to dry-only designs. Once the ambient temperature begins to approach freezing, or during times of reduced load, the unit can be switched to operate in a dry-only mode, thus decreasing water usage.

Adiabatic heat rejection system controls are designed to be flexible, intelligent, and customer friendly, taking full advantage of the dual operating modes. At a customer-selected design point, such as a cooler ambient dry bulb and a lower heat load, the unit can turn off the recirculating water and switch to operation in dry mode. Additionally, the low volume recirculating water sump automatically drains when freezing temperatures are experienced, negating the need for sump heaters.

The recirculating design of an adiabatic heat rejection system consumes less water than an evaporative cooling tower and an adiabatic cooler with a “once through” design that sends water directly to the drain.

Methods of Operation

Adiabatic Operation

As illustrated in **Figure 1**, when the unit operates in adiabatic mode, either the make-up water connection or the recirculation pumps supply water over the adiabatic pre-cooler pads. Incoming air is humidified as it passes through the adiabatic pre-cooler pads, cooling the air down close to the ambient wet bulb temperature. This cooled air passes over the coil and cools the process fluid in the coil, which returns to the system. In the sump, pumps recirculate the water back over the pads. Part of the recirculated water is evaporated while the excess water assists in rinsing the adiabatic pre-cooler pads. The unit controls determine when the water is purged from the sump and new make-up water enters.

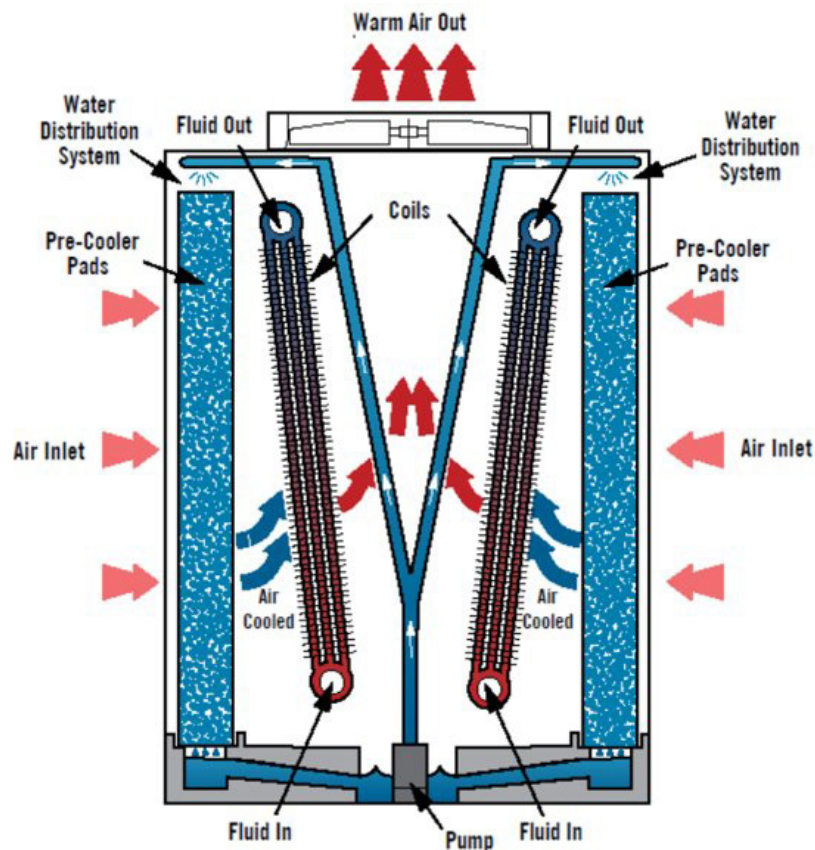

Figure 1. Adiabatic Operation

Dry Operation

As illustrated in **Figure 2**, when the unit operates in dry mode, ambient air cools the process fluid in the coils, which then returns to the system. The unit operates in dry mode when the ambient dry bulb temperature is less than the adiabatic switchpoint temperature.

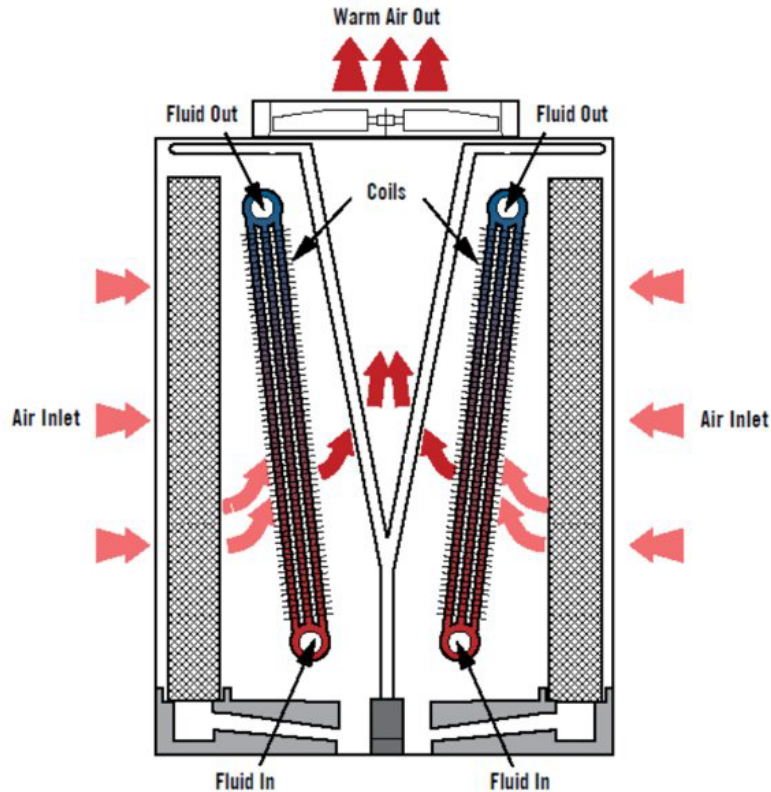

Figure 2. Dry Operation

Adiabatic Switchpoint

The adiabatic switchpoint temperature, also referred to as dry switchpoint temperature, is the ambient dry bulb temperature at which the unit transitions from dry operation to adiabatic operation. Once the ambient temperature reaches the switchpoint, the recirculating pumps turn on to pre-cool the intake air.

Operating Modes

Default

The Default mode utilizes factory set operating parameters that balance water and energy savings. Refer to **Table 14** for more information.

Energy Saver

The unit is equipped with Energy Saver mode, which can be enabled at any time. This mode optimizes the operating parameters to save energy. Energy Saver mode will enter adiabatic operation more quickly than Default or Water Saver modes, resulting in lower fan power energy consumption. Refer to **Table 14** for more information.

Water Saver

The unit is equipped with Water Saver mode, which can be enabled at any time. This mode optimizes the operating parameters to save water. Water Saver mode will cause the unit to stay in dry operation longer than Default or Energy Saver modes, resulting in lower water consumption. Refer to **Table 14** for more information.

Load Limiting Modes

Night Quiet

Night Quiet load limiting mode will reduce sound levels of the unit overnight. When active, the Night Quiet feature limits the maximum fan speed. The Night Quiet feature can be activated on the touchscreen, through the BMS, or by a schedule, so that the user can define a start time on one day and a stop time on the next day. All times are in a 24-hour format.

Night Dry

Night Dry load limiting mode will prevent adiabatic operation of the unit overnight and can be activated by a schedule, so that the user defines a start time on one day and a stop time on the next day. All times shall be in 24-hour format.

Schedule Dry

Schedule Dry load limiting mode prevents adiabatic operation during the day and can be activated by a schedule, so that the user defines a start time on one day and a stop time on the same day. All times shall be in 24-hour format.

Maintenance Modes

Coil Clean

Coil Clean is a scheduled maintenance mode that will remove loose debris from the coil surface, ensuring maximum energy efficiency. Coil clean reverses fan rotation and airflow while opening the make-up and drain valve if the outside air temperature is greater than 40°F (4°C) to flush debris down the drain.

Pad Clean

Pad Clean is a scheduled maintenance mode that removes loose debris from the adiabatic pre-cooler pad surface, ensuring maximum energy efficiency. Pad clean will open the make-up and drain valves to flush the pads with clean water.

Complete Drain and Dry

Complete Drain and Dry is a scheduled maintenance mode that fully drains the sump and dries out the adiabatic pre-cooler pads.

5. Water Quality

Process Fluid Water Quality

To prevent excessive fouling and internal coil corrosion, the recirculating water quality should remain within the limits indicated in **Table 1**. A qualified and well-rated water treatment company should be consulted for the specific water treatment to be used that is suitable for all materials of construction used in the entire system. For higher pH levels, it is recommended to add a specific copper corrosion inhibitor such as TT or BZT with a target residual concentration of above 2 ppm (multiple dosages might be required).

Variable	Copper
pH	6.5 -10.5
Hardness (as CaCO ₃)	0-500 mg/l
Alkalinity (as CaCO ₃)	0-500 mg/l
Conductivity	< 3300 µS/cm
Chlorides	< 250 mg/l
Total suspended solids	< 10 mg/l
COD (chemical oxygen demand)	< 50 ppm

Table 1. Heat Exchanger Circulated Water Quality

Adiabatic Pre-Cooler Water Quality

⚠ WARNING: In rare circumstances, chemicals or biological contaminants may be introduced into the recirculating water system that could result in personal injury if inhaled or ingested. Wear appropriate respiratory protection when exposed to the discharge air stream or to the mists produced by cleaning activities associated with the recirculating water system or adiabatic pre-cooler pads.

To control corrosion and scale, the water chemistry of the adiabatic pre-cooler water must be kept within BAC's water quality guidelines available at baltimoreaircoil.com. Material of construction for the TrilliumSeries™ Adiabatic Cooler – TRF is thermosetting hybrid polymer.

The primary water treatment control method for the adiabatic pre-cooler is to provide sufficient water to the pre-cooler medium to keep it flushed. If sufficient water is not provided to completely wet and flush the entire pre-cooler medium surface, deposits of minerals will occur. Adiabatic pre-cooler water quality should be of potable supply. In the case of non-treated water, the temperature should be kept below 68°F (20°C).

The sump will automatically drain when a maximum cycle of concentration is reached. The unit can also be set up to periodically drain the sump and dry the adiabatic pre-cooler pads. These features reduce the risk of microbiological contamination. Check your local codes and regulations for water treatment requirements.

The drained water may be suitable for non-potable use such as irrigation. Refer to local codes and regulations to determine allowable uses.

In applications where hard water is supplied to the unit, a water softener may extend the life of the adiabatic pre-cooler pads.

The adiabatic pre-cooler pads have been treated with an algaecide to minimize the potential for algae growth. In cases where excessive fouling is observed and is suspected to be interfering with the airflow, the adiabatic pre-cooler pads should be cleaned and/or changed more frequently.

Biological Control

The TrilliumSeries™ Adiabatic Cooler has been designed to minimize the risk of uncontrolled growth of algae, slimes, and other micro-organisms such as *Legionella* through:

1. Adjustable sump water retention time to mitigate standing water
2. Complete drying of the pre-cooling system after each adiabatic cycle
3. Complete draining of all water distribution piping installed on the unit after each adiabatic cycle



NOTE: Drain all water piping feeding the adiabatic pre-cooler to avoid stagnant water conditions.

4. Use of potable water supply at temperatures of 68°F (20°C) or less, where *Legionella* is dormant
5. Aerosol free operation

When basic housekeeping practices and the guidelines for operation and maintenance of this bulletin are followed uncontrolled growth of micro-organisms will be avoided.

6. Cold Weather Operation

About Cold Weather Operation

The equipment can be operated in sub-freezing ambient conditions provided that the proper measures are taken. Listed below are general guidelines that should be followed to minimize the possibility of freeze-up. Customers in climates that reach below freezing temperatures should take necessary precautions to protect the water pipes from freezing. This may include installing a valve to prevent standing water in the pipes (supplied by a third-party vendor). It may be necessary to heat trace all exposed make-up water lines if the water cannot be shut off and external piping cannot be drained.

Coil Freeze Protection

For protection against coil freeze-up, recommended process fluid solutions are industrial grade inhibited ethylene glycol or propylene glycol solution. When the use of glycol is not practical, the system must be designed to meet the minimum temperature requirements.

Minimum Operation

When a glycol solution is not utilized, operate the system to maintain a minimum heat load on the process fluid so that the temperature of the fluid leaving the coil is not less than 50°F (10°C). To maintain the leaving fluid temperature at 50°F (10°C) when the process load is extremely light or off, apply an auxiliary heat load to the process fluid and adjust the flow to ensure that fluid leaving the coil maintains the minimum required temperature. **Table 2** lists the rate of heat loss per model number.

Model Number	# of Fans	Heat Loss Data (BTU/HR) ⁴
TRF-1010N-C80XL17E	4	4,515,780
TRF-1010N-C80XS17E	4	4,437,940
TRF-1014N-C80XS26E	6	6,814,040
TRF-1014N-C80XM26E	6	6,739,300
TRF-1018N-C80XM34E	8	8,889,800
TRF-1018N-C80XD34E	8	8,740,240
TRF-1022N-C80XM43E	10	11,044,580
TRF-1022N-C80XD43E	10	10,888,320
TRF-1026N-C80XD51E	12	13,260,240
TRF-1026N-C80XQ51E	12	12,828,280
TRF-1030N-C80XD60E	14	15,634,340
TRF-1030N-C80XQ60E	14	15,187,740
TRF-1034N-C80XD68E	16	17,788,200
TRF-1034N-C80XQ68E	16	17,342,760
TRF-1038N-C80XD77E	18	19,935,680
TRF-1038N-C80XQ77E	18	19,488,920

Model Number	# of Fans	Heat Loss Data (BTU/HR) ⁵
TRF-1010N-C60XS17E	4	4,140,335
TRF-1010N-C60XZ17E	4	4,201,958
TRF-1014N-C60XS26E	6	6,381,006
TRF-1014N-C60XZ26E	6	6,449,589
TRF-1018N-C60XM34E	8	8,270,501
TRF-1018N-C60XS34E	8	8,443,632
TRF-1022N-C60XM43E	10	10,328,624
TRF-1022N-C60XS43E	10	10,505,917
TRF-1026N-C60XT51E	12	12,090,506
TRF-1026N-C60XM51E	12	12,593,043
TRF-1030N-C60XT60E	14	14,339,571
TRF-1030N-C60XM60E	14	14,856,029
TRF-1034N-C60XT68E	16	16,370,738
TRF-1034N-C60XM68E	16	16,911,149
TRF-1038N-C60XT77E	18	18,434,865
TRF-1038N-C60XM77E	18	18,966,474

Table 2. TRF Heat Loss Data

Emergency Coil Drain

Do not drain the coils as a regular method of freeze protection. Draining should only be used as an emergency method of freeze protection. Allowing the coils to freely drain via gravity is insufficient and cannot be relied upon to protect the coils from damage due to freezing. The use of compressed air or an air dryer must be used to ensure all fluid is removed from the coil.

Pre-Cooler Freeze Protection

The integrated controls are set to a default cold weather threshold temperature of 38°F (3.4°C). When the outside air temperature falls below the cold weather threshold temperature, the unit will automatically transition into dry mode of operation and the sump drain valve will open. The control panel will automatically disable adiabatic operation when the outside air temperature is below the cold weather threshold temperature.

Protection of Electrical Components

To protect the electrical components from cold weather, the electrical panel is equipped with a heater to prevent the temperature inside the panel from dropping below 40°F (4.4°C).

⁴ Heat loss data based on 102°F (39°C) entering coil water, nominal unit flowrate (with water) and -10°F (-23°C) ambient air temperature with a 45MPH (72 km/hr) wind velocity. Fans and pump are off.

7. Component Information & Maintenance

⚠ DANGER : This unit contains rotating equipment that can cause severe personal injury or death upon contact. Never remove or step on a fan guard grill, subject the fan guard grill to load, or place any objects on the fan guard grill. Employ safeguards (including the use of protective enclosures where necessary) to prevent public access to equipment.

⚠ DANGER : Performing work on an energized unit poses a risk of electrocution, which can cause severe personal injury, death, and/or property damage. Do not perform any service on or near the unit without first ensuring the unit is de-energized and all lockout / tagout procedures have been followed. Wait five minutes after disconnecting the voltage at all poles before opening the fan and motor assembly.

Make-Up Water

General

A minimum water flow must be distributed over the adiabatic pre-cooler pads during adiabatic operation. Make-up flow rates are listed in **Table 3**. Proper flow is preset using a pressure reducing valve and constant flow valve, as shown in **Figure 3**.

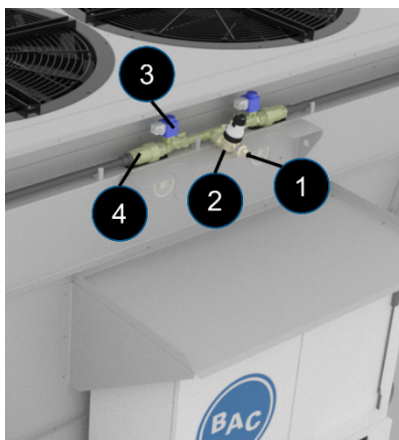

- 1 Make-up water connection (qty. 1)
- 2 Pressure reducing valve (qty. 1)
- 3 Solenoid valve (qty. 2)
- 4 Constant flow valve (qty. 2)

Figure 3. Make-Up Water Connection Detail

Model Number	# of Fans	Make-up Water Flow Rate	
		GPM	L/min
TRF-1010N-C80XX17E	4	5.3	20
TRF-1014N-C80XX26E	6	7.9	30
TRF-1018N-C80XX34E	8	10.6	40
TRF-1022N-C80XX43E	10	13.2	50
TRF-1026N-C80XX51E	12	15.9	60
TRF-1030N-C80XX60E	14	18.5	70
TRF-1034N-C80XX68E	16	21.2	80
TRF-1038N-C80XX77E	18	23.8	90

Model Number	# of Fans	Make-up Water Flow Rate	
		GPM	L/min
TRF-1010N-C60XX17E	4	5.3	20
TRF-1014N-C60XX26E	6	7.9	30
TRF-1018N-C60XX34E	8	10.6	40
TRF-1022N-C60XX43E	10	13.2	50
TRF-1026N-C60XX51E	12	15.9	60
TRF-1030N-C60XX60E	14	18.5	70
TRF-1034N-C60XX68E	16	21.2	80
TRF-1038N-C60XX77E	18	23.8	90

Table 3. Make-up Water Flow Rate per Model Number

Make-up Water Connection

Refer to the unit submittal package for specific water line connection type, size, and location.

Pressure Reducing Valve

The adjustable pressure-reducing valve sets the make-up water pressure. The valve must be protected against freezing by heat tracing all exposed make-up water lines if the water cannot be shut off and external piping cannot be drained.

The pressure reducing valve is factory set at 45 psi (3 bar) for all TRF model numbers. To verify this setting, see the pressure setting indicator that is visible on both sides of the valve. An adjustment lock screw is located at the top of the set point knob. See **Figure 4** for details. Shut off isolation valves (this is typically done by others) before adjusting the pressure setting of the valve.

Inspect and clean the cartridge at least every 12 months. When checking, cleaning, or replacing the cartridge:

1. Shut off isolation valves (this is typically done by others).
2. Remove the cartridge shown in **Figure 5** and clean the stainless-steel filter.
3. Reinstall following same procedure.

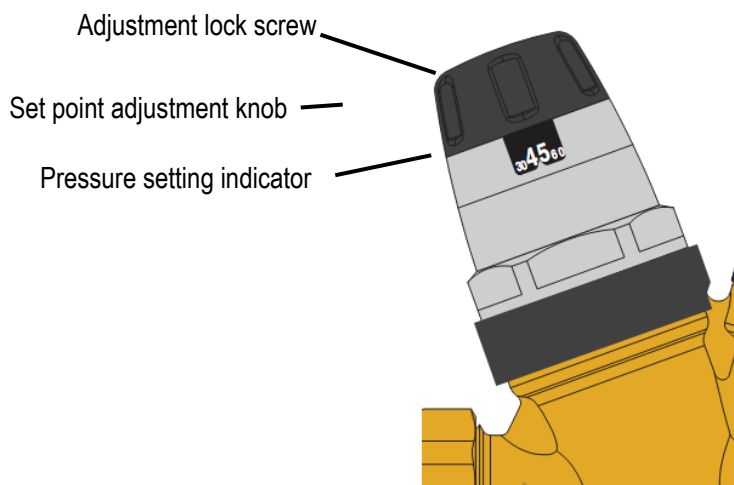

Figure 4. Pressure Reducing Valve

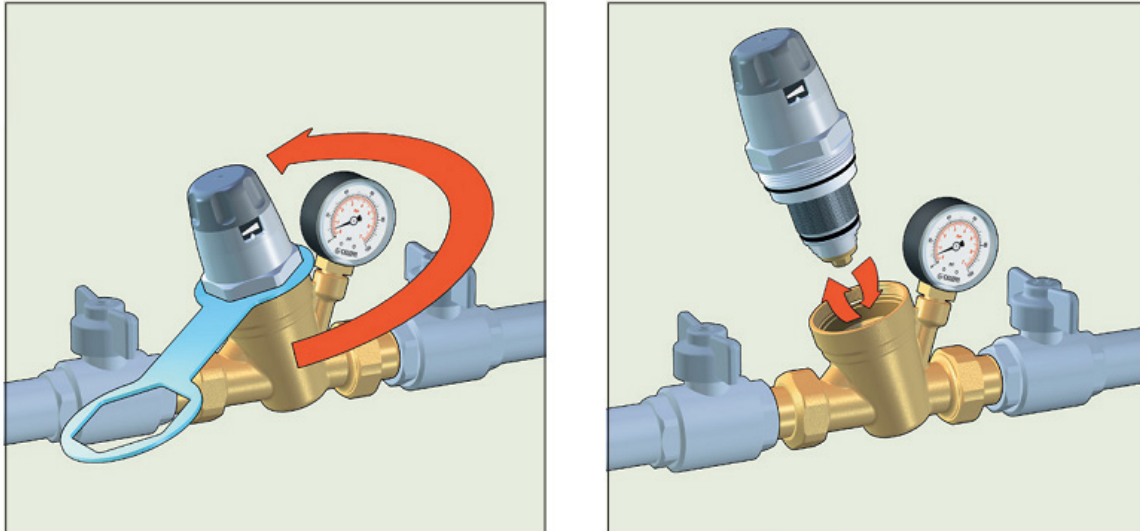

Figure 5. Removal of Self-Contained Cartridge



NOTE: Water hammer is a common reason for pressure-reducing valve failures. Systems with risk of water hammer will require the installation of protective devices—such a water hammer arrestor or shock absorber -- to absorb water hammer

Solenoid Valve

The solenoid valve is normally closed (fail closed) and slow closing to prevent water hammer. This device is not adjustable and does not have any service or maintenance requirements.

Constant Flow Valve

This device automatically sets the water flow rate. This device is not adjustable and does not have any service or maintenance requirements.

Adiabatic Pre-Cooler Pads

General

Adiabatic pre-cooler pads are saturated with water during adiabatic mode of operation. Adiabatic pre-cooler pads cool entering air before it reaches the coil. The pads have an integrated distribution section that accepts water sprayed unevenly on top surface and distributes it evenly across the pad. The air inlet face of the adiabatic pre-cooler pad is protected by a blue anti-stick coating that protects against algae growth and UV damage.



NOTE: The adiabatic pre-cooler pads are made of flammable material and should be removed when performing hot work on or near the unit. No actions that generate sparks should be performed on or near the unit.



NOTE: Do not run the unit wet with the adiabatic pre-cooler pads out and the fans on (thereby getting the coils wet). Wet/dry cycling of the unit in this manner could shorten the coil life and void the warranty.

Scaling and Fouling

Airborne debris is caught by the adiabatic pre-cooler pads, which act as air filters and protect the heat exchanger coil from fouling. During adiabatic mode of operation, the pads are rinsed by the recirculating water. The debris that is rinsed from the pads drains with the excess water. The adiabatic pre-cooler pads should be inspected monthly for the following:

- Signs of excessive fouling and scaling
- To ensure full and even wetting of the face area, while in adiabatic mode of operation

To maintain the adiabatic pre-cooler pads, enable the self-clean cycle for daily cleaning operation. Refer to **Maintenance Menu** section on **Page 73** for more details. If excessive dust, debris, scale, etc. has accumulated on the adiabatic pre-cooler pads, it is recommended to wash the pads by removing them from the unit and rinsing them using a standard garden hose at a downward angle. Continue rinsing until water flows freely to the other side. Never use a brush or a high-pressure hose for cleaning the adiabatic pre-cooler pads. Scale may deposit when the pads dry at the end of each adiabatic cycle. The rate of scaling will depend on:

- The number of adiabatic mode starts and stops
- Water quality
 - To reduce the amount of scaling on the adiabatic pre-cooler pads due to poor water quality, set a lower cycles of concentration drain value. Refer to the **Basin Water Quality Menu** on **Page 64** for more information.
- Poor air quality and airborne debris.

Adiabatic Pre-Cooler Pad Removal



NOTE: To prevent excessive degradation, do not attempt to remove the adiabatic pre-cooler pads wet.

Adiabatic pre-cooler pads are designed for tool-free removal for ease of maintenance and quick access to the interior of the unit for inspection. To remove the adiabatic pre-cooler pads:

1. Remove the adiabatic pre-cooler pad wedge by removing two plastic knobs per wedge assembly. A 4-fan unit will have two pad wedges; a 6-10 fan unit will have four pad wedges; a

12-fan unit will have six pad wedges and a 14-18 fan unit will have eight pad wedges. Refer to **Figure 6** for typical wedge locations.

2. Reposition the adiabatic pre-cooler pad wedge and grip both sides of the pad. Lift the pad directly up and then towards you.

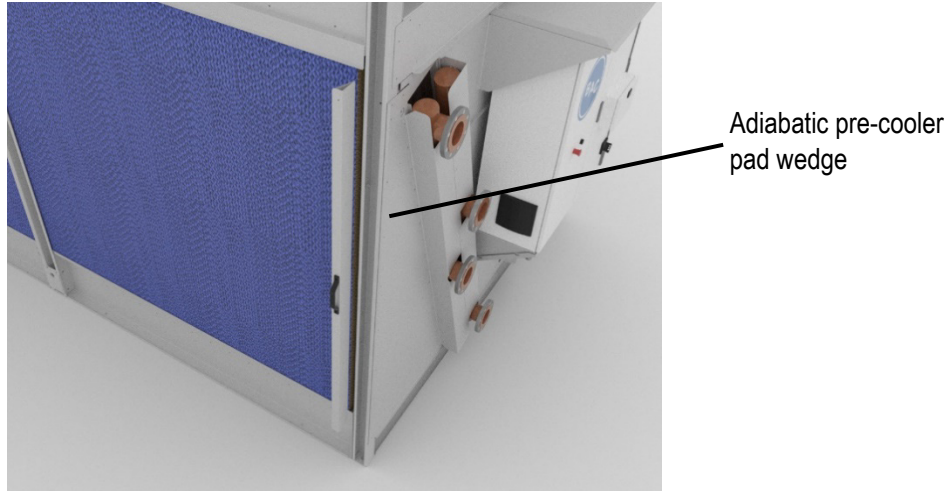

Figure 6. Adiabatic pre-cooler pad wedge

3. Reinstall the adiabatic pre-cooler pads in the reverse order of removal. Always re-install the adiabatic pre-cooler pads with the blue protective coating on the outside face. Always ensure that the re-distribution section of the pad is at the top of the unit per **Figure 7**.

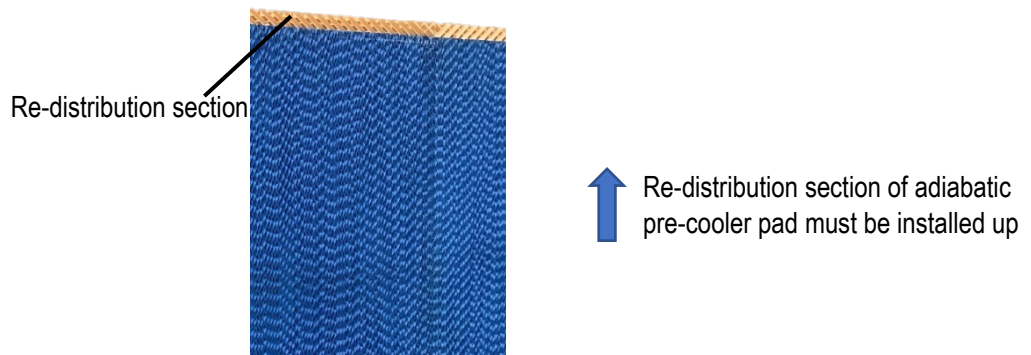

Figure 7. Re-distribution section of adiabatic pre-cooler pad

Water Distribution System

General

The water distribution system is composed of the upper water distribution channels, the lower water collection channels, and the sump.

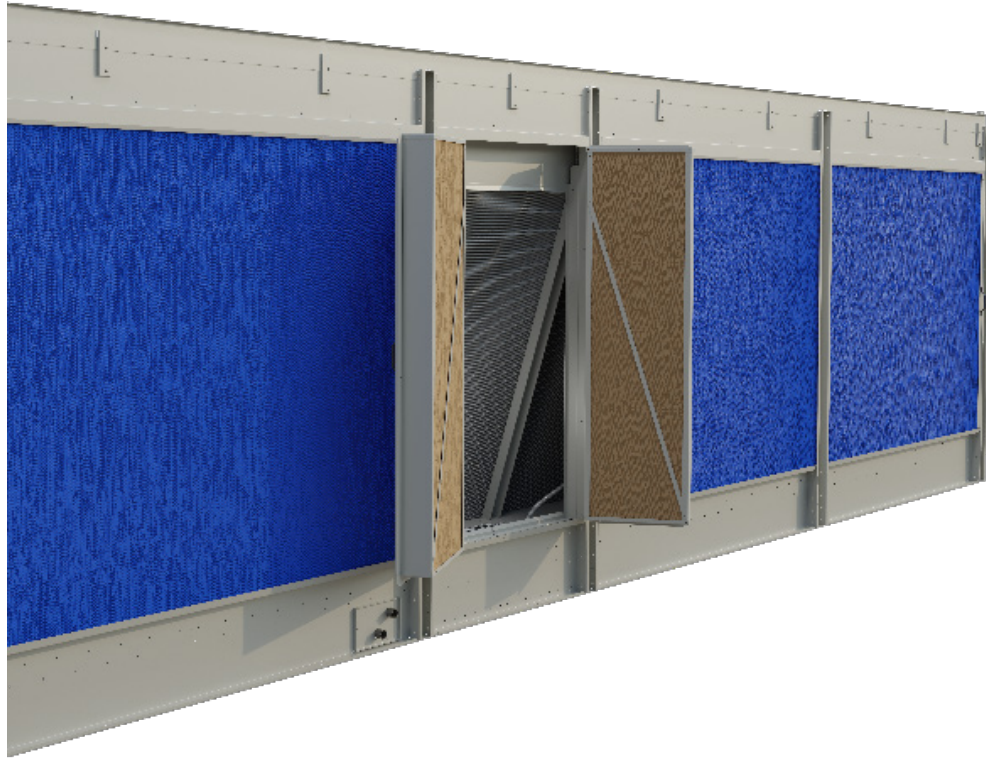

Figure 8. Sump access door

Sump Access Door (if equipped)

Where customer specified, two sump access doors are provided per unit, one per air inlet face. Refer to **Figure 8** for location of the sump access door. Always ensure the sump access door latch is engaged and secured before operating the unit, refer to **Figure 9** for details on engaging the sump access door latch. To secure the sump access door in an open position use the sump access door brackets shown in **Figure 10**. A removable pin should be inserted into the sump access door bracket to secure the sump access door in the open position.

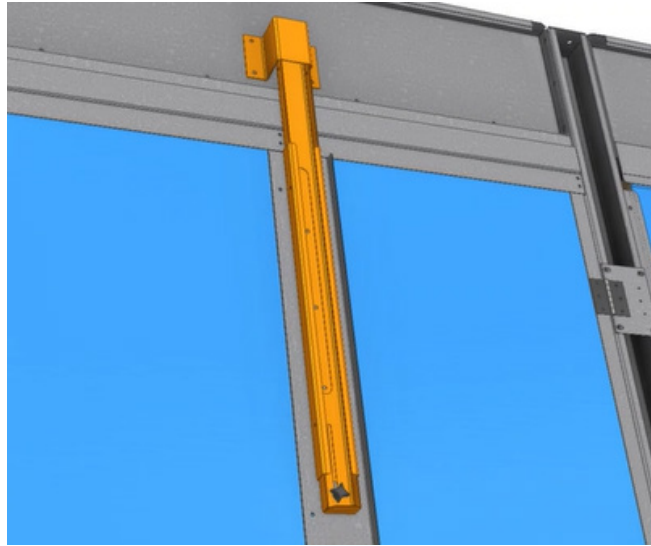
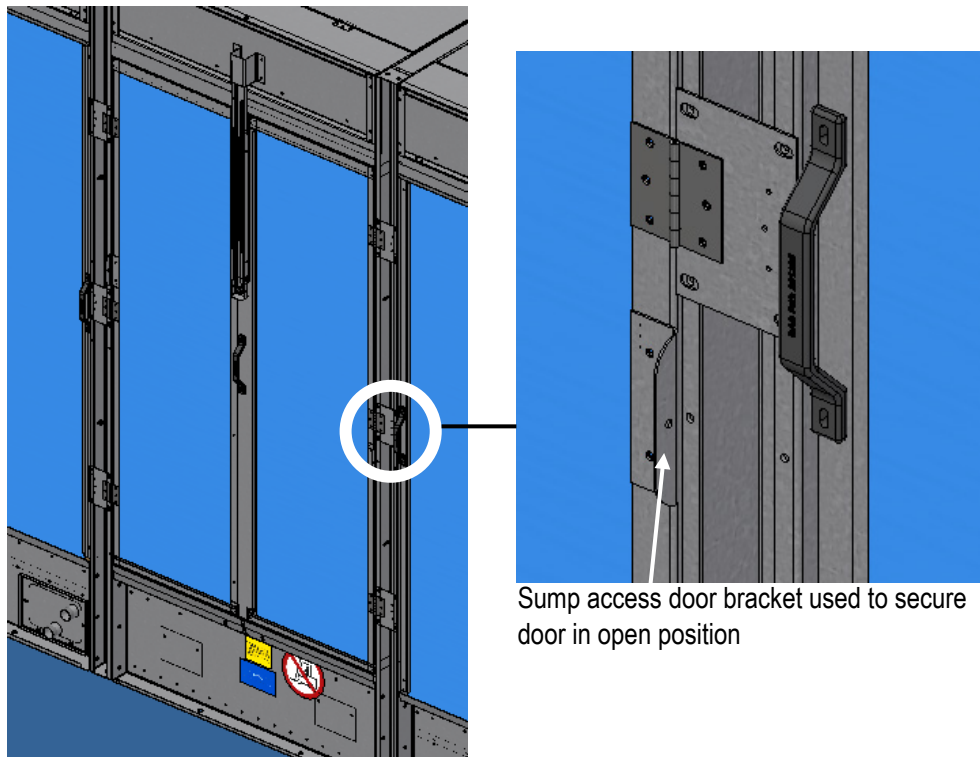

Figure 9. Sump access door latch engaged.



Sump access door bracket used to secure door in open position

Figure 10. Sump access door bracket used to secure door in open position.

Upper Water Distribution Channel

⚠ WARNING : Do not use the top horizontal surface of the unit as a walking surface or a working platform. Doing so poses a risk of falling through the surface, resulting in personal injury and/or equipment damage.

The upper water distribution channels are filled with water either by the make-up water connection or the recirculation pump. Water is then distributed over the adiabatic pre-cooler pads via a special hole pattern in the bottom of the upper water distribution channel. The upper water distribution channels require a specific water flow rate. At least quarterly and upon seasonal startup, inspect the upper water distribution channels for debris and ensure water distribution holes are not clogged. The upper water distribution channels can be inspected via the inspection covers that run the length of the unit on the air inlet faces as shown in **Figure 11**. Screws securing the inspection cover are for shipping purposes.

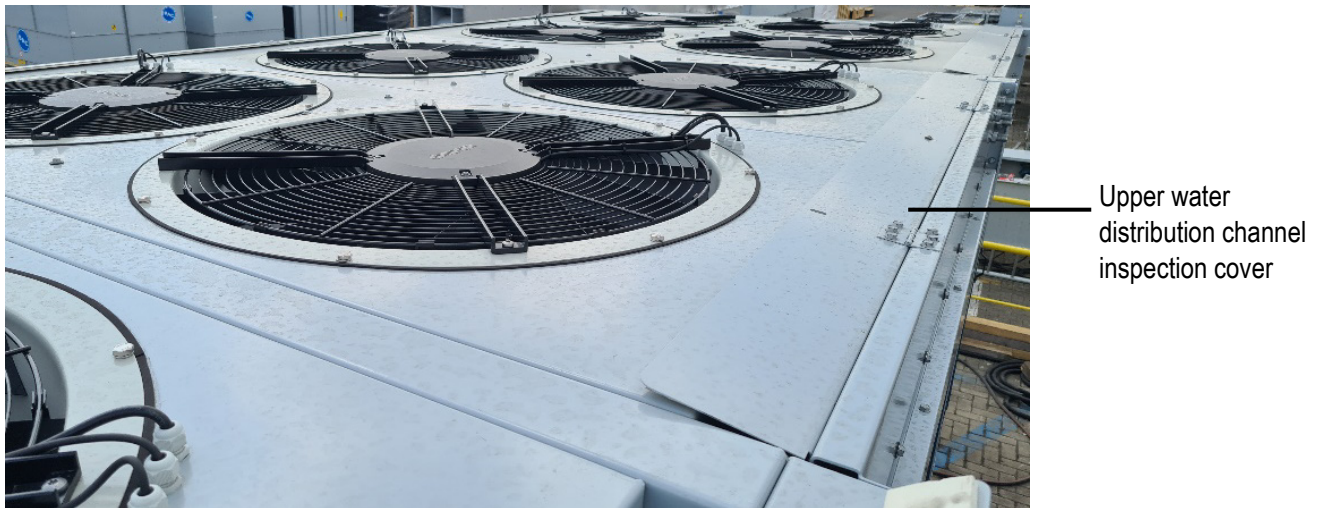

Figure 11. Upper water distribution channel inspection cover

Lower Water Collection Channel

The lower water collection channels collect water coming off the adiabatic pre-cooler pads and redirects it into the sump. At least quarterly and upon seasonal startup, inspect the lower water collection channels for debris. Removal of the adiabatic pre-cooler pads is required to inspect the lower water collection channels, refer to

Adiabatic Pre-Cooler Pad Removal on **Page 23**. Refer to **Figure 12** for location of the lower water collection channels.

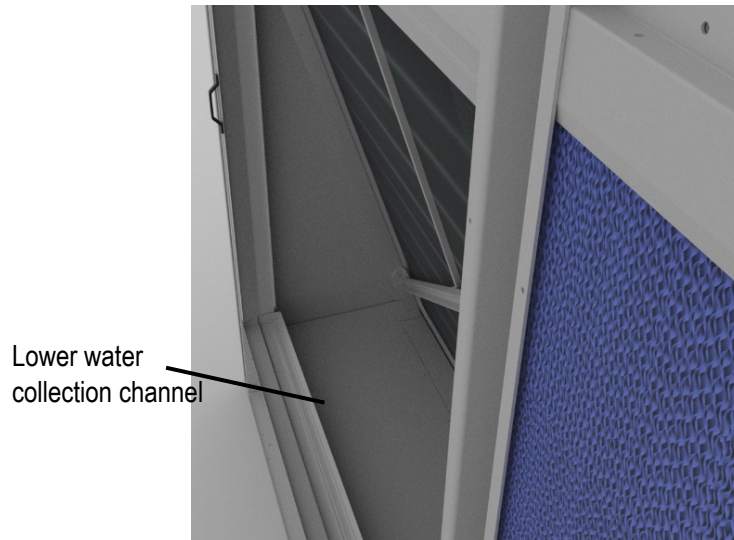

Figure 12. Lower water collection channel

Sump Strainer (if equipped)

Where customer specified, a removable stainless-steel sump strainer is supplied for each air inlet face as shown in **Figure 13**. Do not operate the unit with the sump strainers removed to prevent debris from damaging the unit or reducing water flow. The sump strainers can be accessed via the sump access doors. To remove the sump strainer, remove all wingnuts securing the assembly and lift the assembly out of the unit using the grab handle. Ensure all wingnuts are reinstalled when reinstalling the sump strainer. At least quarterly and upon seasonal startup, remove and clean the sump strainers and replace, as necessary. Clean the sump strainer by removing all surface debris and ensuring the perforations are clear.

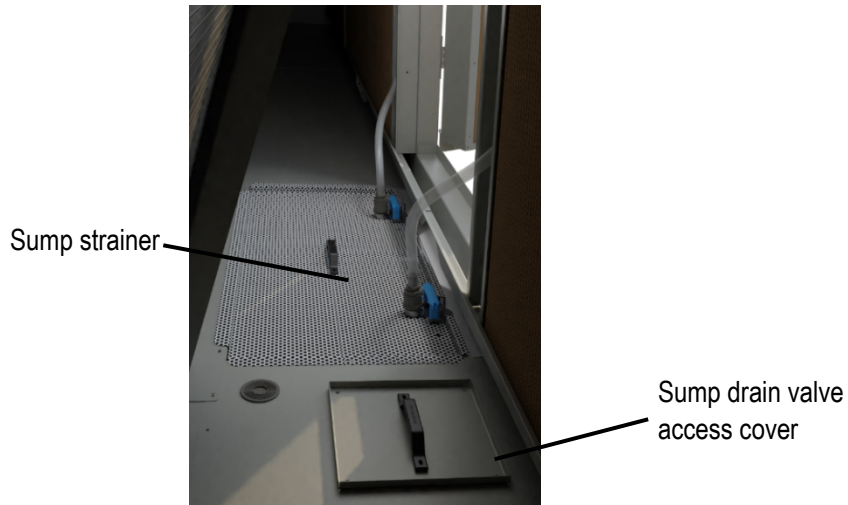

Figure 13. Sump strainer & sump drain valve access cover

Recirculation Pump

Each unit is supplied with two 1/3 HP submersible recirculation pumps as shown in **Figure 14**. Each pump recirculates water to one air inlet face. Both pumps are located on the same side of the unit and can be accessed via the sump access door. Never lift or carry the pump by the electrical cord, use the pump handle to install/remove pump. At least quarterly and upon seasonal startup, clean the pump by removing debris from the bottom strainer portion of the pump.

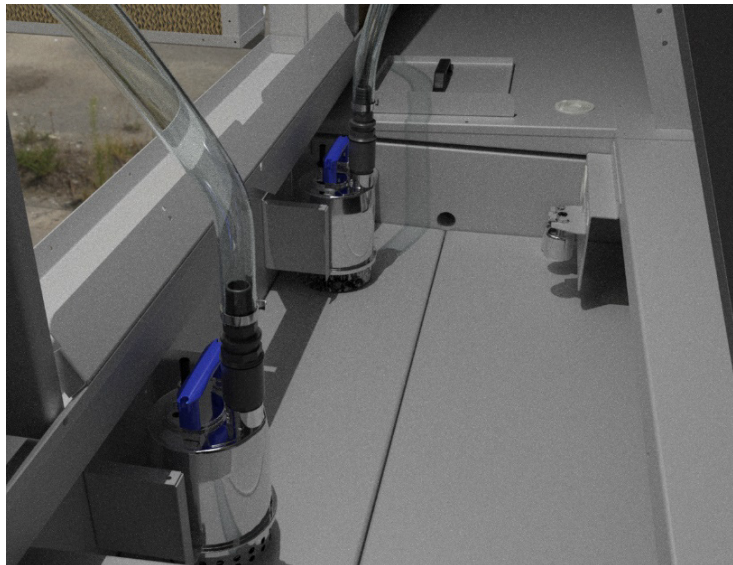

Figure 14. Submersible recirculation pumps

Sump Water Level Radar Sensor (if equipped)

Where customer specified, the unit is equipped with a radar sensor to maintain the water in the at a level that ensures sufficient water is available for a proper wetting of the adiabatic pre-cooler pads. The sensor is factory set at the correct level. Each unit is supplied with one sump water level radar sensor as shown in **Figure 15**.



Figure 15. Sump Water Level Radar Sensor

Sump Water Level Float Switches (if equipped)

Where customer specified, three industrial grade stainless steel float switches maintain the water level in the sump between a minimum and maximum level in order to ensure sufficient water is available for a proper wetting of the adiabatic pre-cooler pads. All switches are factory set at the correct level. Each unit is supplied with three sump water level float switches as shown in **Figure 16**. At least quarterly and upon seasonal startup, inspect to confirm that each float is free to move and not coated with any substance. Clean each float switch as needed. This can be done without disturbing the installation by wiping the float and stem to remove any buildup.



Figure 16. Sump water level float switches

Sump Drain Valve

The sump drain valve is normally open (fail open). The sump drain valve can be accessed from underneath the unit as shown in **Figure 17** or via the sump drain valve access cover shown in **Figure 13**. The sump drain valve access cover is secured with plastic knobs. Always ensure the plastic knobs are reinstalled after replacing the sump drain valve access cover. This device is not adjustable and does not have any service or maintenance requirements.

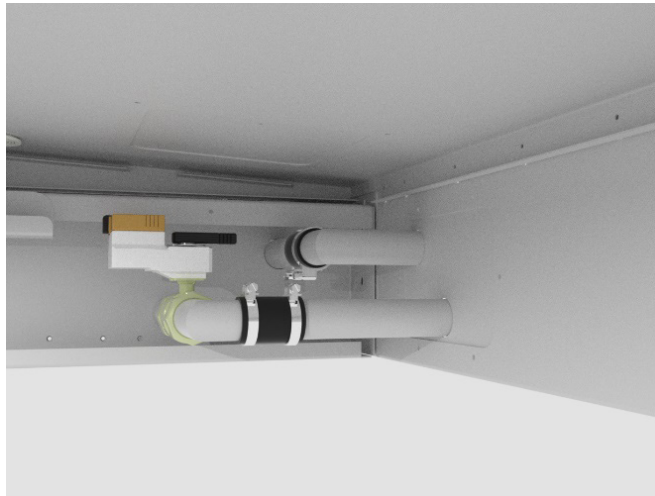

Figure 17. Sump drain valve viewed from underneath the unit

Fan and Motor

General

This unit utilizes electronically commutated (EC) axial fan and motor assemblies with integrated speed controller and guard grill. Fans must rotate without obstruction in the direction indicated by arrows on the equipment. Fans must be started up and operated at full speed for at least three hours once a month to move the bearings and allow any condensate that may have ingressed to evaporate.

Fan Types

This unit utilizes two versions of EC axial fan and motor assemblies. Fan parameters will differ between the two versions. Fans can be identified by their physical appearance as shown in **Figure 18 & Figure 19**. Alternatively, a BAC part number label is affixed to each fan indicating the BAC part number, as shown in **Figure 18 & Figure 19**.



BAC Part
Number Label

Figure 18. BAC Part Number 251299 EC Fan and Motor Assembly



BAC Part
Number Label

Figure 19. BAC Part Number 251317 EC Fan and Motor Assembly

Minimum Fan Speed

If the unit control type is customer input the fans will stop when the input signal is within the signal range listed in **Table 4**.

Signal Type	0 RPM Fan Speed Signal Range
4-20mA	4mA – 4.8mA
0-10V	0V – 0.05V
10-0V	10V – 9.95V
BMS 0-100%	0% - 5%

Table 4. Input Signal Zero Fan Speed Signal Range

⚠ DANGER: This unit contains rotating equipment that can cause severe personal injury or death upon contact. Never remove or step on a fan guard grill, subject the fan guard grill to load, or place any objects on the fan guard grill. Employ safeguards (including the use of protective enclosures where necessary) to prevent public access to equipment.

⚠ WARNING: Risk of electric shock. Live terminals and connections even with device switched off. Wait five minutes after disconnecting the voltage at all poles before opening the fan and motor assembly.

⚠ WARNING: Transporting the fan. Injuries from tipping or slipping. Wear safety shoes and cut-resistant safety gloves. The fan is only to be transported in its original packaging. The fan is to be transported lying flat, i.e., the motor axis must be vertical. Secure the fan(s) e.g., with a lashing strip to stop anything from slipping or tipping.

⚠ CAUTION: The surface of the fan motor electronics housing can get very hot and pose the risk of burns. Wear appropriate PPE to ensure sufficient protection against accidental contact with the fan motor housing.

BAC Part Number 251299, Fan and Motor Removal & Installation

The following procedure is for field removal and installation of BAC part number 251299 EC fan and motor assembly. Refer to section **Fan Types** on **Page 33** for more information on how to identify fan type and part number.

1. Turn off power to the unit.
 - a. Turn power off at the main breaker and follow lock out/tag out procedures.
 - b. Before disconnecting any power wires, use a multi-meter to verify that there is no voltage.

2. Remove the fan cover plate by removing the four fasteners as shown in **Figure 20**.

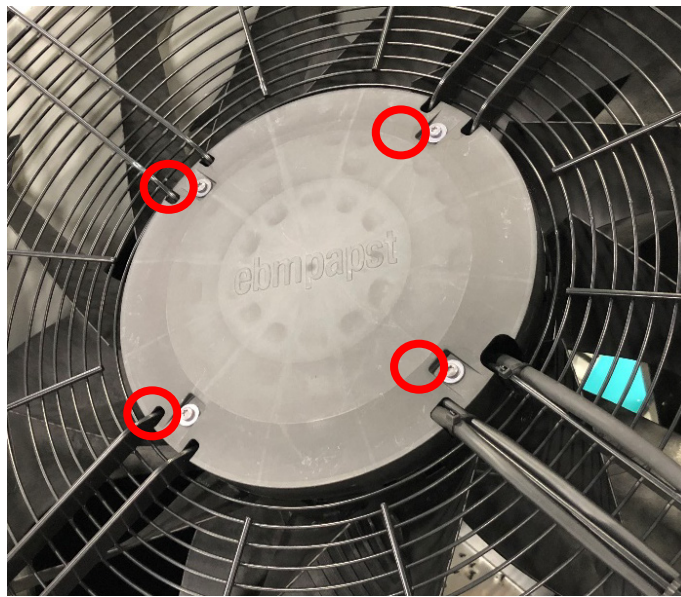

Figure 20. Fan Cover Plate

- Remove the terminal box cover by removing the four fasteners as shown in **Figure 21**.

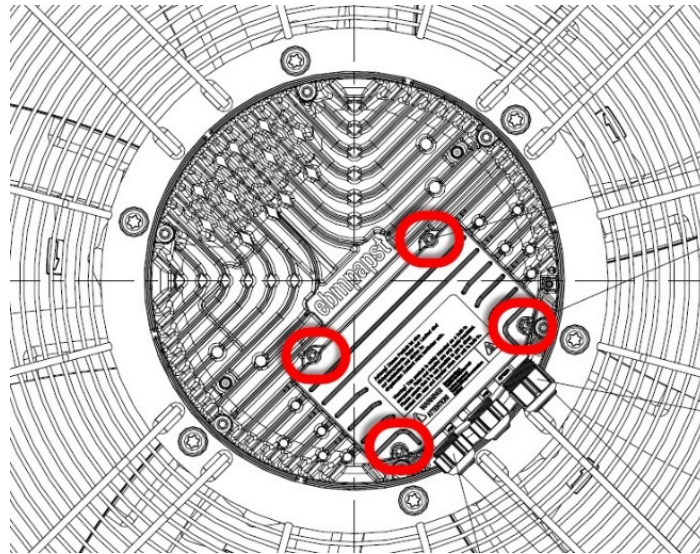

Figure 21. Terminal Box Cover

- Remove caps from the cable glands. Label and remove wiring from terminal blocks shown in **Figure 22**. Carefully tag these wires properly to ensure that they are connected at the same location on the new fan. These wires carry polarity sensitive signals.

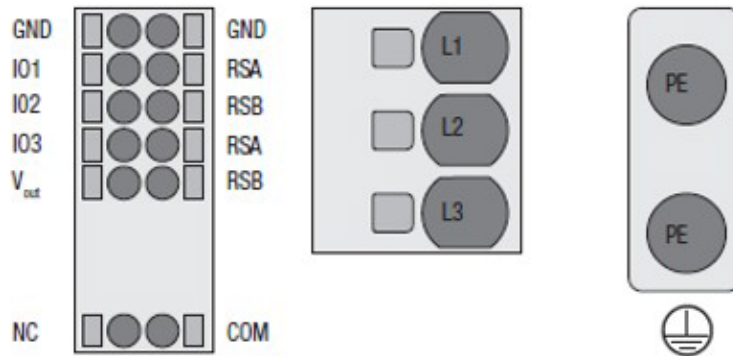

Figure 22. Terminal Block Diagram

- Remove wires from terminal box and cable glands. Cut zip cable ties securing wiring to fan assembly.

6. Remove the (8) 9/16" bolts securing the fan and motor assembly to the fan deck as shown in **Figure 23**.



Figure 23. Fan Deck Fasteners

7. Lift the fan and motor assembly up and out of the fan deck. If a lifting device is utilized, lift the assembly via the support channels as shown in **Figure 24**. Be sure to rig the assembly to ensure no damage to the guard grill will occur during lift.



Figure 24. Fan and Motor Assembly Lift

The optional fan removal system includes a moveable davit assembly as shown **Figure 32**. To the remove the fan

- a. Lower davit arm into davit support.
- b. Attach fan to the davit. Rotate the fan as necessary when removing the fan.
- c. Follow fan removal steps as shown above.
- d. Relocate davit arm as necessary.



Figure 25: Fan Removal System

8. Once the fan is removed, clean the surface where the fan meets the top of the unit and apply new foam tape.
9. Lift the new fan and motor assembly into position ensuring mounting holes are aligned and that there are no gaps around the fan housing.
10. Reinstall the (8) 9/16" bolts to secure the fan and motor assembly to the fan deck as shown in **Figure 23**.
11. Remove the fan cover plate and terminal box cover shown in **Figure 20** and **Figure 21** respectively. Remove caps from the cable glands.

12. Wire terminal blocks shown in **Figure 22** following the wire labels created in **Step 4**. Refer to **Table 5** for more information on connection designations. Only strip the cable as far as necessary, ensuring that the cable glands are sealed and there is no strain on the connections. Recommended stripped lengths (inside terminal box) are shown in **Figure 26**, (1) supply line (2) control and relay line. After terminating the wire, pull-test the wire to ensure proper installation.

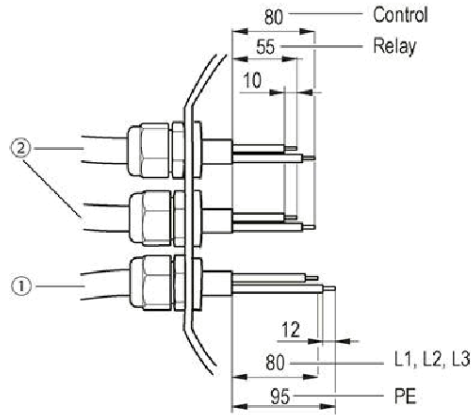

Figure 26. Recommended Stripped Lengths (Inside Terminal Box) (1) Supply Line (2) Control and Relay Line

Conn.	Designation	Function/assignment
CONN1	L1, L2, L3	Power supply, phase, see nameplate for voltage range
PE	PE	Protective earth
CON2	RSA	RS485 interface for MODBUS, RSA; SELV
CON2	RSB	RS485 interface for MODBUS, RSB; SELV
CON2	GND	Reference ground for control interface, SELV
CON2	IO1	Function parameterizable Factory setting: Digital input - high active, function: Disable input, SELV - inactive: Pin open or applied voltage < 1.5 VDC - active: applied voltage 3.5-50 VDC Reset function: Triggering of error reset on change of state from "enabled" to "disabled"
CON2	IO2	Function parameterizable Factory setting: Analog input 0-10 V / PWM, Ri=100 kΩ, function: Set value Characteristic curve parameterizable, SELV
CON2	IO3	Function parameterizable Factory setting: Analog output 0-10 V, max. 5 mA, function: Fan modulation level Characteristic curve parameterizable, SELV
CON2	Vout	Voltage output 3.3-24 VDC ±5%, Pmax=800 mW, voltage parameterizable Factory setting: 10 VDC short-circuit-proof, supply for external devices, SELV alternatively: 15-50 VDC input for parameterization via MODBUS without line voltage
CON2	COM	Status relay, floating status contact, common connection, contact rating 250 VAC / 2 A (AC1) / min. 10 mA, reinforced insulation on supply side and on control interface side
CON2	NC	Status relay, floating status contact, break for failure
	LED	green: status = good, ready for operation orange: status = warning red: status = failure
	P1-IN	Input characteristic curve
	P3-OUT	Output characteristic curve

Table 5. Legend for Internal Motor Terminal Strip

- Using zip cable ties secure cables to the fan and motor support channels. Ensure the cable is routed in a U-shape as shown in **Figure 27**.

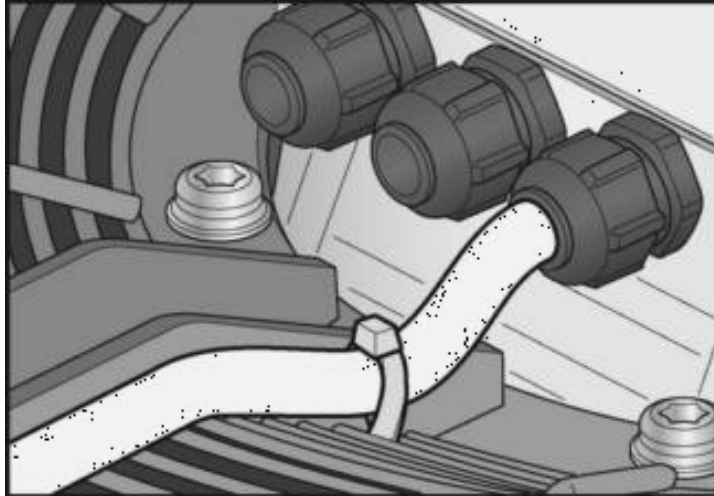

Figure 27. Fan and Motor Assembly Cable Routing

14. Reinstall cable gland caps with a tightening torque of 4 ± 0.6 Nm. Make sure all cable glands not in use are fitted with dummy plugs. Cable diameter minimum 4 mm, maximum 10 mm. Proper installation of cable gland caps is critical to maintain the weatherproof rating of the unit. If the above procedure is not followed, damage due to water ingress will occur.
15. Inspect the terminal box cover gasket and reinstall the terminal box cover with a tightening torque of 1.5 ± 0.2 Nm as shown in **Figure 21**. Proper installation of the terminal box cover is critical to maintain the weatherproof rating of the unit. If the above procedure is not followed, damage due to water ingress will occur.
16. Reinstall the fan cover plate with a tightening torque of 3 ± 0.3 Nm as shown in **Figure 20**.
17. Follow **Readdress New Fan** on **Page 99**

BAC Part Number 251317 EC Fan and Motor Assembly Removal & Installation

The following procedure is for field removal and installation of BAC part number 251317 EC fan and motor assembly. Refer to **Fan Types** on **Page 33** for more information on how to identify fan type and part number.

2. Turn off power to the unit.
 - a. Turn power off at the main breaker and follow lock out/tag out procedures.
 - b. Before disconnecting any power wires, use a multi-meter to verify that there is no voltage.

3. Remove the terminal cover by removing the four M4x8 mm fasteners as shown in **Figure 28**.

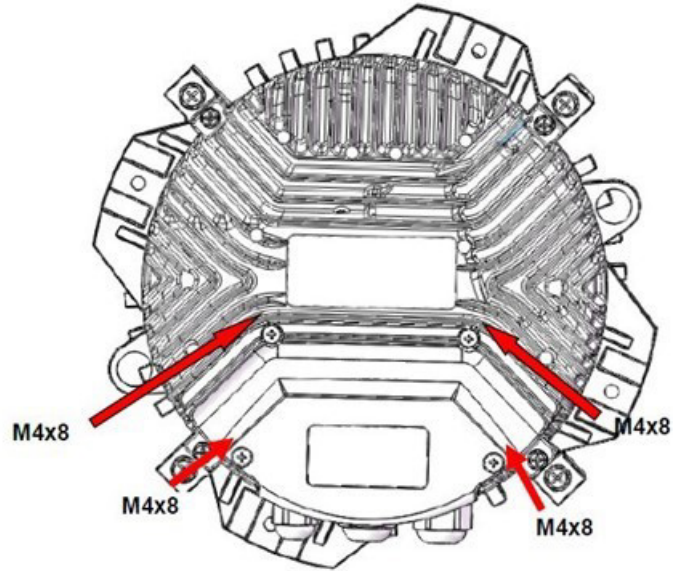

Figure 28. Terminal Cover

4. Remove caps from the cable glands. Label and remove wiring from terminal blocks shown in **Figure 29**. Carefully tag these wires properly to ensure that they are connected at the same location on the new fan motor. These wires carry polarity-sensitive signals.

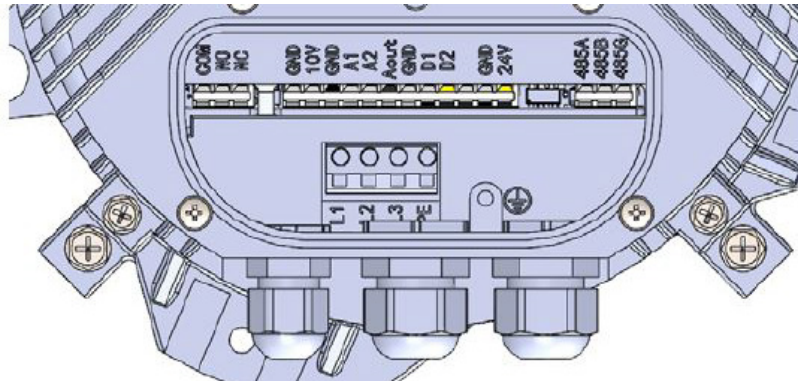

Figure 29. Terminal Block Diagram

5. Remove the wires from the terminal box and cable glands. Cut the zip cable ties securing the wiring to the fan assembly.

- Remove the (8) 9/16" bolts securing the fan and motor assembly to the fan deck as shown in **Figure 30**.



Figure 30. Fan Deck Fasteners

- Lift the fan and motor assembly up and out of the fan deck. If a lifting device is utilized, lift the assembly via the support channels as shown in **Figure 31**. Be sure to rig the assembly to ensure no damage to the guard grill will occur during lift.

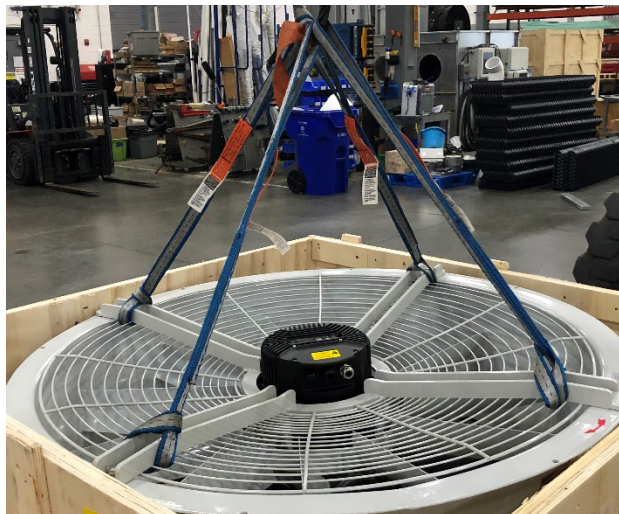

Figure 31. Fan and Motor Assembly Lift

The optional fan removal system includes a moveable davit assembly as shown **Figure 32**. To the remove the fan

- a. Lower davit arm into davit support.
- b. Attach fan to the davit. Rotate the fan as necessary when removing the fan.
- c. Follow fan removal steps as shown above.
- d. Relocate davit arm as necessary.



Figure 32: Fan Removal System

8. Once the fan is removed, clean the surface where the fan meets the top of the unit and apply new foam tape.
9. Lift the new fan and motor assembly into position ensuring that the mounting holes are aligned and that there are no gaps around the fan housing.
10. Reinstall the (8) 9/16" bolts to secure the fan and motor assembly to the fan deck as shown in **Figure 30**.
11. Remove the terminal cover shown in **Figure 28**. Remove caps from the cable glands.
12. Wire the terminal blocks shown in **Figure 33**, following the wire labels created in **Step 4**. Refer to **Table 6** for more information on connection designations. After terminating the wire, pull-test the wire to ensure proper installation.
 - a. Use the middle cable gland for the mains supply cable.
 - b. Only strip the cable as far as necessary.

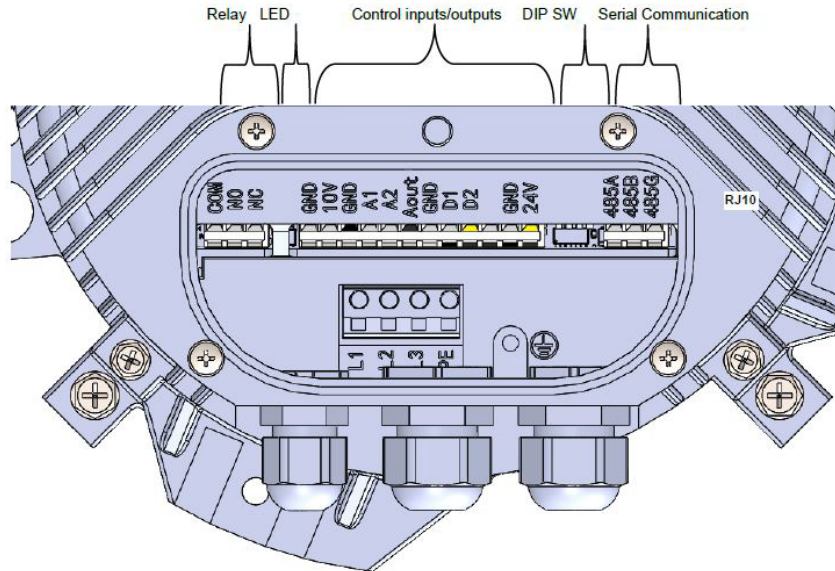

Figure 33. Terminal Strip Layout

Name	Function
L1	Power input phase 1
L2	Power input phase 2
L3	Power input phase 3
PE	Protective earth
PE Screw	Protective earth on housing
COM	Output relay common contact
NO	Output relay N.O. contact
NC	Output relay N.C. contact
GND1	Signal ground
+10V	+10V VDC auxiliary supply max 10mA
GND1	Signal ground
A1	Analog input 1
A2	Analog input 2
AOut	Analog output
D1	Digital input 1
D2	Digital input 2
GND1	Signal ground
+24V	+24V VDC short-circuit current, 50 mA max
485A	RS 485 data +
485B	RS 485 data -
GND1	RS 485 ground

Table 6. Legend for Internal Motor Terminal Strip

13. Ensure the 4 dip switches S1 to S4 shown in **Figure 34** have the correct function as listed below.
- Fan communication wires are daisy chained across all fans. The last fan in the communication daisy chain, fan number 2 shown in **Figure 109** on **Page 99** must be set to Terminated as listed in **Table 7**.
 - All other fans must be set to NO Termination NO Biasing (default) as listed in **Table 7**.

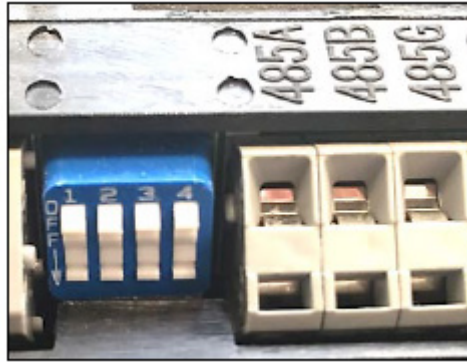

Figure 34. RS485 Termination/Biasing DIP Switches

S1	S2	S3	S4	Function
OFF	OFF	OFF	OFF	NO Termination NO Biasing (default)
ON	ON	OFF	OFF	Terminated
OFF	ON	ON	ON	Terminated and Biased
OFF	OFF	ON	ON	Biased

Table 7. RS485 Termination/Biasing DIP Switch Functions

14. Using zip cable ties secure cables to the fan and motor support channels. Ensure the cable is routed in a U-shape as shown in **Figure 35**.

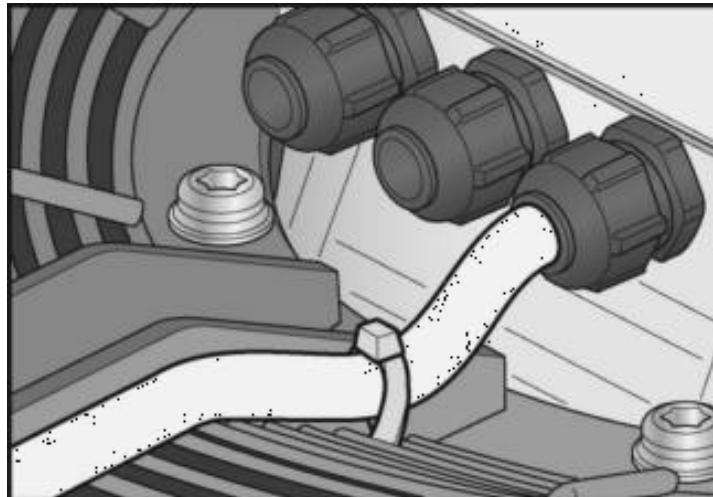

Figure 35. Fan and Motor Assembly Cable Routing

15. Reinstall cable gland caps with the tightening torque shown in **Figure 36**. Make sure all cable glands not in use are fitted with dummy plugs. Ensure that the cable glands are sealed and there is no strain on the connections. Proper installation of cable gland caps is critical to maintain weatherproof rating of the unit. If the above procedure is not followed, damage due to water ingress will occur.

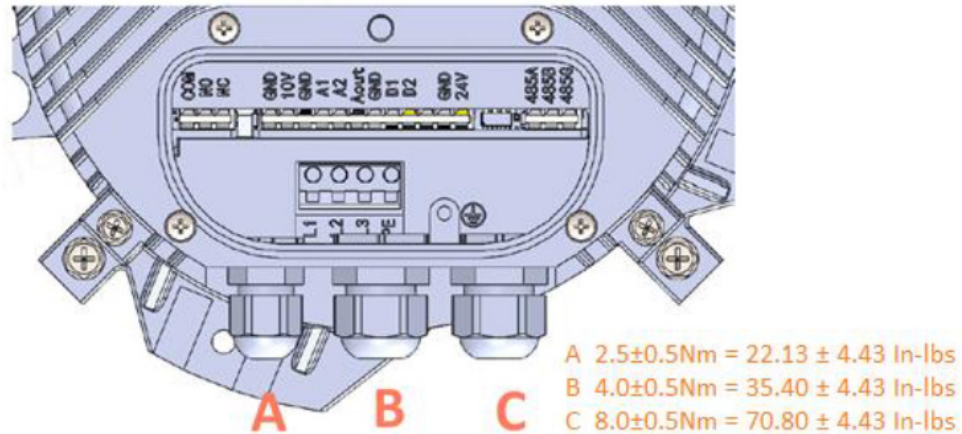

Figure 36. Tightening Torques for Cable Gland Caps

16. Inspect the terminal cover sealing gasket shown in **Figure 37** for damage and replace if damaged. Reinstall the terminal cover taking care that the sealing gasket is in the correct position. Use a torque wrench to tighten the screws with a torque of 1.6 ~2.4 Nm. Proper installation of the terminal box cover is critical to maintain weatherproof rating of the unit. If the above procedure is not followed, damage due to water ingress will occur.



Figure 37. Terminal Cover Sealing Gasket

17. Follow section **Readdress New Fan** on **Page 99**.

Finned Coil Heat Exchanger

Refer to the unit submittal package for the finned coil heat exchangers maximum allowable working pressure (MAWP). Finned coil heat exchanger types will vary depending on the model and design. Proper finned coil heat exchanger maintenance should be followed regardless of coil type. The finned coil heat exchanger should be inspected quarterly; it is susceptible to corrosion and entrapment of airborne particulates (coil fouling). The speed of coil fouling can be reduced, and the service lifetime of the coil can be extended, if the adiabatic pre-cooler pads are always kept in place to act as air filter.

- To keep the coils in optimum condition, ensure that Self-Clean Cycles are enabled. Refer to section
-
- **Maintenance Menu on Page 73** for more details.
- To inspect the coil, the adiabatic pre-cooler pads must be removed, refer to section Adiabatic Pre-Cooler Pad Removal on **Page 23**.
- Inspect the coil surface. Any corrosion, damage, or obstructions must be corrected.
- To manually clean the coils, use a standard garden hose. Never use a brush or pressure washer. First, rinse the outside surface dust and dirt into the water collection gutters and the sump. Continue to rinse until the water easily flows to the inside of the unit and into the sump. Do not use harsh chemicals or extreme water pressure.
- Additional cleaning steps that can be used to dislodge clogged coils include high pressure air, vacuum/Shop-Vac®, or a mild detergent such as Nu Calgon Cal-Green MX coil cleaner (use per manufacturer's instructions).
- The sump and water collection gutters should be cleaned immediately after cleaning the coil to avoid clogging the pump and drain valves.
- Coated coils: Inspect coil coating. To touch up blemished areas, use a Red Epoxy Repair Kit.
- Re-install the adiabatic pre-cooler pads per section **Adiabatic Pre-Cooler Pad Removal on Page 23**.

Control Panel

Thermostat Settings

The control panel is equipped with a heater fan and a ventilation fan for maintaining temperatures required for the proper function of electronics. The heater fan thermostat dial should be set to 55°F (13°C), use the thermostat dial shown in **Figure 38**. The ventilation fan thermostat dial should be set to 90°F (32°C), use the thermostat dial shown in **Figure 38**.

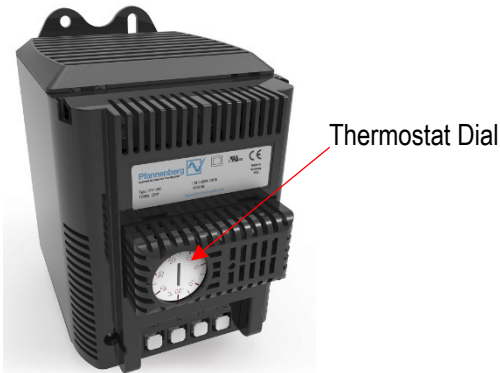

Figure 38. Control Panel Heater Thermostat Dial

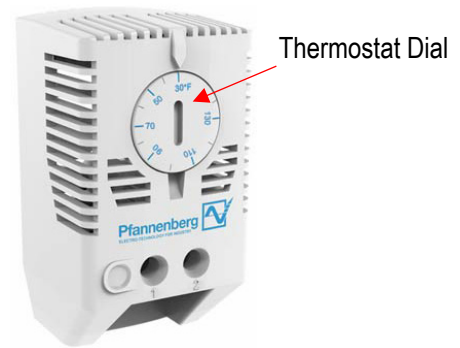

Figure 39. Control Panel Ventilation Fan Thermostat Dial

Programmable Logic Controller (PLC)

Only the manufacturer may repair the PLC device. If a repair should be necessary, contact your local BAC Representative.

Control Panel Ventilation

The control panel is equipped with intake and exhaust filters. Only original filter mats must be used for the operation of filter fans and outlet filters. Minimum filter material replacement intervals are shown in **Table 8**

Ambient Conditions	Fluted Filter
Coarse particles	min. 1 time per year
Dust-laden / spray mist	min. 3 times per year
Very high oil content	min. 2 times a month
Without corresponding loads	min. 1 time per year

Table 8: Minimum Filter Material Replacement Intervals

8. Control Logic

The controller controls the fan speed based on the actual fluid outlet temperature and the standard or free cooling set point, ensuring a minimum electrical consumption and noise level. The PLC will operate as described in **Figure 40**. The process fluid temperature set point and the adiabatic switchpoint are adjustable via the Setpoint menu. The PLC continuously measures the fluid output temperature via a temperature sensor installed in the fluid out pipe, and the ambient temperature via a temperature sensor that is factory installed on the unit. The PLC is pre-programmed and ready for operation. However, depending on the size of the installation, you may need to adjust the pre-programmed parameters during start-up.



NOTE: Changing the controller's parameters may result in an undesired operation of the unit, such as a hunting phenomenon, premature activation of pre-cooling (and increased water consumption) or delayed pre-cooling activation (fluid outlet temperatures exceeding the design temperature). For further questions, contact BAC.

Sequence of Operation Diagram

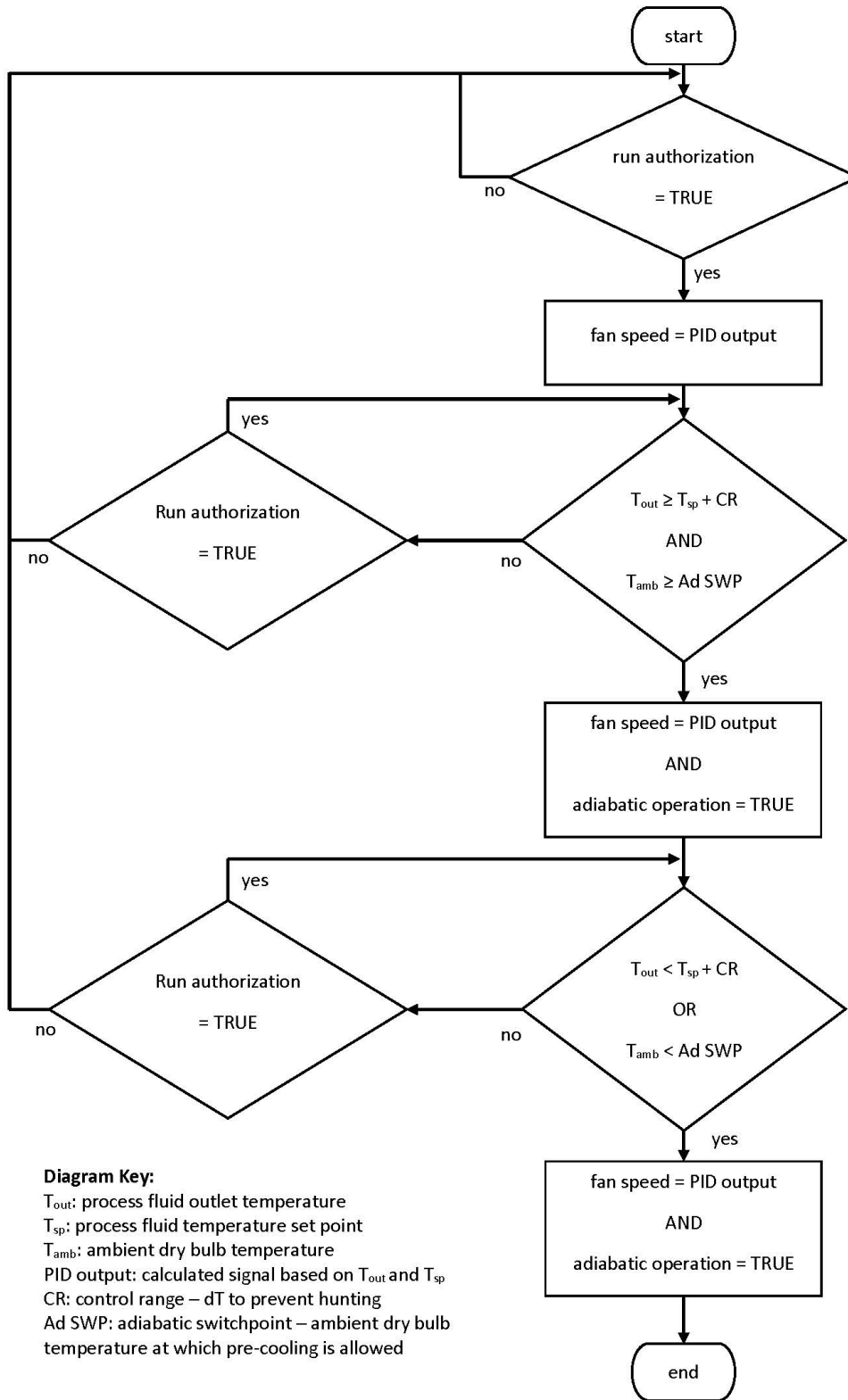

Figure 40. Sequence of Operation Diagram

9. User Interface

Home Menu

The screen or Human Machine Interface (HMI) home menu is shown in **Figure 41**. The home menu displays the leaving fluid temperature or customer input command, leaving fluid temperature setpoint or customer input command, control mode, fan command, and system messages. In addition to all unit and fan alarms, the system messages box can show the messages shown in **Table 9**.

Pressing the “run authorization” button in the upper left-hand corner will toggle the run authorization, turning the unit on or off. Pressing the icons near the bottom of the screen will navigate to their respective menus below.

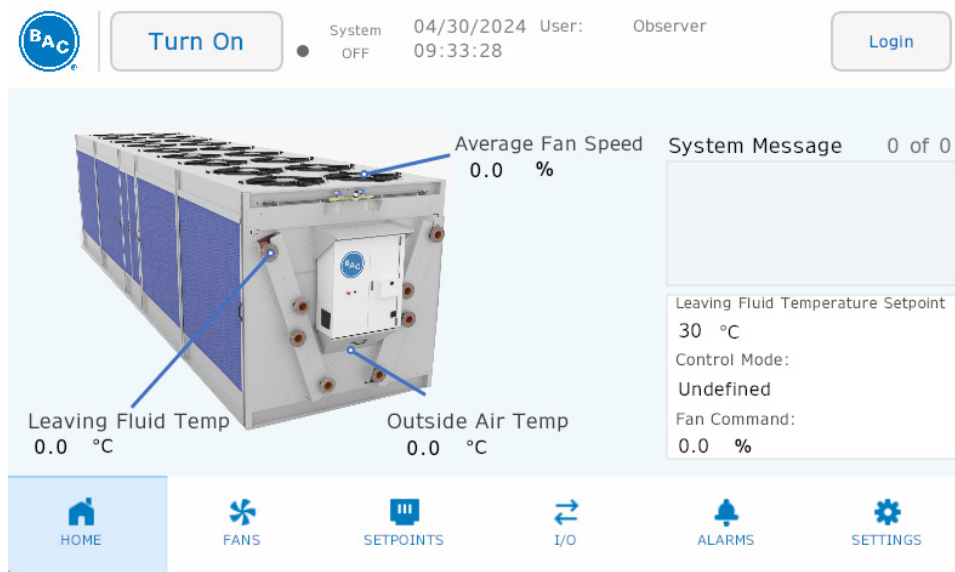

Figure 41. Home Menu

Message Text	Description
Cycle of Concentration Drain	After a set value is reached, the sump is drained to flush out a build-up of excess minerals.
Pump X Anti-Recycle (AR) Timer Active	A timer to prevent excessive on/off cycling of the adiabatic pre-cooler circulation pumps
Water Usage Disabled	Indicates if the unit is restricted from entering adiabatic operation
Night Quiet Mode Active	Indicates if night quiet mode is active
Night Dry Mode Active	Indicates if night dry mode is active
Schedule Dry Mode Active	Indicates if scheduled dry mode is active
Emergency Mode Active	Indicates if the emergency mode is active. During this mode, the fan speed is no longer controlled by the PLC but rather fixed at a predefined level.

Table 9. System Messages

Access Levels

Multiple access levels are present within the software. By pressing the “Logout” button in the upper right corner of the screen as shown in **Figure 41** a user can enter the login screen as shown in **Figure 42**. A password is required to access each level other than user. Access level usernames and passwords are shown in **Table 10**. Pressing the cancel button will return the user to the home menu.

Figure 42. Login Screen

Access Level	Username	Password
User	n/a	n/a
Technician	Technician	4734

Table 10. Access Levels and Passwords

Changing Password

To change the password the user must enter the correct corresponding Username and Password for the Access Level for a new password to be used. Furthermore, the New Password and Confirm Passwords must match.

Pressing the Cancel button shall return the user to the Login Screen.

Figure 43. Login Screen

Overview Menu

The HMI is divided into 4 sections as shown in **Figure 44**.

1. HMI header (top)
2. Main menu (bottom),
3. Sub menu (left)
4. Information section (right)

Menu and sub menu names are shown in **Table 11**.

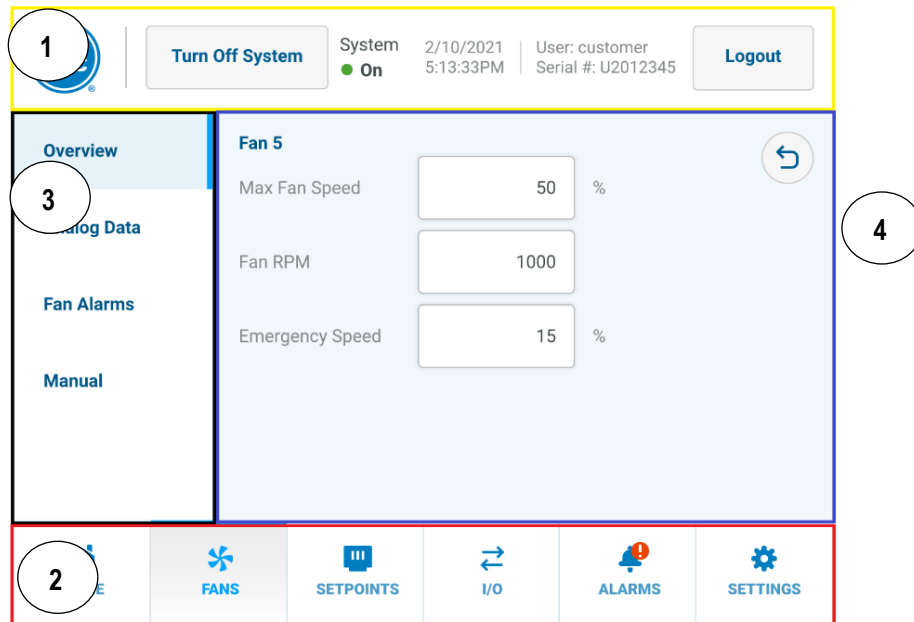

Figure 44. Typical HMI Screen Layout

Main Menu	Sub Menus
Home	
Fans	Overview, Analog Data, Fan Alarms, Manual
Setpoints	Leaving Fluid Control, Basin Water Quality, Load Limiting, Maintenance, Technician
Input/Output (I/O)	Temperatures, Make Up, Pumps, Basin Water Level, Starts and Hours, Manual
Alarms	
Settings	Setup, Software Version, Technician

Table 11. Menu and Sub Menu Names

When selecting a menu option that requires data entry, a screen will appear as shown in **Figure 45**. Pressing the “OK” button will modify the writable menu option with the value at the top. Pressing the “Cancel” button returns the user to the previous menu. Pressing the backspace key will delete the one’s place number.

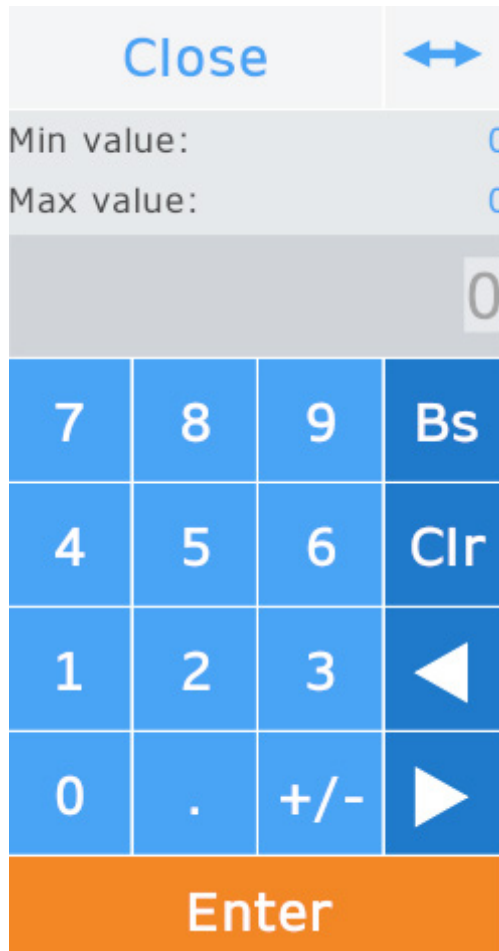

Figure 45. Data Entry Menu

Fan Menu

Figure 46 shows the fan menu. The color of the dot in each fan icon reflects that fan's status: Good (green), Alarm (red), Offline (gray), Manual (orange). Fan X's status will show as "Good" when there are no active fan alarms. Fan X's status will show as "Alarm" when any fan alarm is active. Fan X's status will show as Offline when there has not been a response from Fan X in 150 milliseconds. Fan X's status will show as "Manual" when the fan has been placed in manual mode.

Pressing on an individual fan takes the user to that fan's specific menu. Pressing on the unit diagram on the left displays the All Fans menu as shown in **Figure 47**. While in the All Fans menu all writable settings will affect all available fans and all readable parameters will be the average reading from of all available fans.

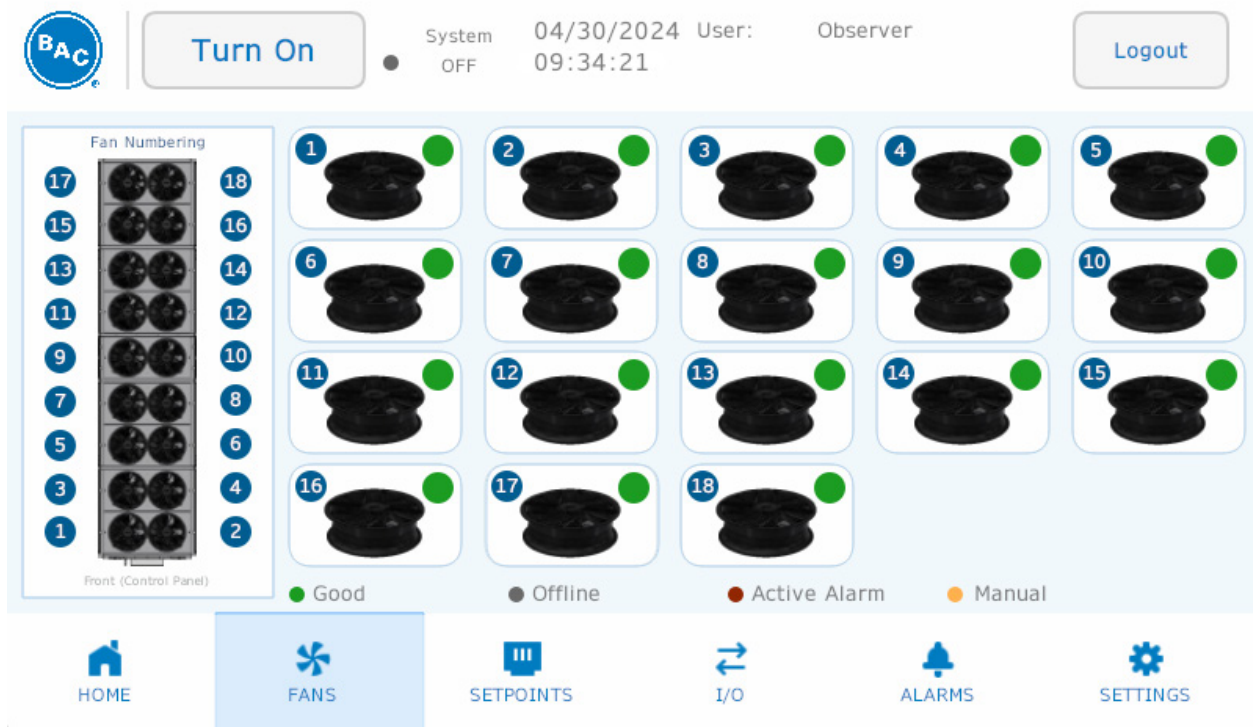

Figure 46. Fan Menu

All Fans Menu

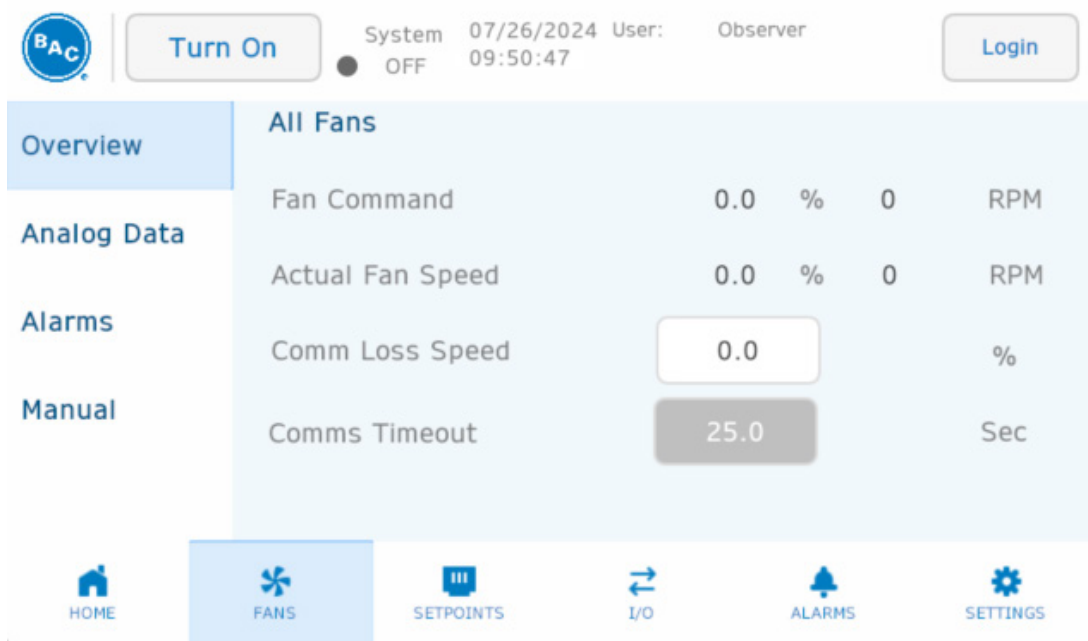

Figure 47. All Fans Menu, Overview

Parameter	Description
Fan Command	Read only
Actual Fan Speed	Read only
Comm Loss Speed	Speed at which all fans will run in case of loss of communication
Comms Timeout	Read only - Length of time after communication is lost the fans will wait before running at comms loss speed

Table 12. All Fans Menu, Overview Parameters

All Fans Analog Menu

The Analog Data (shown in **Figure 48**) displays fan data averaged across all available fans.

The screenshot shows the 'All Fans' menu with the 'Analog Data' tab selected. The interface includes a top navigation bar with a 'Turn On' button, system status (OFF), date (04/30/2024), time (09:35:24), user (Observer), and a 'Logout' button. A left sidebar contains 'Overview', 'Analog Data', 'Alarms', and 'Manual'. The main content area displays the following data:

Parameter	Value
Actual Speed	0.0 Rpm
Current Power	0.0 W
DC Link Voltage	0.0 V

At the bottom, a navigation bar includes icons for HOME, FANS, SETPOINTS, I/O, ALARMS, and SETTINGS.

Figure 48. All Fans Menu, Analog Data

All Fans Alarms Menu

Fan Alarms (shown in **Figure 49**) displays fan alarms that have occurred. When an alarm is activated, the row will be highlighted in red.

The screenshot shows the 'All Fans - Alarms' menu. The interface is similar to Figure 48, but the 'Alarms' tab is selected. The main content area displays a table with the following columns: Active Date, Active Time, and Alarm. The table is currently empty.

Active Date	Active Time	Alarm

The bottom navigation bar is the same as in Figure 48.

Figure 49. All Fans Menu, Fan Alarms

All Fans Manual Menu

The Manual menu shown in **Figure 48** only visible with Technician access level. Refer to **Table 10** Table 10. Access Levels and Passwords on **Page 53**. Setting the All Fans Manual Mode to Enable transitions the control state to Manual. The Manual menu allows a user to override the fan speed, fan rotation direction, and start, stop, or reset all fans.

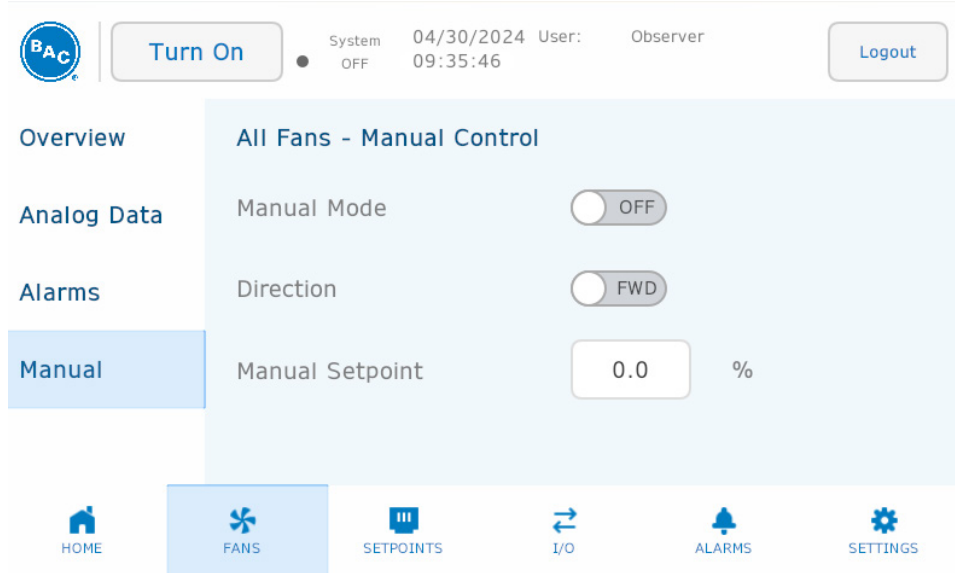

Figure 50: All Fans Menu, Manual

Fan X Overview

Pressing on Fan X in the Fan Overview menu shown in **Figure 46** brings the user to the Fan X Overview tab shown in **Figure 51**. Analog Data menu is reflected in **Figure 52**. Fan Alarms menu is reflected in **Figure 53**; however, information displayed on these menus is per fan.

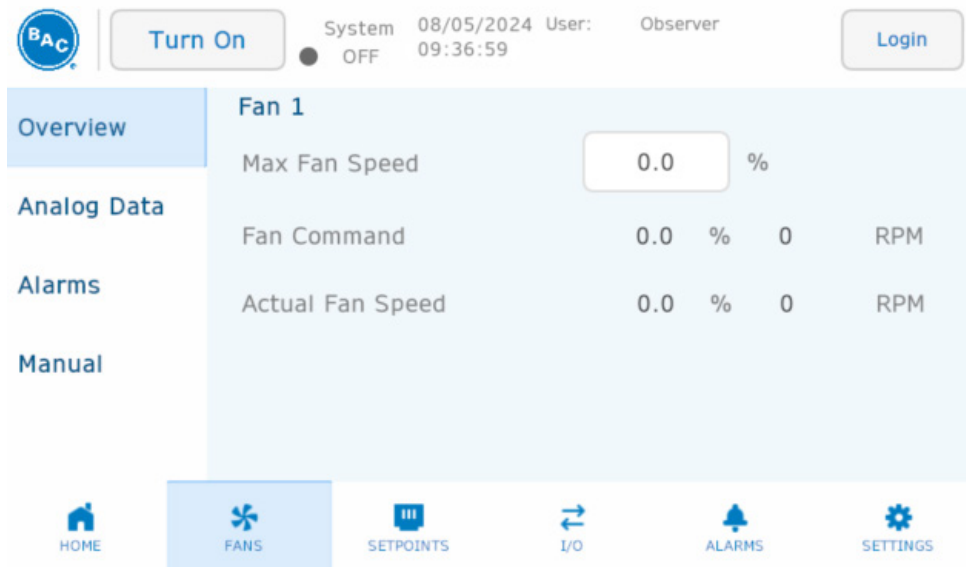

Figure 51. Fan X Menu, Overview

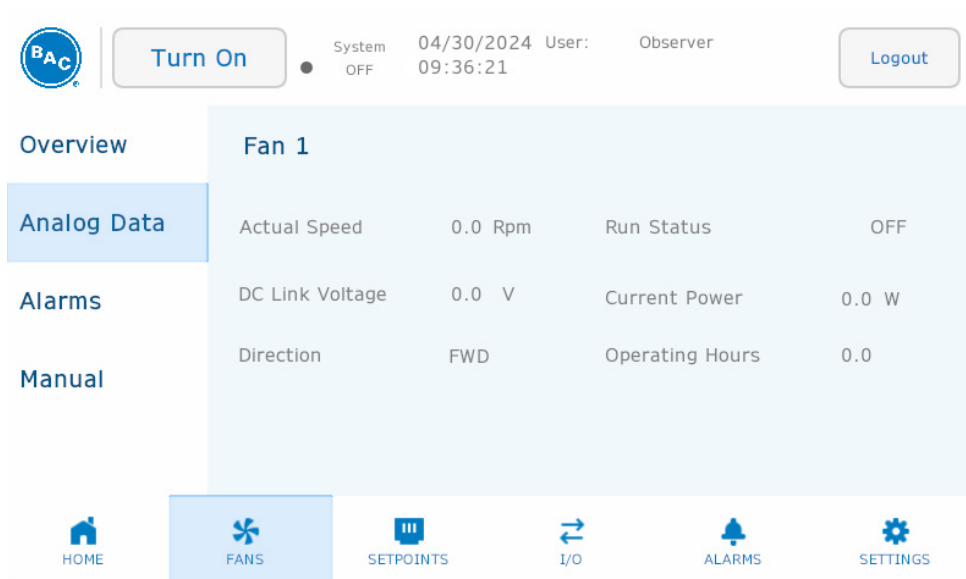

Figure 52. Fan X Menu, Analog Menu

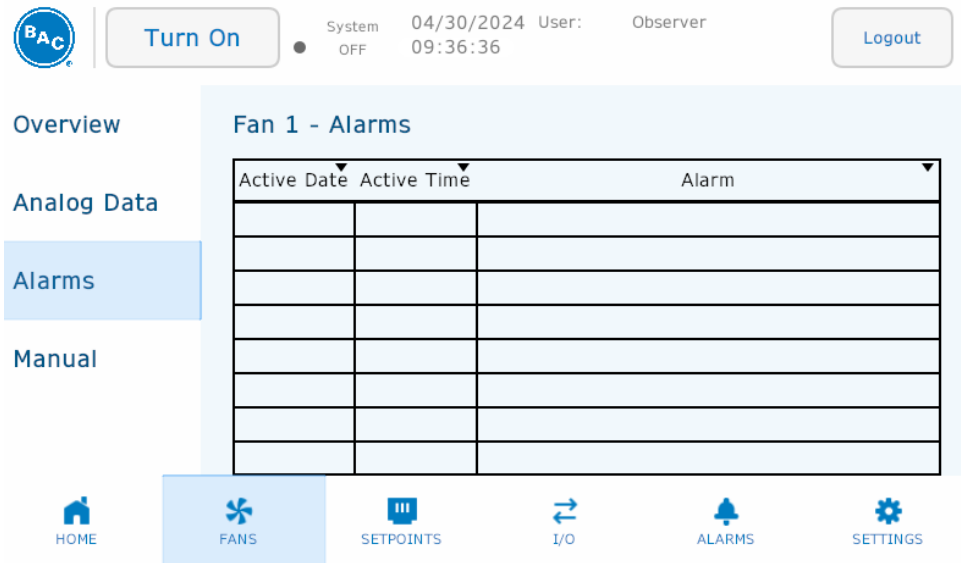

Figure 53. Fan X Menu, Alarms

Fan X Manual

The Manual menu shown in **Figure 54** is only visible with Technician access level. Refer to **Table 10. Access Levels and Passwords** on **Page 53**. Setting the Fan X Manual Mode to Enable will not transition the control state to Manual. The Manual menu allows a user to override the fan speed, fan rotation direction, start, stop or reset a fan.

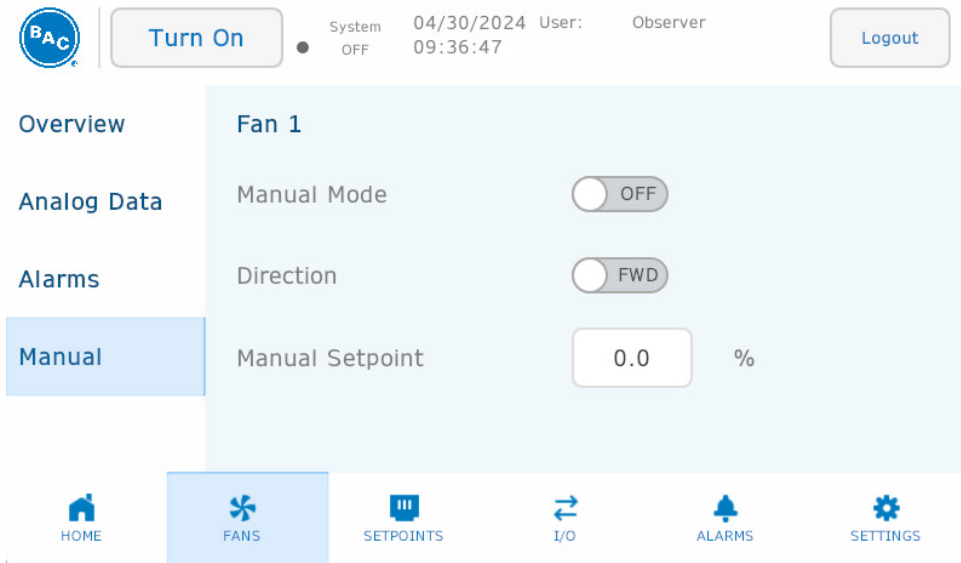

Figure 54. Fan X Menu, Manual

Setpoints

Leaving Fluid Control & Customer Input Control Menu

With the parameters that can be set in this menu, the user can finetune the behavior of the unit. The Leaving Fluid Control tab shown in **Figure 55** and **Figure 56** is only visible if the Control Type is Leaving Fluid Control. The Customer Input Control tab shown in **Figure 57** is only visible if the Control Type is Customer Input. The Customer Input Control mode allows the user to provide an analog input signal to control the unit's capacity between 0% and 100%. **Table 13** lists the parameters available in Setpoints menu, Leaving Fluid Control and Customer Input Control.

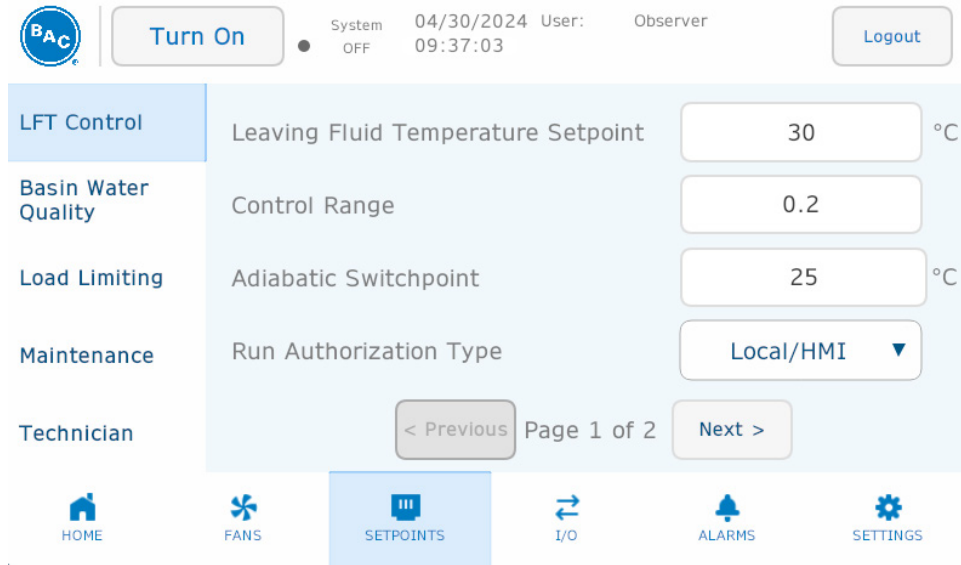

Figure 55. Setpoints Menu, Leaving Fluid Control, Page 1 of 2

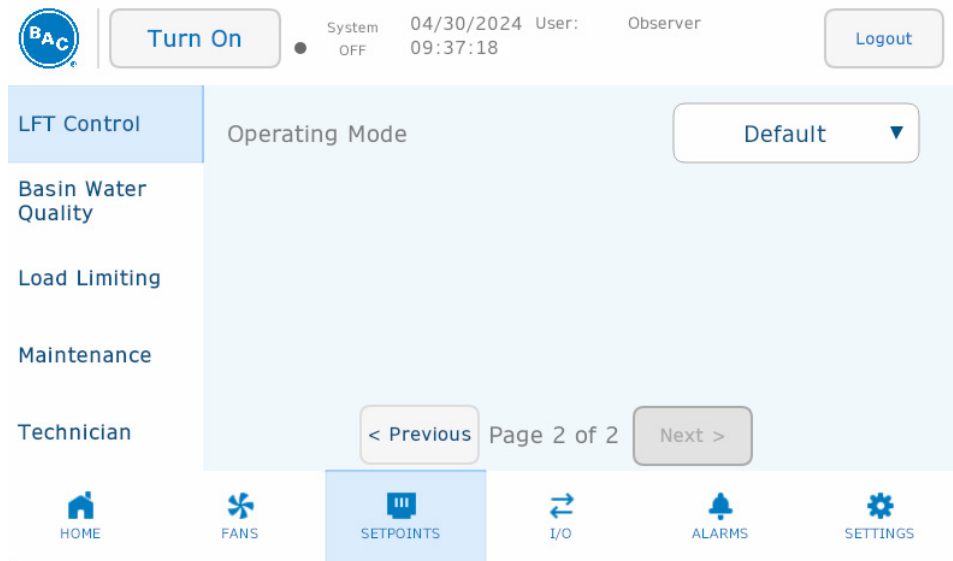

Figure 56. Setpoints Menu, Leaving Fluid Control, Page 2 of 2

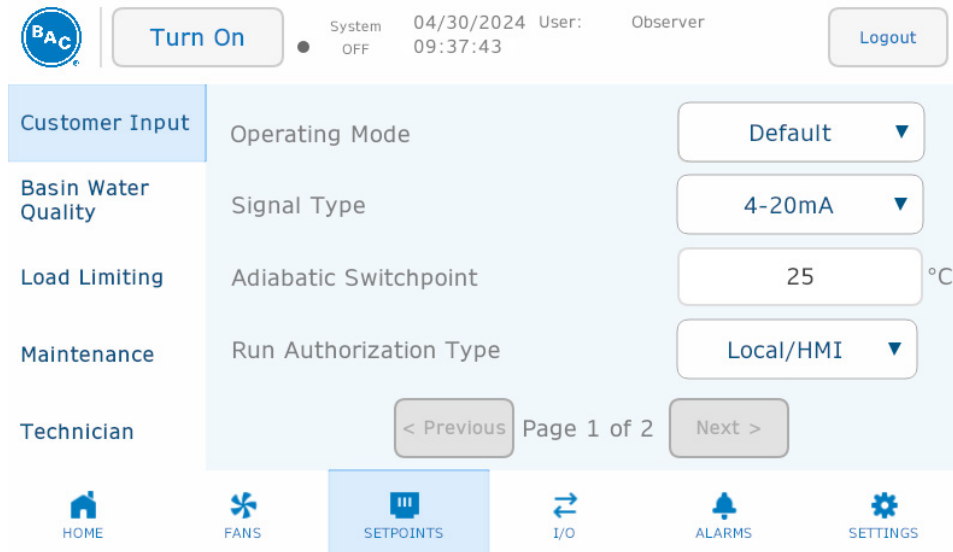

Figure 57. Setpoints Menu, Customer Input Control

Parameter	Description
Operating Mode: Default	Utilizes factory set operating variables that provides a balance of water and energy savings. See Table 14. Operating Mode Parameters for more information.
Operating Mode: Energy Saver	Energy Saver mode will enter adiabatic operation more quickly than Default or Water Saver Operating Modes resulting in lower fan power energy consumption. See Table 14. Operating Mode Parameters for more information.
Operating Mode: Water Saver	Water Saver mode will stay in dry operation longer than Default or Energy Saver Operating Modes resulting in lower water consumption. See Table 14. Operating Mode Parameters for more information.
Signal Type	Defines the type of input signal. This can be set to either 4-20mA, 0-10V, 10-0V or BMS 0-100%. The current and voltage signal is supplied to input channel AI8. The BMS signal refers to the “FanCIsetpoint” variable in Table 68 for Modbus and “CIsetpoint” variable in Table 72 for BACnet.
Leaving Fluid Temp Setpoint	Set-point for the fluid outlet temperature
Control Range	Allowed offset in leaving fluid temperature set point before changing stages/operating modes. For example, allows leaving fluid temperature to rise above leaving fluid temp setpoint by this control range before changing to adiabatic mode.
Adiabatic Switchpoint	Ambient temperature at which adiabatic operation becomes possible. Adiabatic Switchpoint on Page 14 for more details.
Run Authorization Type	Source signal to switch the unit between stand-by and active. This can be set to either HMI, digital input or BMS. HMI refers to the button on the top left of the screen, digital input refers to channel DI1, BMS refers to the “BMSrunEn” variable in Table 68 . The HMI button is always taken into account to enable the unit to run (also when the type is set to digital input or BMS).

Table 13. Setpoints Menu, Leaving Fluid/Customer Input Control Parameters

Parameter	Operating Mode		
	Default	Energy Saver	Water Saver
Control Range	X	X	X + 1
Adiabatic Switchpoint	X	lowers current setpoint by 5°C	X
Stage Timer	2 minutes	1 minute	5 minutes
	97%	70%	97%

Table 14. Operating Mode Parameters

Basin Water Quality Menu

The Basin Water Quality menu shown in **Figure 58** and **Figure 59** allows a user to adjust parameters shown in **Table 15**. **Figure 60** is available with Technician access.

Table 15. Setpoints Menu, Basin Water Quality Parameters

The image displays two screenshots of the BAC user interface. The top screenshot shows the 'Setpoints' menu for 'Basin Water Quality'. It includes a sidebar with navigation options: LFT Control, Basin Water Quality (selected), Load Limiting, Maintenance, and Technician. The main content area shows five adjustable parameters: Reading Delay (3.0 sec), Dead Band (10.0 mm), High Limit (165.0), Mid Limit (89.0 mm), and Low Limit (50.0). A navigation bar at the bottom of the menu shows '< Previous', 'Page 3 of 3', and 'Next >'. The bottom navigation bar includes icons for HOME, FANS, SETPOINTS (selected), I/O, ALARMS, and SETTINGS. The top status bar shows 'Turn On', System OFF, date 04/30/2024, time 10:07:53, and User: Observer with a Login button.

The bottom screenshot shows the 'Water Usage' menu. The sidebar is identical to the top screenshot. The main content area shows 'Water Usage' with a green dot and 'ON' status, and an 'Enable' toggle switch. Below are three adjustable parameters: Basin Retention Time (24 Hrs), Precooler 1 Run Hours (0 Hrs), and Precooler 2 Run Hours (0 Hrs). The navigation bar shows '< Previous', 'Page 1 of 3', and 'Next >'. The bottom navigation bar is the same as the top screenshot. The top status bar shows 'Turn On', System OFF, date 04/30/2024, time 09:38:24, and User: Observer with a Logout button.

Figure 58. Setpoints Menu, Basin Water Quality Page 1 of 3

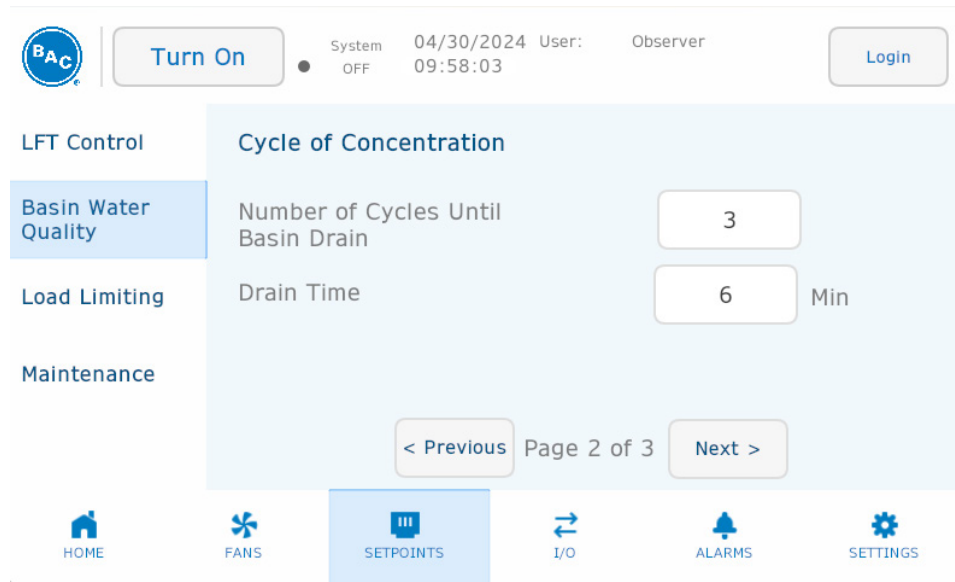



Figure 59. Setpoints Menu, Basin Water Quality Page 2 of 3

Parameter	Description
Disable Water Usage	Manually disable water usage (prevent adiabatic operation)
Basin Retention Time	Time after switch to dry operation before fully draining the water in the basin (sump). Low limit 1 hour, high limit 72 hours, default 24 hours.
Precooler X Run Hours	Number of adiabatic operating hours on each pre-cooler air inlet face
Number of Cycles Until Basin Drain	Number of cycles of concentration till basin (sump) drains and is replaced with make-up water. A cycle of concentration is defined as the basin water level starting at the High Level, down to the Mid Level, then back to the High Level. The loss of basin water is due to evaporation on the adiabatic pads. Low limit 3, high limit 10, default 3.
Drain Time	The number of minutes the basin will drain for the Cycles of Concentration.

Table 15. Setpoints Menu, Basin Water Quality Parameters

Turn On
System OFF
04/30/2024 10:07:53
User: Observer
Login

LFT Control
Basin Water Quality
Load Limiting
Maintenance
Technician

Reading Delay	<input type="text" value="3.0"/>	sec
Dead Band	<input type="text" value="10.0"/>	mm
High Limit	<input type="text" value="165.0"/>	
Mid Limit	<input type="text" value="89.0"/>	mm
Low Limit	<input type="text" value="50.0"/>	

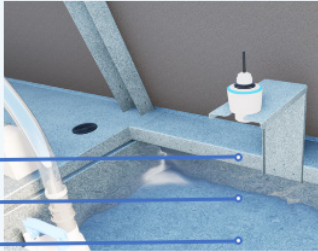

< Previous Page 3 of 3 Next >

HOME
FANS
SETPOINTS
I/O
ALARMS
SETTINGS

Figure 60. Setpoints Menu, Basin Water Quality Page 3 of 3

Load Limiting Menu

Refer to section **Load Limiting Modes** on **Page 15** for more information. The Load Limiting menu includes:

- Night Quiet load limiting mode shown in **Figure 61** and **Figure 62** with parameters listed in **Table 16**.
- Night Dry load limiting mode shown in **Figure 64** and **Figure 65** with parameters listed in **Table 17**.
- Schedule Dry load limiting mode shown in **Figure 67** and **Figure 68** with parameters listed in **Table 18**.

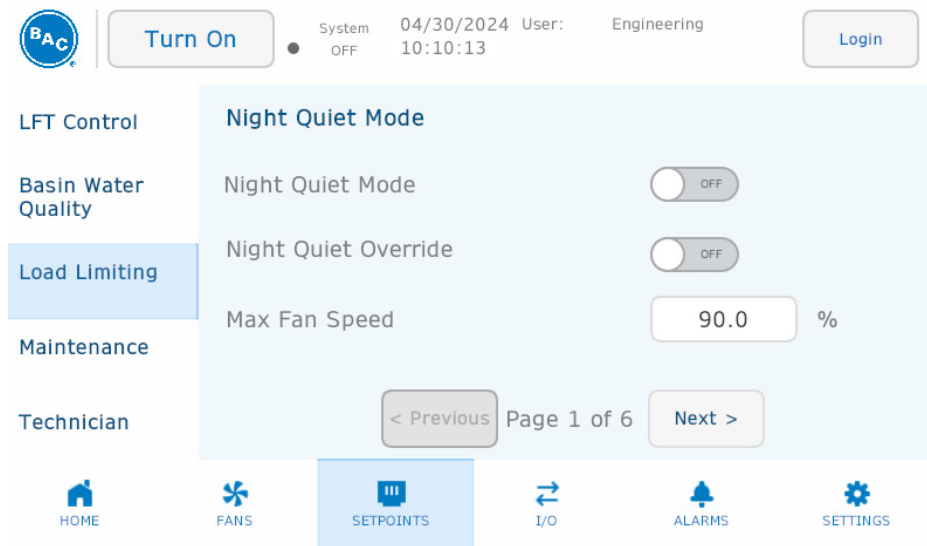

Figure 61. Setpoints Menu, Load Limiting Page 1 of 6

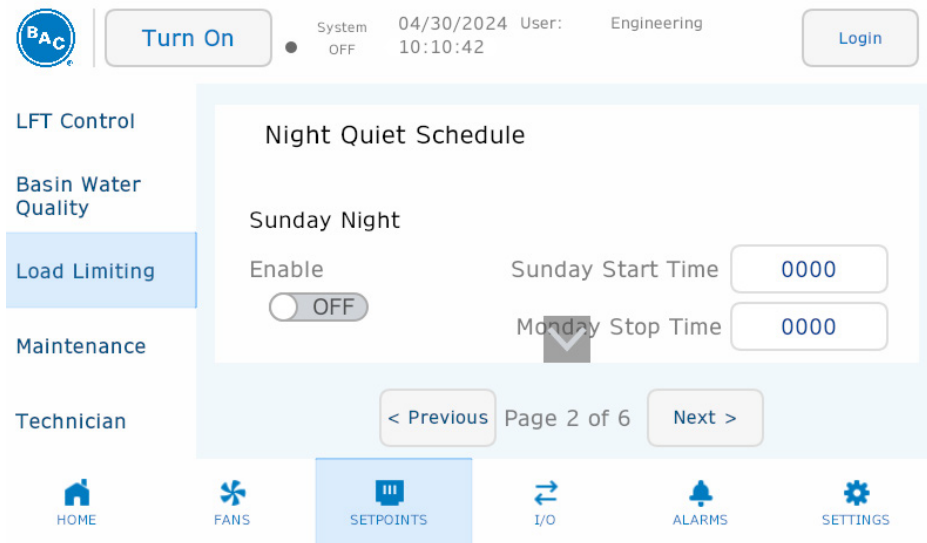

Figure 62. Setpoints Menu, Load Limiting Page 2 of 6

In the above menu, clicking the down arrow in the grey box shall display more options. The user can also click and drag the menu up and down to see more. **Figure 63** is the full display of that menu.

Figure 63. Setpoints Menu, Load Limiting Full List, Page 2 of 6

Parameter	Description
Night Quiet Enable/Disable	Allows use to either enable or disable the feature. If enabled, the “max fan speed” and “adiabatic switchpoint” parameters will become active during the times set in the schedule shown in Figure 62 .
Max Fan Speed	Maximum fan speed that needs to be observed when “night quiet” mode is active
Night Quiet Override	If enabled, the “max fan speed” and “adiabatic switchpoint” parameters will become active regardless of the schedule shown in Figure 62 . In addition to the on-screen button, the override can also be enabled with the “NightQuietOverride” variable in Table 71
Night Quiet Schedule	The schedule defines a start time on one day and a stop time on the next day. All times are in 24-hour format.

Table 16. Setpoints Menu, Load Limiting Night Quiet Parameters

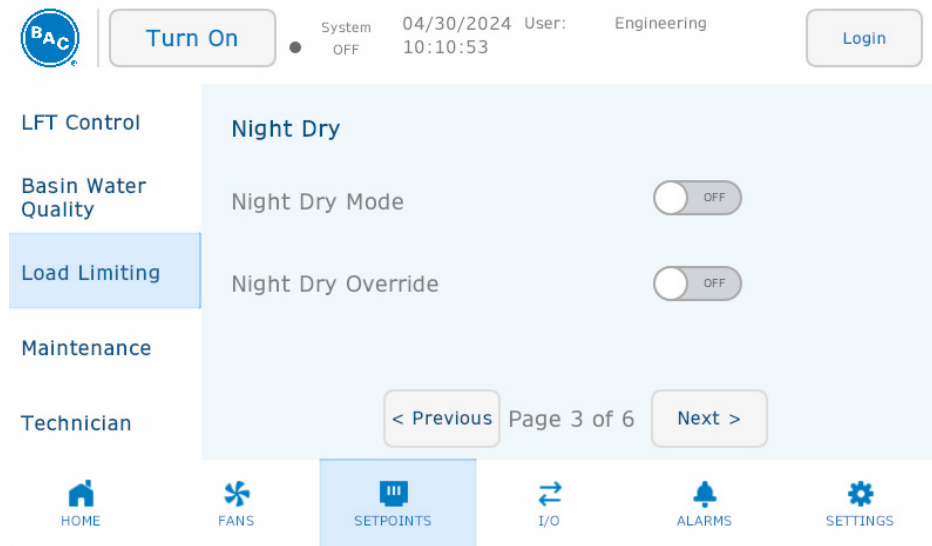

Figure 64. Setpoints Menu, Load Limiting Page 3 of 6

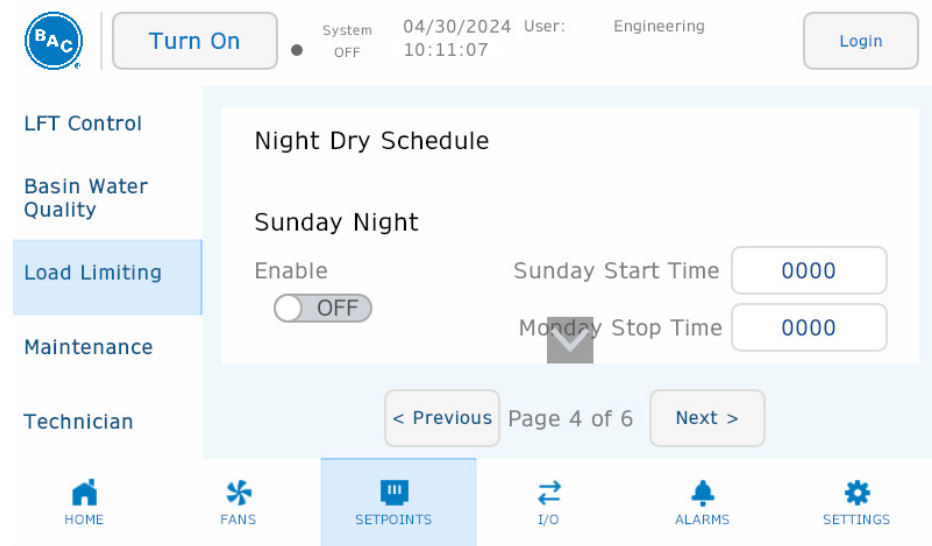

Figure 65. Setpoints Menu, Load Limiting Page 4 of 6

In the above menu, clicking the down arrow in the grey box shall display more options. The user can also click and drag the menu up and down to see more. **Figure 66** is the full display of that menu.

The screenshot displays a configuration menu for 'Load Limiting' with seven sections, one for each day of the week. Each section includes an 'Enable' toggle (currently set to 'OFF') and two time input fields. The 'Start Time' for all days is set to 1530, and the 'Stop Time' is set to 615. The sections are: Sunday Night, Monday Night, Tuesday Night, Wednesday Night, Thursday Night, Friday Night, and Saturday Night.

Figure 66. Setpoints Menu, Load Limiting, Full List Page 4 of 6

Parameter	Description
Night Dry Enable/Disable	Allows user to either enable or disable the feature. If enabled, no water will be used during the times set in the schedule shown in Figure 65 .
Night Dry Override	If enabled, no water will be used regardless of the schedule shown in Figure 65 . In addition to the on-screen button, the override can also be enabled with the “NightDryOverride” variable in Table 71 .
Night Dry Schedule	The schedule defines a start time on one day and a stop time on the next day. All times are in 24-hour format.

Table 17. Setpoints Menu, Load Limiting Night Dry Parameters

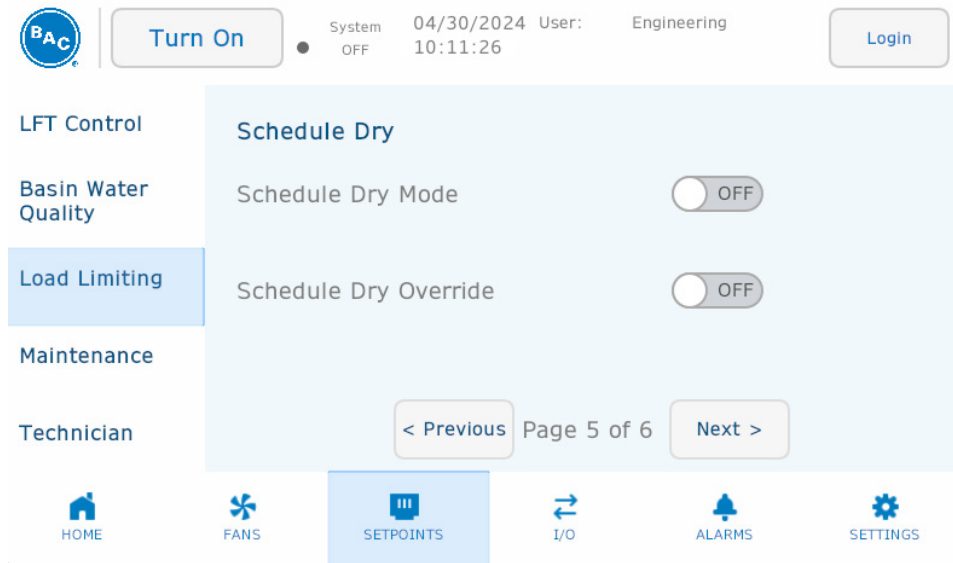

Figure 67. Setpoints Menu, Load Limiting Page 5 of 6

Parameter	Description
Schedule Dry Enable/Disable	Allows user to either enable or disable the feature. If enabled, no water will be used during the times set in the schedule shown in Figure 68 .
Schedule Dry Override	If enabled, no water will be used regardless of the schedule shown in Figure 68 . In addition to the on-screen button, the override can also be enabled with the “ScheduleDryOverride” variable in Table 71 .
Schedule Dry Schedule	The schedule defines a start time on one day and a stop time on the same day. All times are in 24-hour format.

Table 18. Setpoints Menu, Load Limiting Schedule Dry Parameters

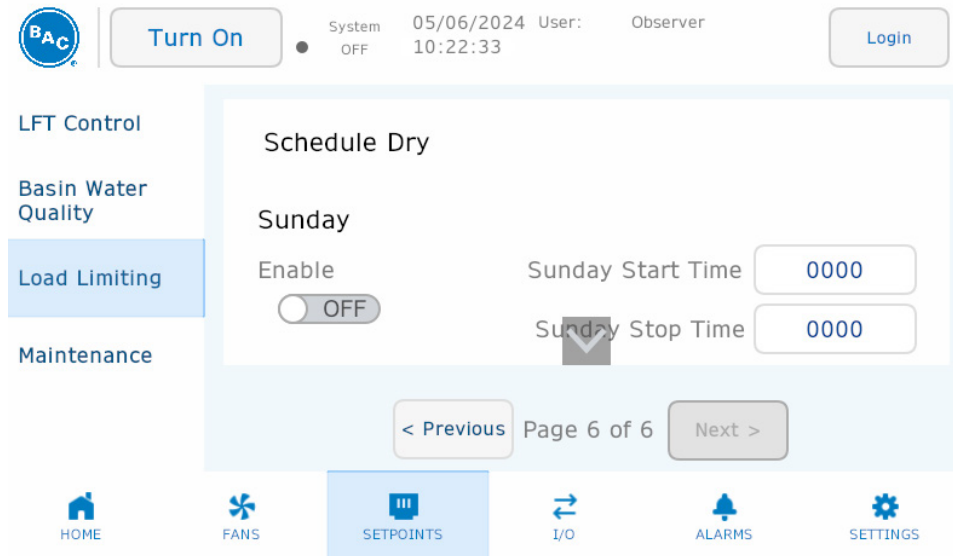

Figure 68. Setpoints Menu, Load Limiting Page 6 of 6

In the above menu, clicking the down arrow in the grey box shall display more options. The user can also click and drag the menu up and down to see more. **Figure 69** is the full display of that menu.

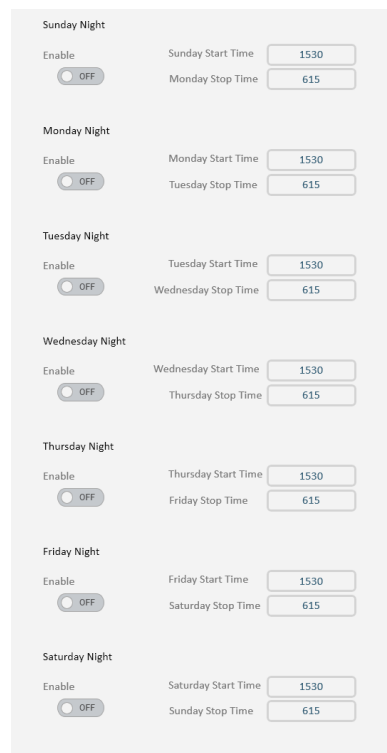

Figure 69. Setpoints Menu, Load Limiting, Full List Page 6 of 6

Maintenance Menu

Refer to section **Maintenance Modes** on **Page 15** for more information. The Maintenance menu includes

- Coil Clean maintenance mode shown in **Figure 70** and **Figure 71** with parameters listed in **Table 19**.
- Pad Clean maintenance mode shown in **Figure 72** and **Figure 73** with parameters listed in **Table 20**.
- Drain and Dry maintenance mode shown in **Figure 74** and **Figure 75** with parameters listed in **Table 21**.

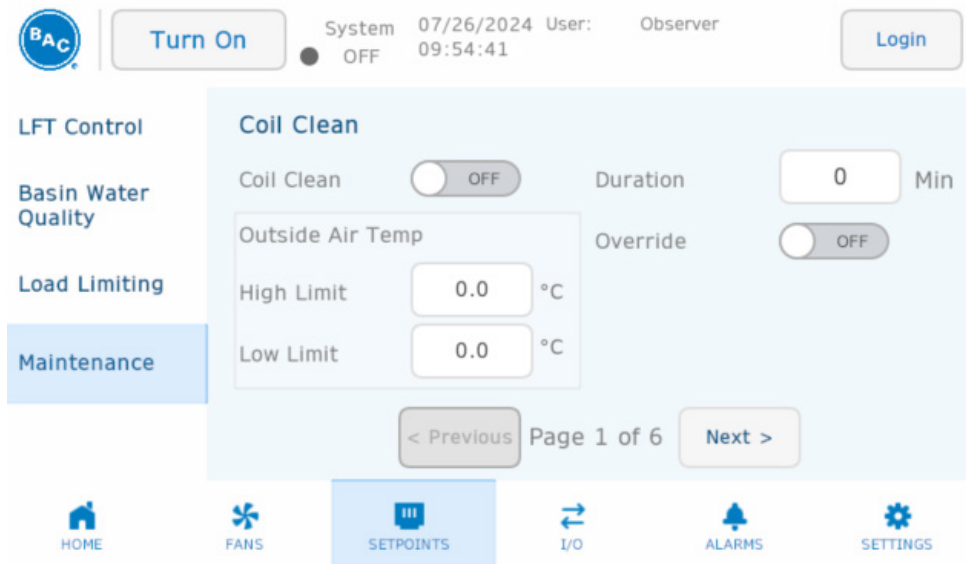

Figure 70. Setpoints Menu, Maintenance Page 1 of 6

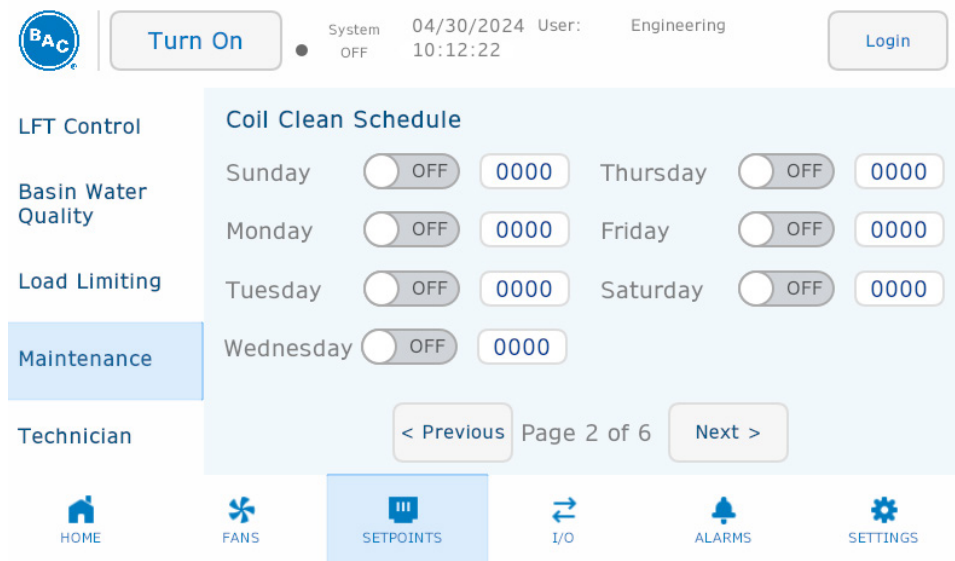

Figure 71. Setpoints Menu, Maintenance Page 2 of 6

Parameter	Description
Coil Clean Enable/Disable	Allows user to either enable or disable the feature. If enabled, the fans will do a daily cycle at a 100% fan speed in reverse direction at the time programmed.
Cleaning High Limit Temp	Maximum ambient temperature at which all maintenance functions can start. Because the fans run in reverse, they will push warm ambient air over the coils in summer.
Cleaning Low Limit Temp	Minimum ambient temperature at which the coil cleaning cycle can start. Because the fans run at maximum fan speed, there would be an undercooling and/or coil freezing risk if allowed to become too low.
Coil Clean Duration	Time in seconds the coil cleaning cycle lasts
Time Between Coil Clean	Number of hours between coil cleaning cycles
Coil Clean Start Time	Time of the day when the coil cleaning cycle will start

Table 19. Setpoints Menu, Coil Clean Parameters

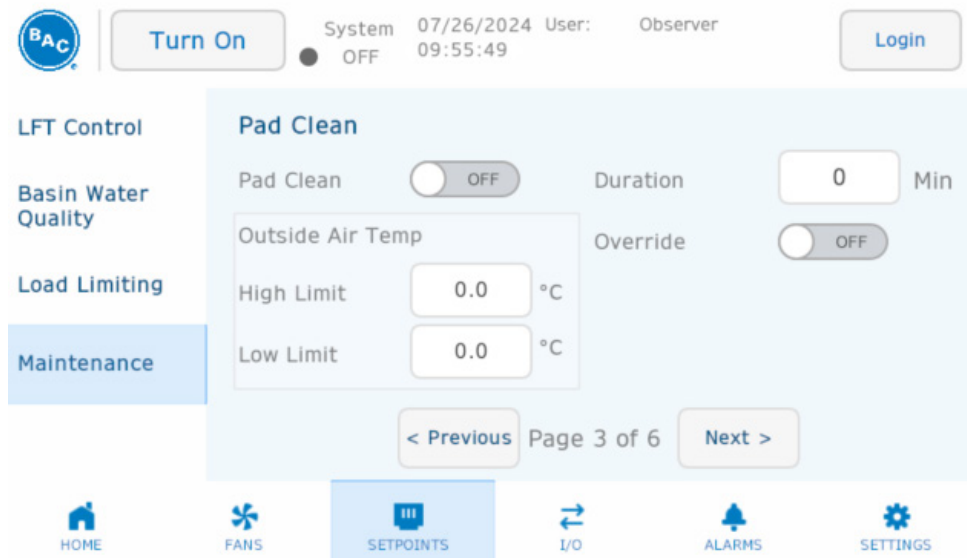

Figure 72. Setpoints Menu, Maintenance Page 3 of 6

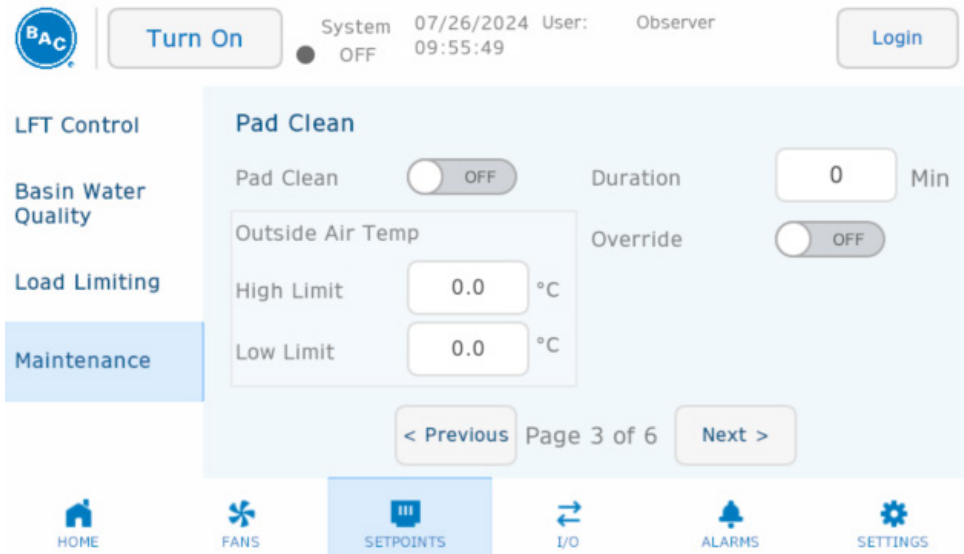

Figure 73. Setpoints Menu, Maintenance Page 4 of 6

Parameter	Description
Pad Clean Enable/Disable	Allows user to either enable or disable the feature. If enabled, the pads will be rinsed at the time programmed.
Pad Clean Duration	Time in seconds the pad cleaning cycle lasts.
Time Between Pad Cleans	Number of hours between pad cleaning cycles
Pad Clean Start Time	Time of the day when the pad cleaning cycle will start, preferably set in the afternoon to take advantage of the increased cooling effect during the warmest period of the day.

Table 20. Setpoints Menu, Pad Clean Parameters

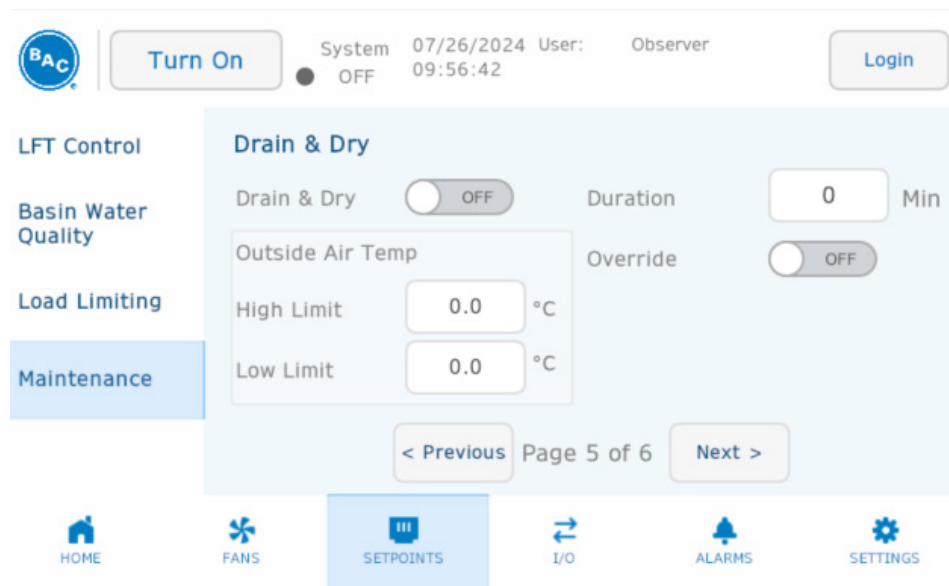

Figure 74. Setpoints Menu, Maintenance Page 5 of 6

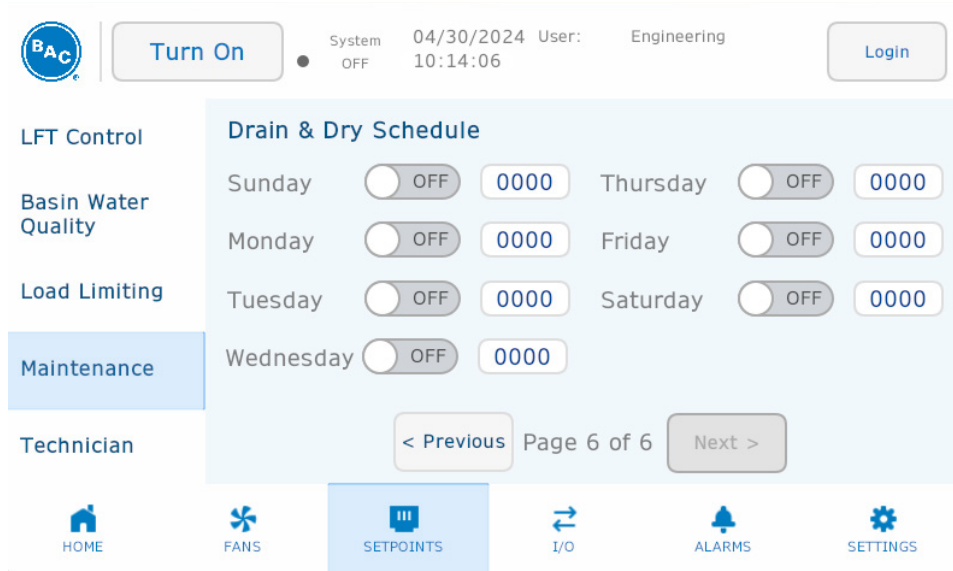

Figure 75. Setpoints Menu, Maintenance Page 6 of 6

Parameter	Description
Drain and Dry Enable/Disable	Allows user to either enable or disable the feature. If enabled, the fans will do a daily cycle at a 100% fan speed at the time programmed.
Drain and Dry Duration	Time in seconds the drain and dry cycle lasts.
Time Between Drain and Dry	Number of hours between pad drain and dry cycles.
Drain and Dry Start Time	Time of the day when the drain and dry cycle will start.

Table 21. Setpoints Menu, Complete Drain and Dry Parameters

Technician Menu

The Technician menus shown in **Figure 76** and **Figure 77** are only visible with Technician access level. Refer to **Table 10** on **Page 53**. Technician menu parameters are shown in **Table 37**. Note that changing the PI (proportional and integration) parameters or stage time may result in a hunting phenomenon.

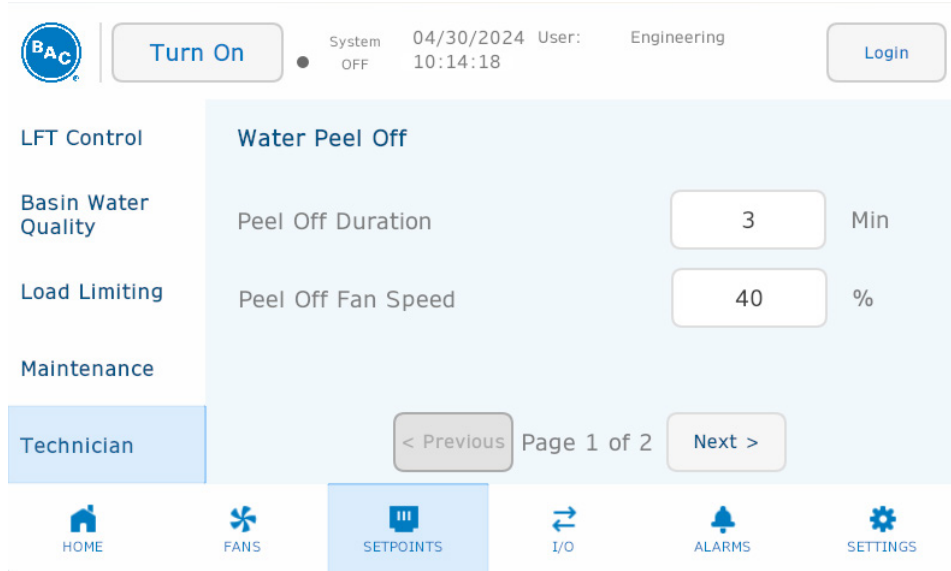

Figure 76. Setpoints Menu, Technician, Page 1 of 2

Parameter	Description
Peel Off Duration	Amount of time in which the Fan speed will be limited when transitioning to Wet Mode.
Peel Off Fan Speed	Fan Speed at which the fans will be limited to when transitioning to Wet Mode.

Table 22: Setpoints Menu, Water Peel Off

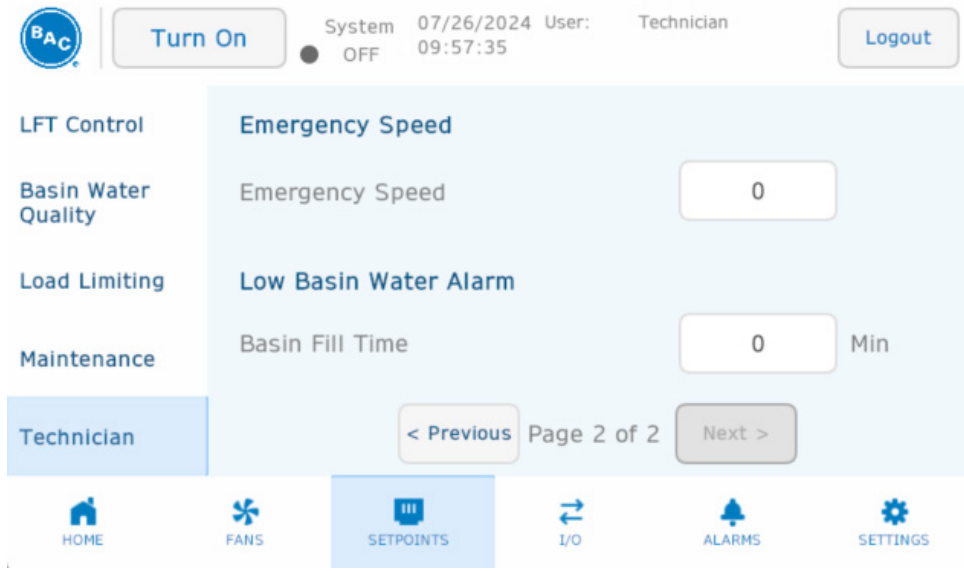

Figure 77. Setpoints Menu, Technician, Page 2 of 2

Parameter	Description
Emergency Speed	The command at which the Fans will run when entering the Emergency State

Table 23: Setpoints Menu, Emergency Speed

Input & Output

With the parameters that can be set in this menu, the user can view the status of all available inputs and outputs. In addition, some output signals can be forced in a certain position to overrule the default programming.

Temperatures Menu

Temperature menu is shown in **Figure 78** and **Figure 79** with parameters listed in **Table 24**. **Figure 79** only appears if the Precool Temp Sensor option is provided on the unit.

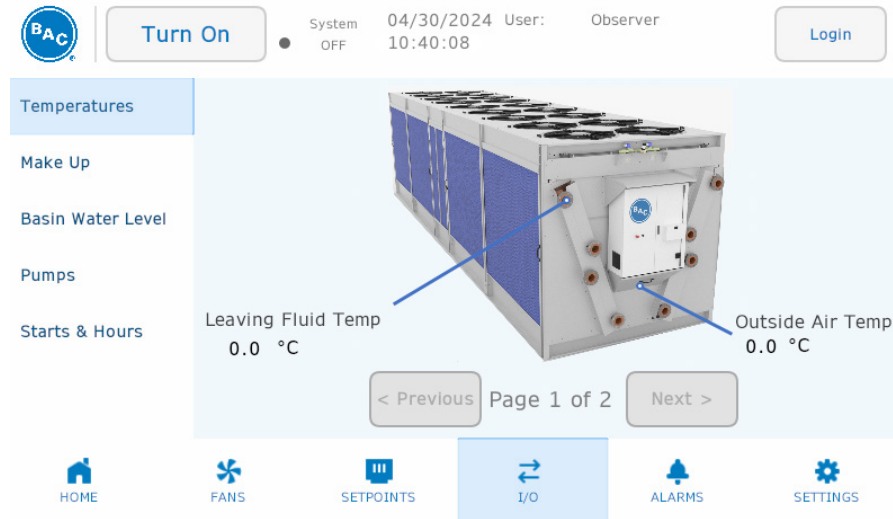

Figure 78. I/O Menu, Temperature Page 1 of 2

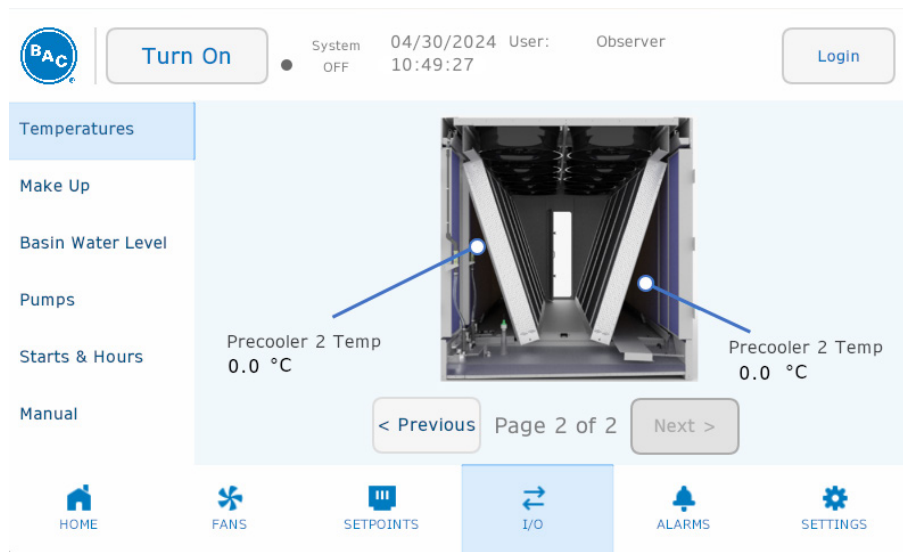

Figure 79. I/O Menu, Temperature Page 2 of 2

Parameter	Description
Leaving Fluid Temp	Process fluid temperature
Outside Air Temp	Ambient dry bulb temperature
Precool X Temp	Depressed dry bulb temperature behind the adiabatic pre-cooler section.

Table 24. I/O Menu, Temperature Parameters

Make Up Menu

Make Up menu is shown in **Figure 80** with parameters listed in **Table 25**.

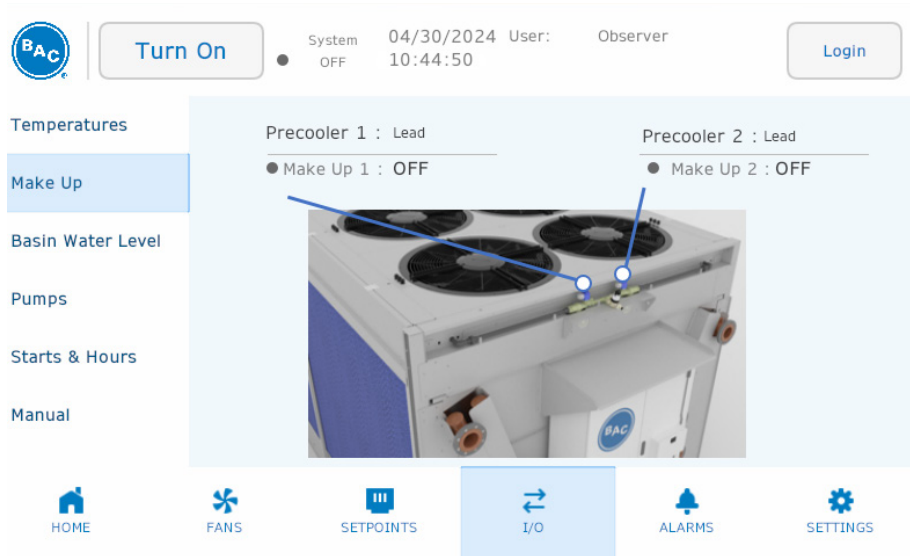

Figure 80. I/O Menu, Make Up

Parameter	Description
Precooler X	Indication if the makeup valves are open or closed.

Table 25. I/O Menu, Make Up Parameters

Basin Water Level Menu

Basin Water Level menu is shown in **Figure 81** with parameters listed in **Table 26**.

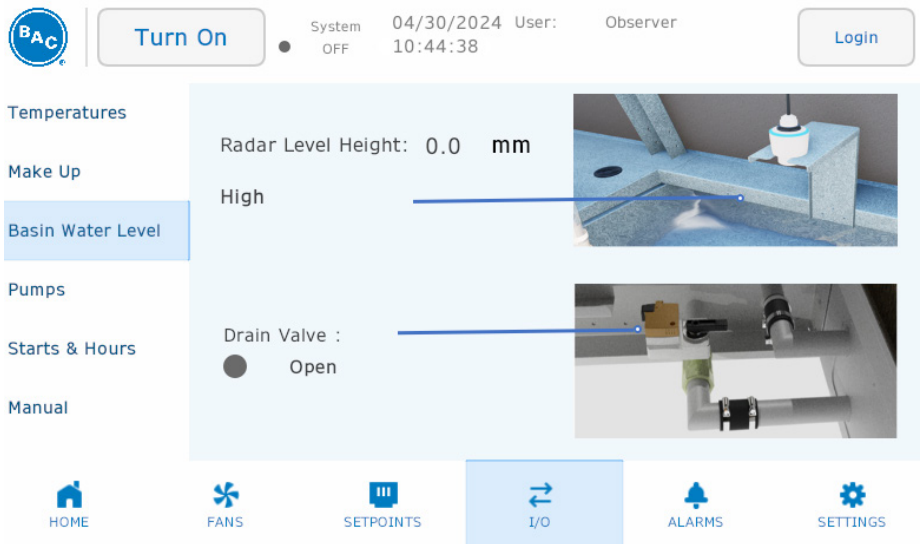

Figure 81. I/O Menu, Basin Water Level

Parameter	Description
Basin Water Level	Status indication of the sump water level sensor.
Drain Valve	Indication if the valve is open (water draining from the sump) or closed (keeping water in the sump)

Table 26. I/O Menu, Basin Water Level Parameters

Pumps Menu

Pumps menu is shown in **Figure 82** with parameters listed in **Table 27**.

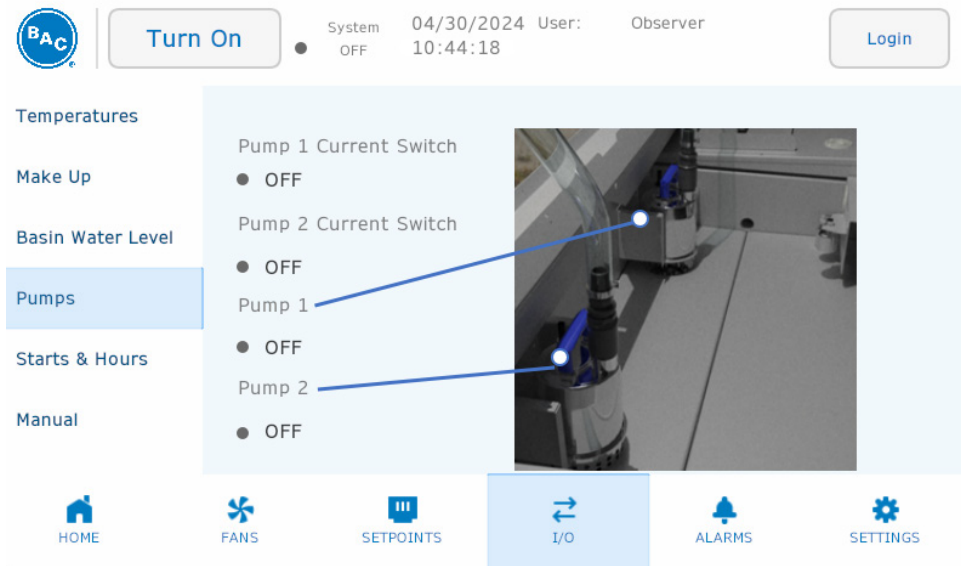

Figure 82. I/O Menu, Pumps

Parameter	Description
Pump X Current Switch	Indication if the pump is properly running (current detected) or not (no current). The current switch gives an indication of electrical current.
Pump X	Indication if the pump is On or Off.

Table 27. I/O Menu, Pumps Parameters

Starts and Hours Menu

The Starts and Hours menu is shown in **Figure 83** through **Figure 85** with parameters listed in **Table 28**. Here, the number of starts and operating hours can be reviewed. Pressing the “Reset” button resets the starts and hours for the corresponding device. A reset can only be done with Technician level access. Refer to **Table 10** on **Page 53**.

System OFF 04/30/2024 10:57:52 User: Observer

	Starts:	Hours:
Precooler 1 :	0	0
Precooler 2 :	0	0

< Previous Page 1 of 3 Next >

Figure 83. I/O Menu, Starts and Hours Page 1 of 3

System OFF 04/30/2024 10:58:04 User: Observer

	Starts:	Hours:	
Make Up 1 :	0	0	Reset
Make Up 2 :	0	0	Reset

< Previous Page 2 of 3 Next >

Figure 84. I/O Menu, Starts and Hours Page 2 of 3

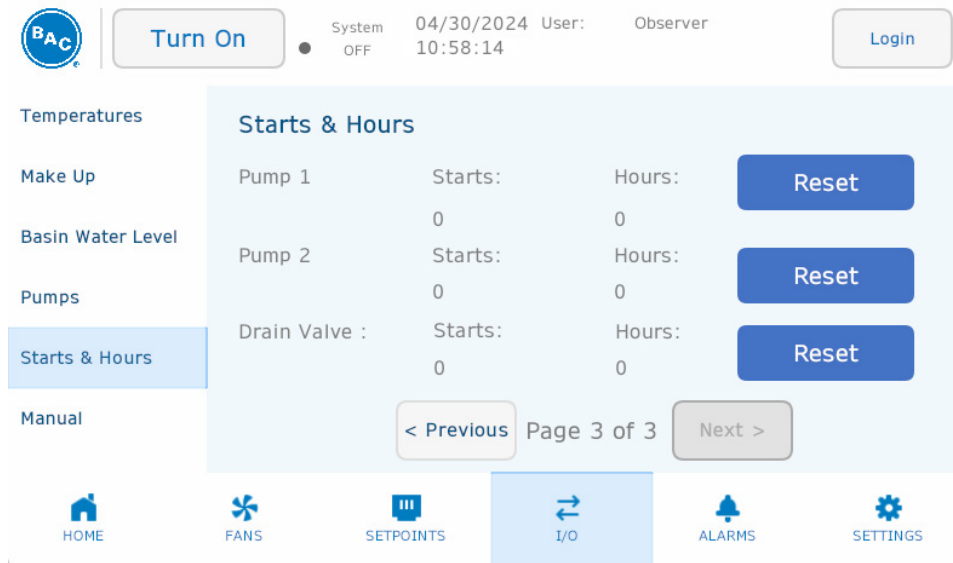

Figure 85. I/O Menu, Starts and Hours Page 3 of 3

Parameter	Description
Precooler X	Number of starts and operating hours the unit is in adiabatic operation.
MUPX	Number of starts and operating hours for each make up valve.
Drain Valve	Number of starts and operating hours for drain valve.
Pump X	Number of starts and operating hours for each pump.

Table 28. I/O Menu, Starts and Hours Parameters

Manual Menu

The Manual menu will display only with Technician level access. Refer to **Table 10** on **Page 53**. The Manual menu is shown in **Figure 86** and **Figure 87** with parameters listed in **Table 29**. In this menu, the position of a number of digital outputs can be overruled. Each digital output manual mode must be set to On in order to override the applicable value.

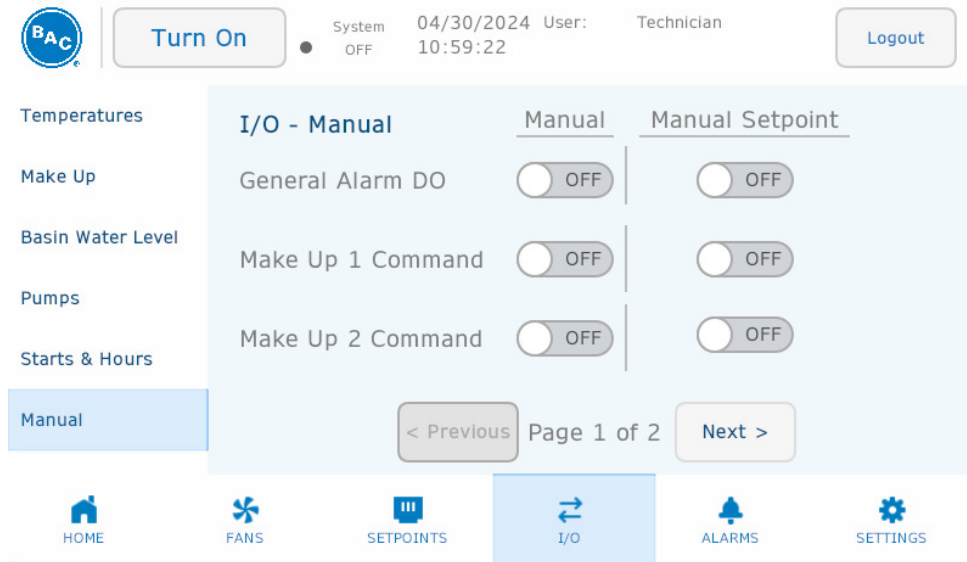

Figure 86. I/O Menu, Manual Page 1 of 2

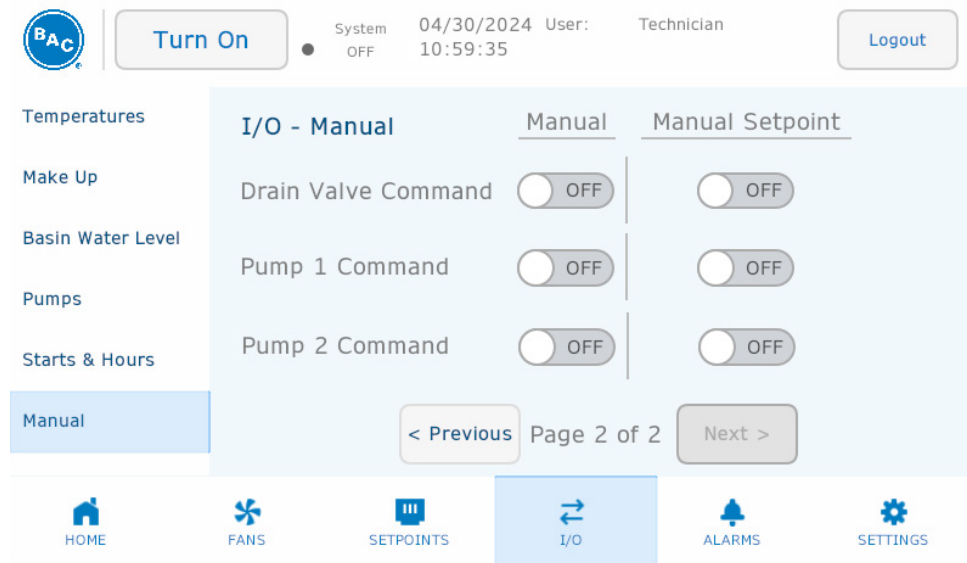

Figure 87. I/O Menu, Manual Page 2 of 2

Parameter	Description
Makeup Valve X	Force either make-up valve on or off.
Pump X Contact	Force either pump on or off.
Drain Valve	Force the drain valve open or closed.
General Alarm	Force the general alarm contact on or off.

Table 29. I/O Menu, Manual Parameters

Alarms

This menu allows a user to read and clear alarms. The alarm menu is shown in **Figure 88** with parameters listed in **Table 30**. All active alarms are highlighted in red; inactive alarms are not highlighted. **Figure 90** displays all alarms that have occurred since the last time the history had been cleared. For a detailed overview of the different alarms, see **Section 11. Alarms & Troubleshooting** on **Page 106**.

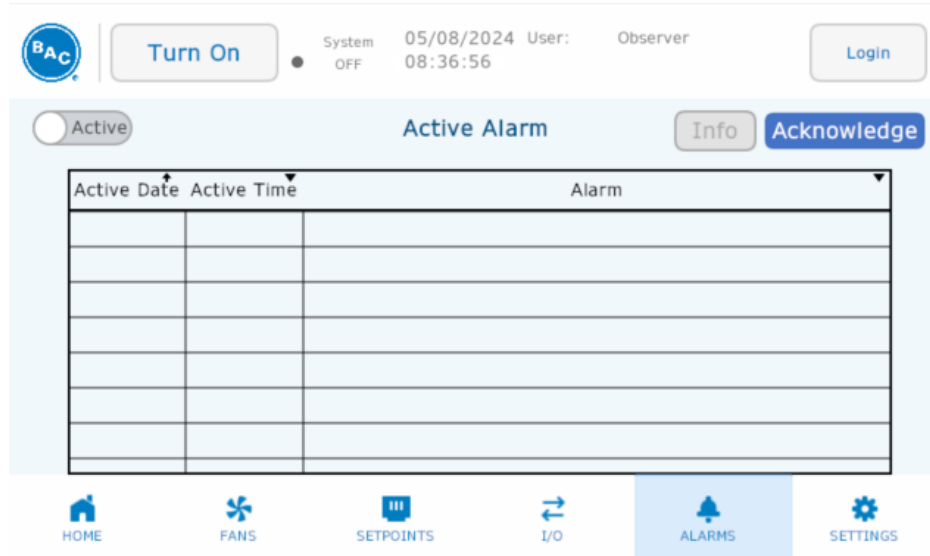

Figure 88. Alarms Menu, Active Alarms

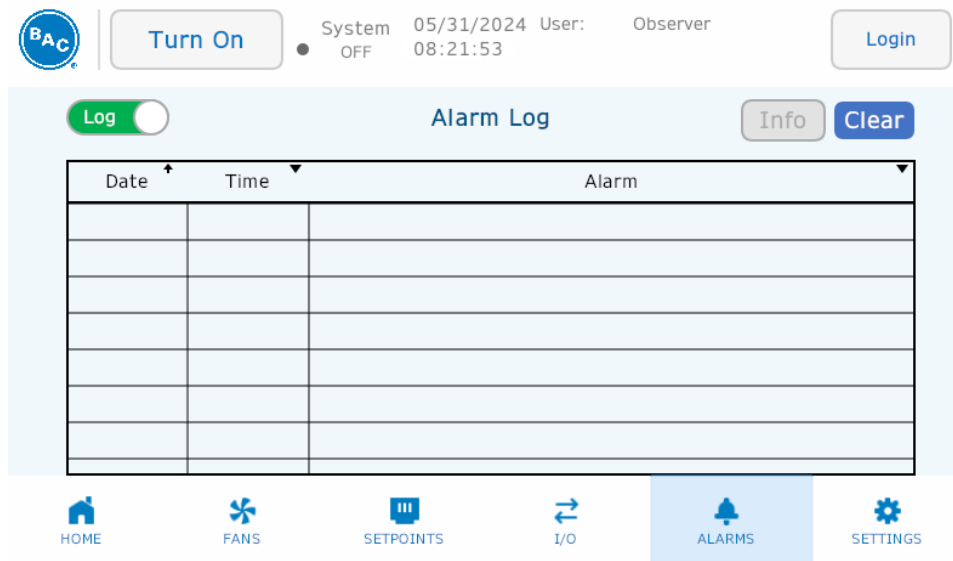

Figure 89. Alarms Menu, Alarm Log

Parameter	Description
Acknowledge	To acknowledge an alarm, select the active alarm to be acknowledge then press the “Acknowledge” button.
Information	Pressing the Info button in the upper left-hand corner shall toggle the screen to display the log or active alarms menu.
Clear	Pressing the Clear button will clear the Alarm history log.

Table 30. Alarm Menu Parameters

Alarm Details Page

Figure 90 is an example of the Alarm Details page. All possible alarms are listed in Table 43 through Table 64. There are 3 buttons on the left-hand side labeled Trigger, Release, and Troubleshooting. Pressing any of these buttons displays the respective information in the table for each alarm. Pressing the “Back” button returns the user to the Alarms menu. Figure 91 is an example of the Troubleshooting page.

The screenshot shows the 'Alarm Details' page for a 'Low Leaving Fluid Temperature Alarm'. At the top left is the BAC logo. To its right is a 'Turn On' button, a system status indicator (OFF), and the date/time '01/23/2023 12:23:46'. Further right is the user name 'Observer' and a 'Login' button. The main content area has a title 'Low Leaving Fluid Temperature Alarm'. On the left side of this area are three buttons: 'Trigger', 'Release', and 'Troubleshooting'. The central text area contains the following information:

The unit shall issue the alarm when any of the following are true:

- Control Type = LFT Ctrl AND Fluid Type = Water AND Leaving Fluid Temperature < 10 °C for 3 consecutive seconds
- Control Type = LFT Ctrl AND Fluid Type = Glycol AND Leaving Fluid Temperature < 7.2 °C for 3 consecutive seconds

A 'Back' button is located at the bottom right of the main content area. At the bottom of the page is a navigation bar with icons and labels for HOME, FANS, SETPOINTS, I/O, ALARMS (which is highlighted), and SETTINGS.

Figure 90. Alarms Menu, Alarm Details Page

The screenshot shows the 'Alarm Troubleshooting' page for the same 'Low Leaving Fluid Temperature Alarm'. The top navigation elements (BAC logo, Turn On button, system status, date/time, user name, and Login button) are identical to Figure 90. The main content area has the same title 'Low Leaving Fluid Temperature Alarm'. On the left side are the same three buttons: 'Trigger', 'Release', and 'Troubleshooting'. The central text area contains the following information:

Please verify the following:

1. Check Leaving Fluid Temperature sensor installation
2. Check Leaving Fluid Temperature sensor and wiring

A 'Back' button is located at the bottom right of the main content area. The bottom navigation bar is also identical to Figure 90, with the 'ALARMS' icon highlighted.

Figure 91. Alarms Menu, Alarm Troubleshooting Page

Settings

With the parameters that can be set in this menu, the user can configure the behavior of the unit.

Setup Menu

The Setup menu is shown in **Figure 92** and **Figure 93** with parameters listed in **Table 31**.

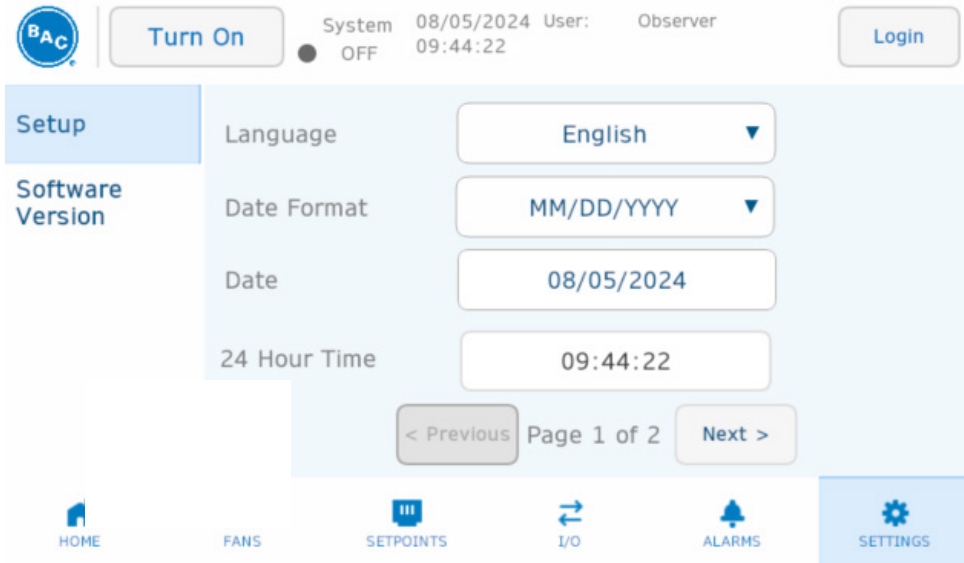

Figure 92. Settings Menu, Setup Page 1 of 2

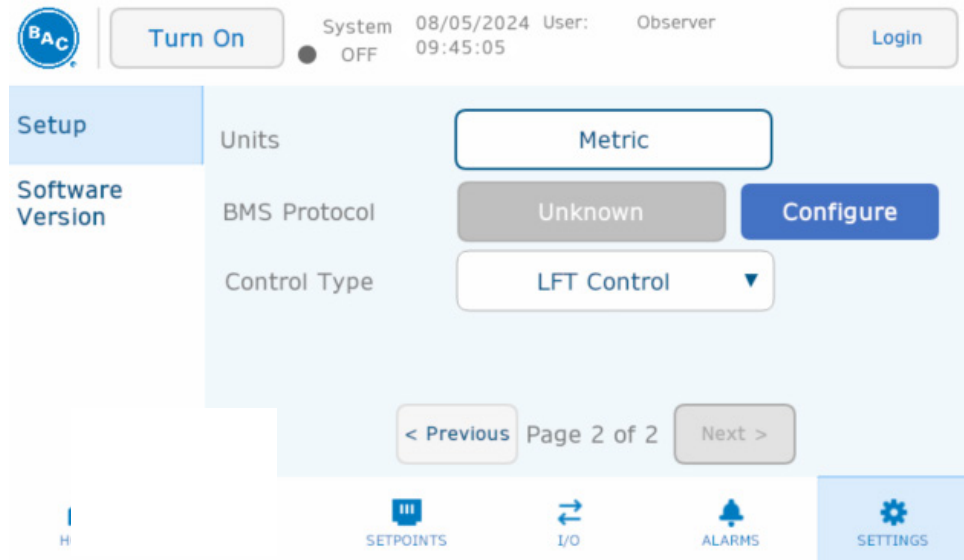

Figure 93. Settings Menu, Setup Page 2 of 2

Parameter	Description
Language	Determines the interface language.
Units	Determines the units of measurements for the different variables. This can be set to either SI or imperial.
Date Format	Determines in what order the day, month and year are shown. This can be set at MM/DD/YYYY, DD/MM/YYYY or YYYY/MM/DD.
Date	Allows user to change the current date (in the format chosen above).
24 Hour Time	Allows user to change the current time.
BMS Protocol	Select and configure the BMS bus system. Options are Modbus RTU, BACnet MSTP, BACnet IP & Modbus TCP. Pressing the “Configure” button displays the corresponding BMS Protocol Settings menu as shown in Figure 94 through Figure 101
Touchscreen	Pressing the “Calibrate” button above displays the touchscreen calibration screen and allow the user to calibrate the resistive touchscreen.
IP Address	Sets the correct value (in IPv4 format).
Subnet Mask	Sets the correct value (in IPv4 format).
Default Gateway	Sets the correct value (in IPv4 format).

Table 31. Settings Menu, Setup Parameters

Modbus RTU Setup

Selecting BMS Protocol Modbus RTU from the Setup menu shown in **Figure 93** and pressing the “Configure” button displays the Modbus RTU setup menu shown in **Figure 94** and **Figure 95** with parameters listed in **Table 32**.

Figure 94. Settings Menu, Modbus RTU Configuration

Figure 95. Settings Menu, Modbus RTU Serial Port

Parameter	Description
Modbus Address	Sets the units' network address
Baud Rate	Set the appropriate baud rate. Possible values (in kbps) are 9.6, 19.2, 38.4, 57.6 or 115.2
Data Bits	The number of data bits is always 8
Stop Bits	The number of stop bits always 1
Parity	The parity is always none

Table 32. Settings Menu, Modbus RTU Parameters

BACnet MSTP Setup

Selecting BMS Protocol BACnet MSTP from the setup menu shown in **Figure 93** and pressing the “Configure” button displays the BACnet MSTP setup menu shown in **Figure 96** and **Figure 97** with parameters listed in **Table 33**.

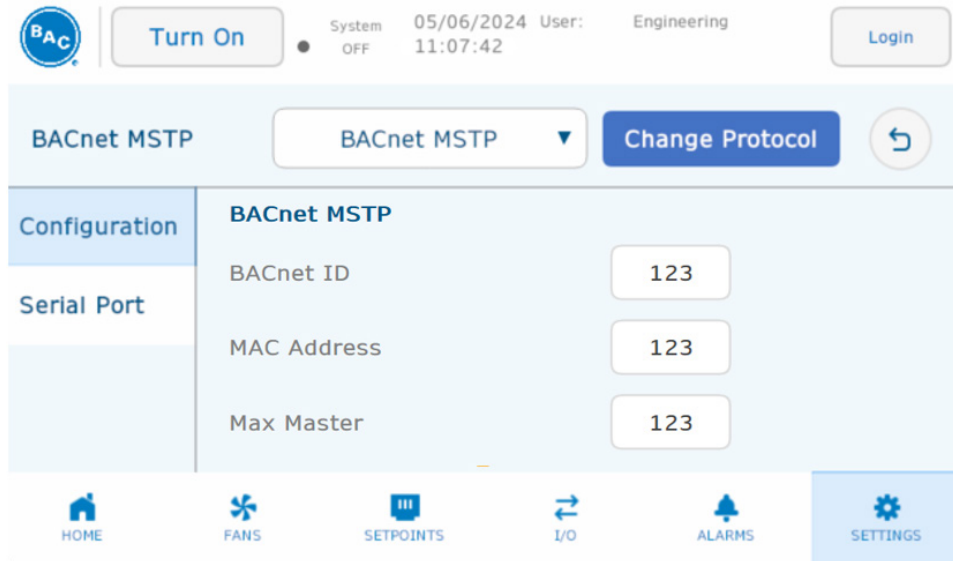

Figure 96. Settings Menu, BACnet MSTP Configuration

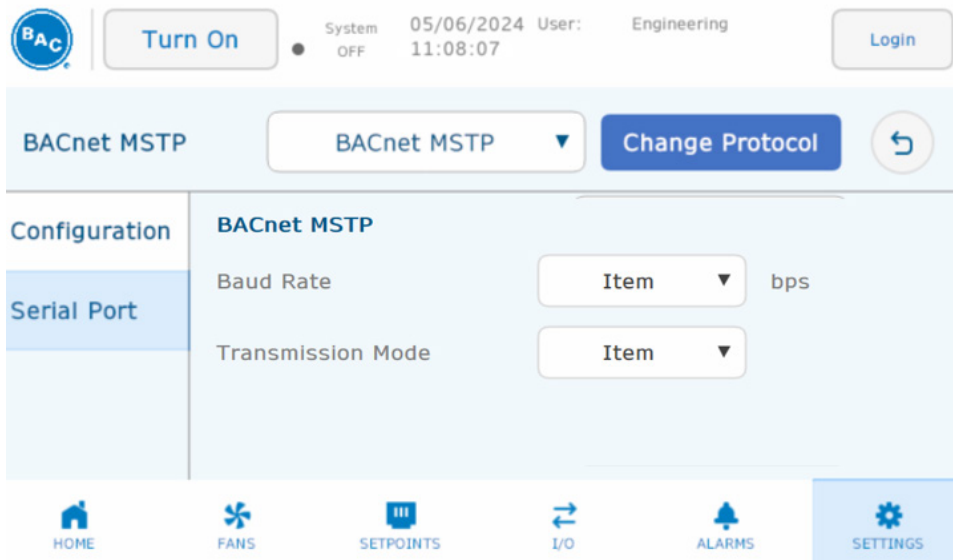

Figure 97. Settings Menu, BACnet MSTP Serial Port

Parameter	Description
Device Instance Number	Sets the correct value.
MAC Address	Sets the correct value.
Max Master	Sets the correct value.
Max Info Frames	Sets the correct value.
Timeout	Sets the correct value.
Baud Rate	Set the appropriate baud rate. Possible values (in kbps) are 9.6, 19.2, 38.4, 57.6 or 115.2.
Data Bits	The number of data bits is always 8.
Stop Bits	The number of stop bits always 1.
Parity	The parity is always odd.

Table 33. Settings Menu, BACnet MSTP Parameters

Modbus TCP Setup

Selecting BMS Protocol Modbus TCP from the setup menu shown in **Figure 93** and pressing the “Configure” button displays the Modbus TCP setup menu shown in **Figure 98** and **Figure 99** with parameters listed in **Table 34**.

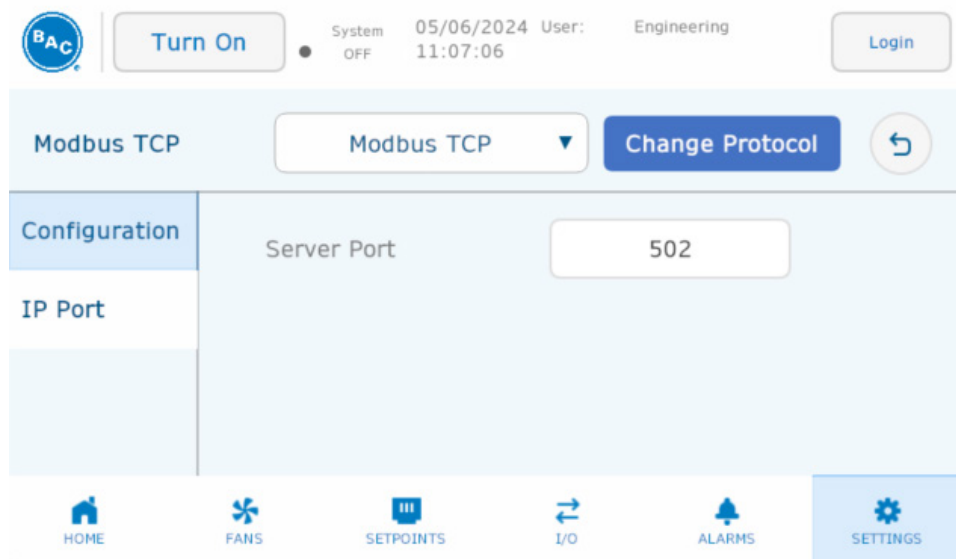

Figure 98. Settings Menu Modbus TCP Configuration

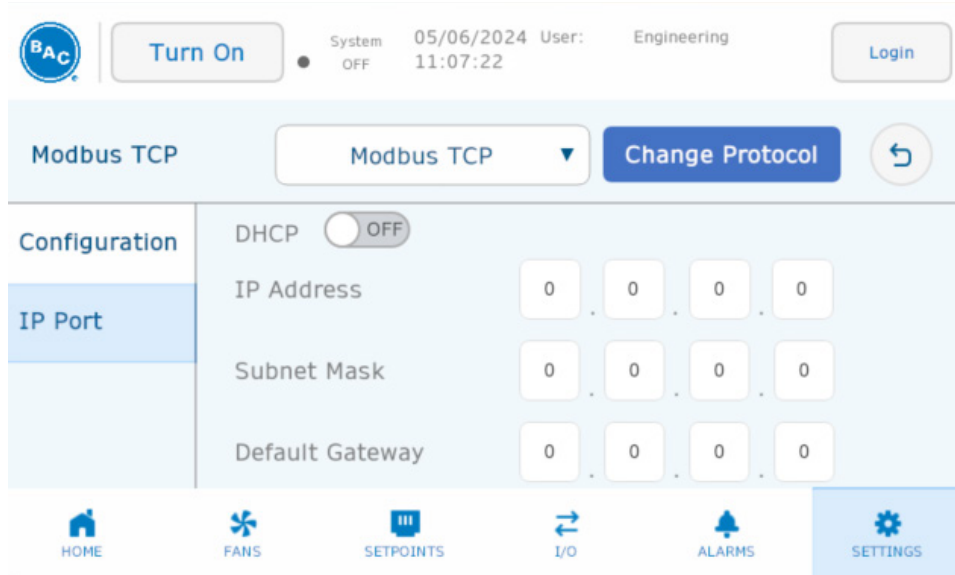

Figure 99. Settings Menu, Modbus TCP IP Port

Parameter	Description
Port Number	Sets the correct value.
DHCP	Enable to get address assigned automatically.
IP Address	Sets the correct value (in IPv4 format).
Subnet Mask	Sets the correct value (in IPv4 format).
Gateway	Sets the correct value (in IPv4 format).
DNS	Sets the correct value (in IPv4 format).

Table 34. Settings Menu, Modbus TCP Parameters

BACnet IP Setup

Selecting BMS Protocol BACnet IP from the setup menu shown in **Figure 93** and pressing the “Configure” button displays the BACnet IP setup menu shown in **Figure 100** and **Figure 101** with parameters listed in **Table 35**.

The screenshot shows the BACnet IP Configuration menu. At the top, there is a BACnet logo, a 'Turn On' button, system status (OFF), date (05/06/2024), time (11:08:43), user (Engineering), and a 'Login' button. Below this is a header for 'BACnet IP' with a dropdown menu set to 'BACnet IP' and a 'Change Protocol' button. The main configuration area has a left sidebar with 'Configuration' and 'IP Port' sections. Under 'Configuration', 'BACnet IP' is selected. Under 'IP Port', 'BACnet ID' is set to 123 and 'Port' is set to 123. At the bottom, there is a navigation bar with icons for HOME, FANS, SETPOINTS, I/O, ALARMS, and SETTINGS (which is highlighted).

Figure 100. Settings Menu, BACnet IP Configuration

The screenshot shows the BACnet IP Port configuration menu. It has the same top header as Figure 100. The 'BACnet IP' dropdown is still set to 'BACnet IP'. The left sidebar has 'Configuration' and 'IP Port' sections. Under 'Configuration', 'DHCP' is set to OFF. Under 'IP Port', 'IP Address', 'Subnet Mask', and 'Default Gateway' are all set to 0.0.0.0. The bottom navigation bar is the same as in Figure 100, with 'SETTINGS' highlighted.

Figure 101. Settings Menu, BACnet IP Port

Parameter	Description
Device Instance Number	Sets the correct value.
Network Number	Sets the correct value.
Port Number	Sets the correct value.
DHCP	Enable to get address assigned automatically.
IP Address	Sets the correct value (in IPv4 format).
Subnet Mask	Sets the correct value (in IPv4 format).
Gateway	Sets the correct value (in IPv4 format).
DNS	Sets the correct value (in IPv4 format).

Table 35. Settings Menu, BACnet IP Parameters

Software Version Menu

The Software Version menu is shown in **Figure 102** with parameters listed in **Table 36**.



Figure 102. Software Version

Parameter	Description
HMI Software Version	Indicates the current version
HMI Product Version	Indicates the HMI manufacturer's product version
HMI Buildtime Version	Indicates the HMI manufacturer's buildtime version.
HMI Runtime Version	Indicates the HMI manufacturer's runtime version.
PLC Software Version	Indicates the current version.
PLC Firmware Version	Indicates the current version.
PLC Application	Indicates the current version.
Hardware Configuration	Calibrate the touchscreen, set the HMIST6400's time and date, view SE hardware OS information, and upload new HMI software.

Table 36. Settings Menu, Software Version Parameters

Hardware Configuration Menu

The Hardware Configuration menu is shown in **Figure 103**, **Figure 104**, and **Figure 105**.

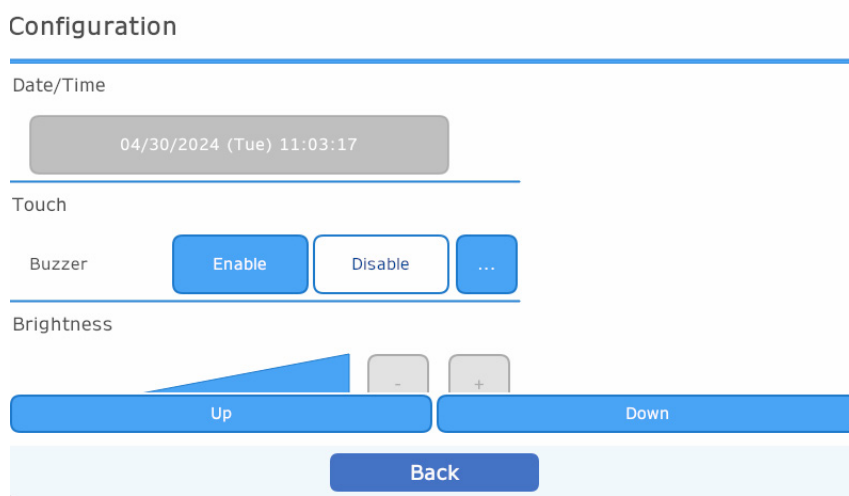

Figure 103 Hardware Configuration Parameters, Page 1 of 3

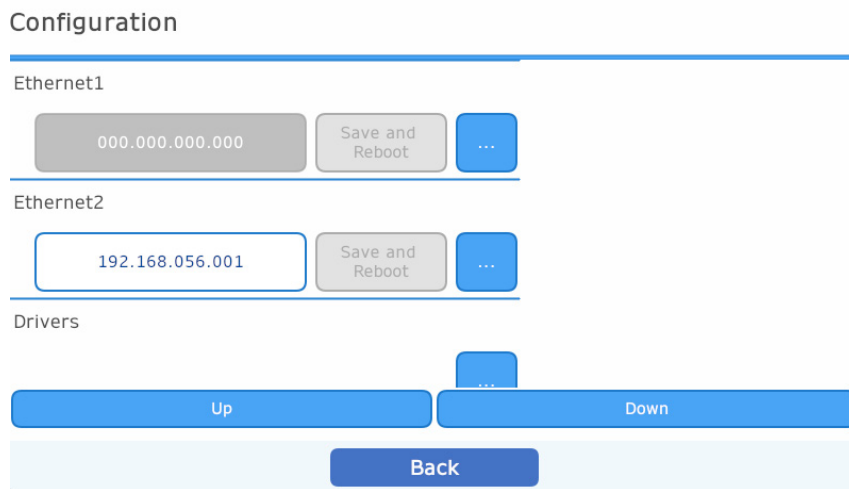

Figure 104 Hardware Configuration Parameters, Page 2 of 3



Figure 105 Hardware Configuration Parameters, Page 3 of 3

Technician Menu

The Technician menu is only displayed and accessible with Technician access level. Refer to **Table 10** Table 10. Access Levels and Passwords on **Page 52**. The Technician menu is shown in **Figure 106** with parameters listed in **Table 37**. Note that changing the Kp (proportional gain) parameters may result in a hunting phenomenon.

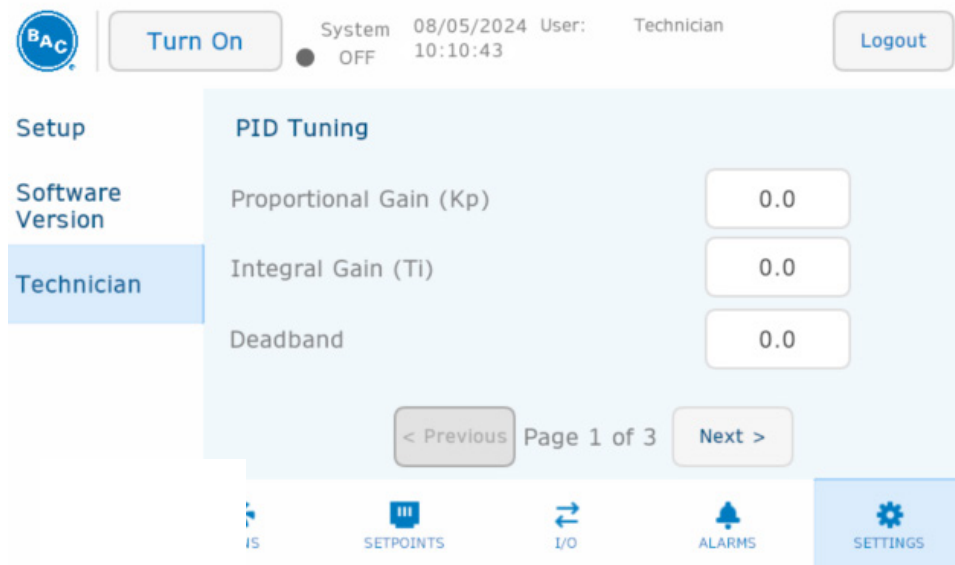

Figure 106. PID Tuning Menu, Technician Page 1 of 3

Parameter	Description
Kp	Set the value for the proportional band of the fan speed PI controller
Ti	Set the value for the integration time of the fan speed PI controller

Table 37. Setpoints Menu Technician Parameters

The Radar Calibration menu shown in **Figure 107** walks a technician through the process of calibrating the level sensor.

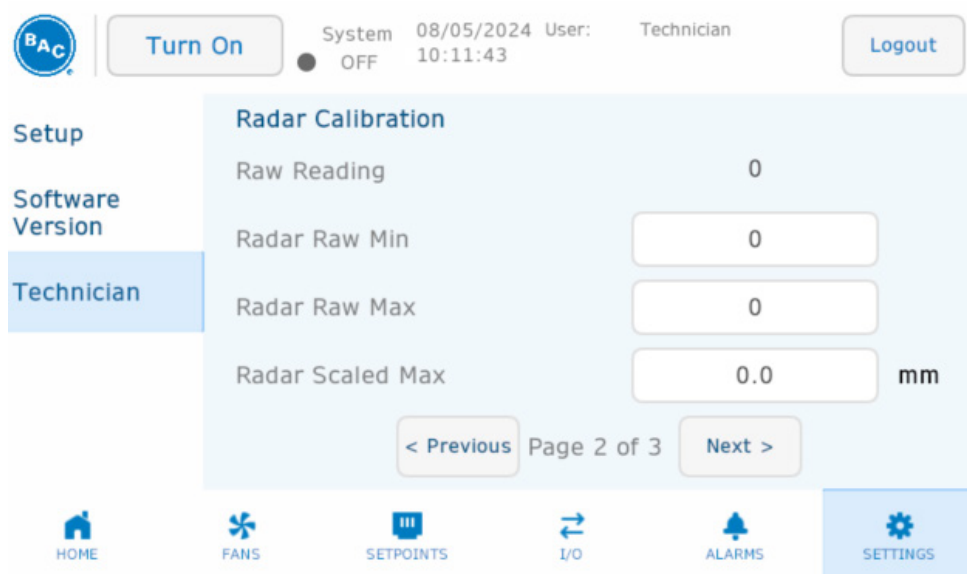

Figure 107. Radar Calibration Menu, Technician Page 2 of 3

	Description
Select Fan to Replace	Choose the address that needs to be programmed into the new fan.
Readdress New Fan	Set the correct address in the new fan.

Table 38. Technician Parameters

The Readdress Fan menu shown in **Figure 108** is to walk the technician through the process of addressing a newly installed fan.

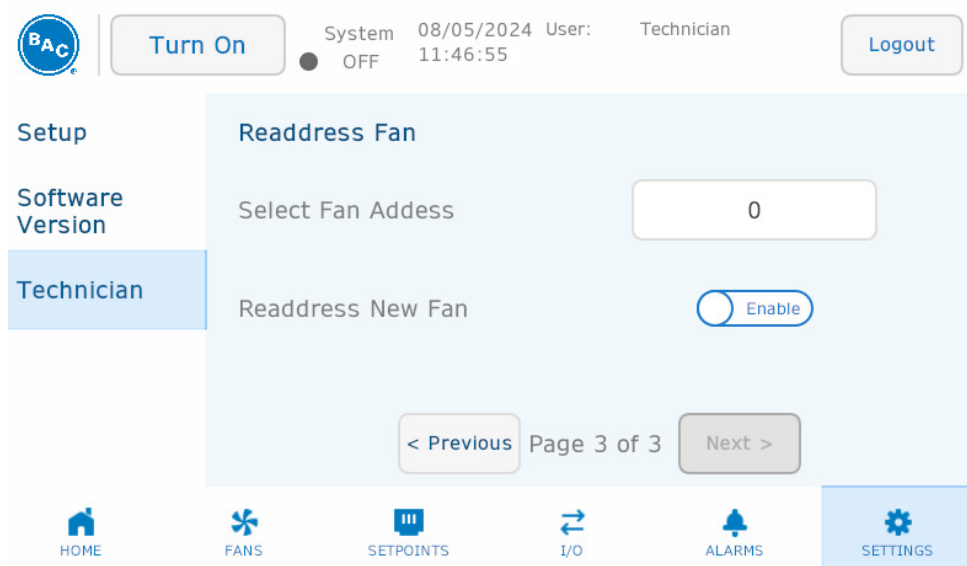

Figure 108: Readdress Fan, Technician Page 3 of 3

	Description
Raw Reading	Non-scaled input signal (read only)
Radar Raw Min	Non-scaled signal threshold to use as a reference for the 0 in/mm
Radar Raw Max	Non-scaled signal threshold to use as a reference for the Scaled Max in/mm
Radar Scaled Max	Threshold in in/mm to which the raw signal is scaled against

Table 39: Technician Parameters, Radar Calibration

Readdress New Fan

Replacement fans must be readdressed prior to unit operation. Refer to section **BAC Part Number 251299, Fan and Motor Removal & Installation on Page 35** or **BAC Part Number 251317 EC Fan and Motor Assembly Removal & Installation on Page 41** for instructions on removing and installing fans. Each fan needs to be assigned a unique address, starting with “1,2,3,...”. Replacement fans are pre-programmed with a default Modbus address of 247. Only one new fan can be readdressed at a time. If replacing multiple fans at a time, start with the fan closest to the control panel on the right side, Fan 2 in **Figure 109**. To address a newly installed fan:

1. Log in as Technician. Refer to **Table 10** Table 10. Access Levels and Passwords on **Page 52**.
2. Navigate to Settings menu, Technician Page 2 of 2 as shown in **Figure 106**.
3. Use the dropdown menu titled “Select Fan to Replace” to select the correct fan number. Refer to **Figure 109** to identify the correct fan number.
4. After selecting the fan that has been replaced, press the “Search” button. “Searching for Fans...” will be displayed to the left of the Search button.
5. When the new fan has been detected, a green checkmark icon will appear as shown in **Figure 110**. Press the “Readdress” button. Next press the “Readdress Fan” button to confirm readdress. The selected fan will be readdressed.

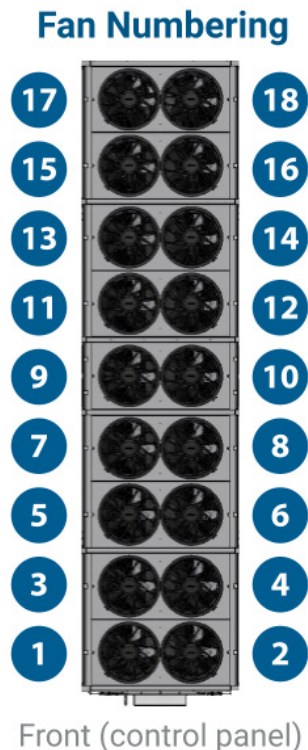

Figure 109. Fan Numbering Plan View

The screenshot displays the BACnet user interface. At the top left is the BAC logo. To its right is a 'Turn On' button and system status information: 'System OFF', '06/26/2024 14:04:33', and 'User: Engineering'. A 'Logout' button is in the top right. The left sidebar lists navigation options: 'Setup', 'Software Version', 'Technician' (highlighted), 'Manufacturing', and 'Engineering'. The main content area is titled 'Readdress Fan' and contains a 'Select Fan Address' input field with the value '0', and a 'Readdress New Fan' toggle switch currently set to 'Enable'. Below these are navigation buttons: '< Previous', 'Page 3 of 4', and 'Next >'. The bottom navigation bar features icons for 'HOME', 'FANS', 'SETPOINTS', 'I/O', 'ALARMS', and 'SETTINGS'.

Figure 110. Settings Menu, Technician Page 3 of 4 Readdress Fan

10. Unit Operation & Storage

TrilliumSeries™ Adiabatic Products are shipped fully wrapped. If the unit is going to remain in outdoor storage in excess of three months prior to installation, remove the stretch wrap and follow the prolonged outdoor storage recommendations listed in the TrilliumSeries™ Adiabatic Cooler – TRF Rigging & Assembly Instructions available at BaltimoreAircoil.com. If you start-up the unit within three months of delivery, follow the instructions below:

General

- Use appropriate lockout procedures. Do not perform any service on or near the unit without first ensuring the unit is de-energized.
- Verify the unit has been installed according to the TrilliumSeries™ Adiabatic Cooler – TRF Rigging & Assembly Instructions available at BaltimoreAircoil.com.

Corrosion Protection

BAC products are constructed of corrosion-resistant materials. Materials listed below are used in the equipment construction:

- **Galvanized Steel Components:** Inspect the galvanized steel components for blemishes or corrosion. Wire brush and recoat the affected areas with a cold galvanizing compound such as zinc rich compound (ZRC).
- **Thermosetting Hybrid Polymer Components:** Inspect the galvanized steel components protected with the thermosetting hybrid polymer for scratches, scrapes, or blemishes. Cosmetically touch up these areas with color matched paint.
- **Stainless Steel Components:** Inspect stainless steel components for signs of blemishes or corrosion. See section **Long Term Care of Stainless Steel** for cleaning and care instructions.

Long Term Care of Stainless Steel

When the percentage of chromium in steel exceeds 10.5%, it is called stainless steel. The chromium in the steel reacts with the oxygen in the air to form a chromium-oxide surface layer, also called the passivation layer that provides the corrosion resistance in stainless steel. BAC takes precautions to prevent cross-contamination, processing galvanized and stainless-steel parts separately. Also, stainless steel brushes are used to clean welds on stainless parts and care is taken to avoid scratching parts during processing. Organic cleaners are used to clean the finished product prior to shipping.

While stainless steel itself does not rust so long as the chromium-oxide surface layer is intact, it is not immune to contamination from its surroundings. Some common sources of surface contamination are:

- Dirt and soil
- Shop oil or grease that may carry other contaminants such as metal chips
- Machining or welding galvanized steel at the jobsite may cause debris to embed itself into the stainless steel

These contaminants can deposit on the surface and scratch the passivation layer or prevent it from re-forming. They can also get trapped underneath the passivation layer and reduce corrosion resistance.

Recommended Stainless Steel Cleaning Procedure



NOTE: Never use chloride or chlorine-based solvents such as bleach or muriatic (hydrochloric) acid to clean stainless steel. It is important to rinse the surface with warm water and wipe with a dry cloth after cleaning.

Stainless steel needs to be cleaned regularly to maintain the corrosion resistance as well as to maintain the overall aesthetics of the stainless steel. It is simple to clean most contaminants off the surface of stainless steel. Most dirt and soil can be cleaned with a clean cloth, warm water, and mild detergent. For persistent dirt, a little vinegar can be added in the cleaning water. It is important to always rinse the surface with warm water and wipe with a dry cloth after any cleaning, whether mild or aggressive.

- Fingerprints, mild stains, or grease spots can be cleaned using organic solvents such as acetone, methyl or ethyl alcohol, or mineral spirits. Stainless steel wipes or glass cleaners commonly available in stores may also be used.
- Occasionally the surface of stainless steel can get iron chips or shavings embedded in it from having galvanized steel machined or welded in the vicinity. The iron chips can start to rust, reducing the corrosion resistance of the stainless steel, and stain the surface giving the impression that the stainless steel is rusting. These types of contaminants require more aggressive cleaning. Mild abrasives such as Scotch-Brite™ products may be used where aesthetic considerations are not important followed by solvent cleaning with organic solvents as described above. It is important to rinse the surface with warm water and wipe with a dry cloth after cleaning.
- If the iron chips are not removed with the Scotch-Brite™ products, electro-chemical cleaning may be required. Contact your local BAC Representative for more information on commercially available equipment for electrochemical cleaning in the field.

Inspection

- Conduct external inspection of the equipment. Check for leaks, corrosion, and any structural damage.
- Conduct internal inspection of the equipment. Check for anything unusual such as structural or mechanical component damage.
- Inspect the pump(s), make-up valve(s), and drain valve. Remove any construction debris from inside the valves/sump.
- Thoroughly inspect the fan(s) for any mechanical or physical damage.
- Check that the float switches move freely.
- Inspect the water distribution system.

Cleaning

- Remove all dirt and debris from the fan guard(s).
- Inspect and clean the water distribution system.
- Clean all mechanical components, such as the fan and motor.

- Flush the sump to remove any accumulated dirt and debris.
- Remove, clean, and replace the sump strainers.
- Flush the piping supply water to the unit for at least 5 minutes to remove flux shavings and other construction debris.
- If necessary, clean the coil.
- If necessary, clean the adiabatic pre-cooler pads.
- After installation, remove any steel shavings from inside the unit. This will prevent shavings from rusting onto the surface of the thermosetting hybrid polymer, which may affect the coating's integrity over extended time.

Start-up

Control Panel

1. Verify the correct voltage to the control panel with a meter.
2. Before power has been provided to the unit, turn all breakers to the On position inside the control panel.
3. Close the control panel and ensure locks have been fully engaged by rotating 90 degrees on each bolt.
4. Remove any materials from the sump and ensure the sump access doors are closed and secured.
5. Turn on breaker or other power supply that supplies power to the unit.
6. Turn the control panel main disconnect switch to the On position.

Control Settings

7. Open the HMI cover and wait for the screen to show the home menu in **Figure 41**.
8. Navigate to Settings menu, Setup Page shown in **Figure 92** and **Figure 93**. Confirm correct Language, Date and Time are selected. If applicable, configure BMS protocol. Refer to **Table 40** for applicable BMS protocol setup page number.

BMS Protocol	Page Number
Modbus RTU	89
BACnet MSTP	90
Modbus TCP	91
BACnet IP	93

Table 40. BMS Protocol Setup Page Numbers

9. If unit is configured as a self-contained unit, navigate to Setpoints menu, Leaving Fluid Control as shown in **Figure 55**. Set appropriate Operating Mode, Leaving Fluid Temp Setpoint, Control Range, Adiabatic Switchpoint and Run Authorization Type. Refer to **Table 13** for parameter descriptions.
10. If unit is configured for a customer control signal, navigate to Setpoints menu, Customer Input Control as shown in **Figure 57**. Set appropriate Operating Mode, Signal Type, Adiabatic Switchpoint, and Run Authorization Type. Refer to **Table 13** for parameter descriptions.
11. Navigate to Fans menu shown in **Figure 46**. Press the unit icon on the left of the screen to enter the All Fans menu as shown in **Figure 47**. Set the appropriate Max Fan Speed and Emergency Fan Speed. Refer to **Table 12** for parameter descriptions.

12. Navigate to Alarms menu shown in **Figure 88**. Confirm there are no active alarms.

Component Operation

13. Press “Logout” in the upper right corner of the screen to navigate to the Login Screen as shown in **Figure 42**. Log in as Technician. Refer to **Table 10** Table 10. Access Levels and Passwords on **Page 53**.

14. Navigate to Fans menu, Manual as shown in **Figure 125**.

- Enter a Manual Setpoint of 100%.
- Use the radio button to turn Manual Mode to On.
- In the upper left corner of the screen press “Turn On System”.

15. Navigate to Fans menu as shown in **Figure 46**. Press on the picture of each fan and navigate to Analog Data menu to obtain data for each fan. Verify the fan status and actual speed of each fan.

16. Navigate to Fans menu, Manual as shown in **Figure 125**.

- Use the radio button to turn Manual Mode to Off.

17. Verify the make-up water connection is on and verify the pressure reducing valve is properly set to 45 psi (3 bar) by viewing the pressure setting indicator visible on both sides of the valve. Refer to Section Pressure Reducing Valve on **Page 21** for more details.

18. Navigate to I/O menu, Manual Page 2 of 2 as shown in **Figure 87**.

- Use the radio button to turn drain valve manual mode to On.
- Press the blue button to close the drain valve.

19. Navigate to I/O menu, Page 1 of 2 as shown in **Figure 86**.

- Use the radio buttons to turn make-up valve 1 and 2 manual mode to On.
- Press the blue button to open make-up valve 1 and 2.
- Wait for water to fill the sump. Before proceeding, visually confirm the water level has reached the high float switch shown in **Figure 16**.
- Use the radio buttons to turn make-up valve 1 and 2 manual mode to Off.
- Use the radio buttons to turn pump 1 and 2 manual mode to On.
- Press the blue button to turn pump 1 and 2 On.
- Verify adiabatic pre-cooler pads are being wetted on both sides of the unit.
- Press the blue button to turn pump 1 and 2 Off.
- Use the radio buttons to turn pump 1 and 2 manual mode to Off.

20. Navigate to I/O menu, Manual Page 2 of 2 as shown in **Figure 87**.

- Press the blue button to open the drain valve.
- Use the radio button to turn drain valve manual mode to Off.

21. Press “Logout” in the upper right corner to log out as Technician.

Extended Shutdown

Perform the following services whenever the unit is shutdown in excess of three days:



NOTE: Do not use steam, high-pressure water, or high-pressure air to clean any component.

- Disconnect, lock-out, and tag-out the unit.
- Close the shut-off valve in the make-up water line (supplied by others) and drain the sump and all exposed water piping. Heat trace all exposed make-up water lines if the water cannot be shut off and external piping cannot be drained.
- To minimize the risk of biological contamination during shutdown, it is recommended the entire system be drained.
- Coils must be empty and closed off. For extended shutdown periods coils should be charged with nitrogen at 15 psig in the field and capped by adding a welded cap. Upon start-up, the coil connections will require cutting.
- Insert desiccant bags into the control panel to absorb moisture. Seal the control panel for storage
- Clean all debris, such as leaves and dirt, from the interior and exterior of the unit.
- Clean and flush the water distribution system and sump.
- Leave sump drain valve open so rain and melting snow will drain from the unit.
- Clean the sump strainer and re-install.
- Cover the fan discharge to keep out dirt and debris.
- Inspect the protective finish on the unit. Clean and refinish as required.
- Start-up and operate fan motors at full speed for at least three hours once a month to move the bearings and allow any condensate that may have ingressed to evaporate

11. Alarms & Troubleshooting

Unit Alarms & Troubleshooting

Unit alarms and troubleshooting recommendations are listed in **Table 43** through **Table 53**. Unit alarm codes are listed in **Table 41** and **Table 42**.

Unit Alarm Word 1	
Bit	Alarm Description
0	Emergency Stop Active
1	General Unit Alarm
2	General Fan Alarm
3	Low LFT Alarm
4	High LFT Alarm
5	Leaving Fluid Temp Sensor Fail
6	Outside Air Temp Sensor Fail
7	Reserved
8	Reserved
9	Reserved
10	Fan(s) Communication Offline
11	Reserved
12	Reserved
13	Low Setpoint Current
14	Reserved
15	Reserved

Table 41: Unit Alarms, Page 1 of 2

Unit Alarm Word 2	
Bit	Alarm Description
0	Basin Water Level
1	Level Sensor Fail
2	Pump Failure
3	Pump Lockout Alarm
4	Drain Valve Alarm
5	Make Up Alarm
6	Reserved
7	Reserved
8	Reserved
9	Reserved
10-15	Reserved

Table 42: Unit Alarms, Page 2 of 2

Parameter	Condition
Trigger Criteria	The unit will issue the alarm when all the following are true: <ul style="list-style-type: none"> • Pump X Contact is On for 10 consecutive seconds • Pump X Current Switch is False for 3 consecutive seconds
Release Criteria	The unit will release the alarm when any of the following are true: <ul style="list-style-type: none"> • Pump X Contact is Off • Pump X Contact is On AND Pump X Current Switch is True
Troubleshooting	<ul style="list-style-type: none"> • Check Pump X and wiring • Check Pump X Current Switch and wiring
General Alarm DO	True
Effect	If this alarm occurs 3 times, Pump X will be locked out and the alarm must be cleared via the HMI.

Table 43. Pump X No Current / Failure Alarm

Parameter	Condition
Trigger Criteria	The unit will issue the alarm when the following is true: <ul style="list-style-type: none"> • 3 Pump X No Current Alarms have occurred
Release Criteria	The unit will release the alarm when the following is true: <ul style="list-style-type: none"> • Pump X Lockout is cleared
Troubleshooting	<ul style="list-style-type: none"> • Check Pump X and wiring • Check Pump X Current Switch and wiring
General Alarm DO	True
Effect	Pump X will be locked out from starting.

Table 44. Pump X Lock Out Alarm

Parameter	Condition
Trigger Criteria	The unit will issue the alarm when any of the following are true: <ul style="list-style-type: none"> • Control Type = LFT Ctrl AND Fluid Type = Water AND Leaving Fluid Temperature ≤ 10 °C for 3 consecutive seconds • Control Type = LFT Ctrl AND Fluid Type = Glycol AND Leaving Fluid Temperature ≤ 7.2 °C for 3 consecutive seconds
Release Criteria	The unit will release the alarm when any of the following are true: <ul style="list-style-type: none"> • Control Type = LFT Ctrl AND Fluid Type = Water AND Leaving Fluid Temperature > 13 °C for 3 consecutive seconds • Control Type = LFT Ctrl AND Fluid Type = Glycol AND Leaving Fluid Temperature > 10.2 °C for 3 consecutive seconds • Control Type \neq LFT Ctrl
Troubleshooting	<ul style="list-style-type: none"> • Check Leaving Fluid Temperature sensor installation • Check Leaving Fluid Temperature sensor and wiring
General Alarm DO	True
Effect	Emergency Flag = True

Table 45. Low Leaving Fluid Temperature Alarm

Parameter	Condition
Trigger Criteria	<p>The unit will issue the alarm when all the following are true:</p> <p>Low Level Alarm If Basin Type = Recirculation</p> <ul style="list-style-type: none"> • Water Level is below Low Level for 5 consecutive minutes • Drain Valve = Closed • Makeup Valve = Open <p>High Level Alarm If Basin Type = Recirculation</p> <ul style="list-style-type: none"> • Water Level is above Overflow Level for 3 consecutive minutes
Release Criteria	<p>The unit will release the alarm when the following is true:</p> <p>Low Level Alarm</p> <ul style="list-style-type: none"> • Water Level is at or above Low Level for 3 consecutive seconds <p>-OR-</p> <ul style="list-style-type: none"> • Basin Type is not Recirculation <p>High Level</p> <ul style="list-style-type: none"> • Water Level is below Overflow Level for 3 consecutive seconds <p>-OR-</p> <ul style="list-style-type: none"> • Basin Type is not Recirculation
Troubleshooting	<ul style="list-style-type: none"> • Check Level Sensor and wiring • Check Drain Valve and wiring
General Alarm DO	True
Effect	N/A

Table 46. Basin Water Alarm

Parameter	Condition
Trigger Criteria	<p>The unit will issue the alarm when all the following are true:</p> <ul style="list-style-type: none"> • Drain Valve = Open • Basin Type = Recirculation • Basin has been above Low level Limit for 35 minutes
Release Criteria	<p>The unit will release the alarm when the following is true:</p> <ul style="list-style-type: none"> • Water Level is below Low-Level limit for 3 consecutive seconds • Basin Type is Once Through
Troubleshooting	<ul style="list-style-type: none"> • Check Level Sensor and wiring • Check Drain Valve and wiring
General Alarm DO	True
Effect	N/A

Table 47. Drain Valve Alarm

Parameter	Condition
Trigger Criteria	<p>The unit will issue the alarm when all the following are true:</p> <p>If Basin Type = Recirculation</p> <ul style="list-style-type: none"> • Make Up Valve X = Open -OR- • Drain Valve = Closed • Basin is at Pump Cutout Level for 10 minutes <p>If Basin Type = Once Through</p> <ul style="list-style-type: none"> • Make Up X = Open for 5 minutes • Precooler Temperature sensors are enabled • Precooler X Temp > Outside Ambient Temperature – 1°C
Release Criteria	<p>The unit will release the alarm when the following is true:</p> <p>If Basin Type = Recirculation:</p> <ul style="list-style-type: none"> • Basin is at or above Low-Level for 3 consecutive seconds • Drain Valve is Open • Make Up X is Closed <p>If Basin Type = Once Through:</p> <ul style="list-style-type: none"> • Precooler Temp < Outside Ambient Temperature – 1°C -OR- • Precooler sensor is disabled -OR- • Make Up X is Closed
Troubleshooting	<ul style="list-style-type: none"> • Check Make Up Valve X • Check Level Sensor and wiring • Check Drain Valve and wiring
General Alarm DO	True
Effect	N/A

Table 48. Make Up X Alarm

Parameter	Condition
Trigger Criteria	<p>The unit will issue the alarm when all the following are true:</p> <ul style="list-style-type: none"> • Control Type = LFT Ctrl • Leaving Fluid Temperature > 90 °C OR • Leaving Fluid Temperature < -50 °C OR
Release Criteria	<p>The unit will release the alarm when any of the following are true:</p> <ul style="list-style-type: none"> • Control Type is not LFT Ctrl • Leaving Fluid Temperature ≤ 87 °C • Leaving Fluid Temperature ≥ -47 °C
Troubleshooting	<ul style="list-style-type: none"> • Check Leaving Fluid Temperature sensor installation • Check Leaving Fluid Temperature sensor and wiring
General Alarm DO	True
Effect	Emergency Flag = True

Table 49. Leaving Fluid Temperature Sensor Alarm

Parameter	Condition
Trigger Criteria	The unit will issue the alarm when any of the following are true: <ul style="list-style-type: none"> • Outside Air Temperature < -30 °C for 3 consecutive seconds • Outside Air Temperature > 60 °C for 3 consecutive seconds
Release Criteria	The unit will release the alarm when any of the following are true: <ul style="list-style-type: none"> • Outside Air Temperature ≥ -27 °C for 3 consecutive seconds AND Outside Air Temperature ≤ 57 °C for 3 consecutive seconds
Troubleshooting	<ul style="list-style-type: none"> • Check Outside Air Temperature sensor installation • Check Outside Air Temperature sensor and wiring
General Alarm DO	True
Effect	Disable Water = True

Table 50. Outside Air Temperature Sensor Alarm

Parameter	Condition
Trigger Criteria	The unit will issue the alarm when the following is true: <ul style="list-style-type: none"> • All fans time out Modbus communications
Release Criteria	The unit will release the alarm when the following is true: <ul style="list-style-type: none"> • Any fan regains Modbus communications
Troubleshooting	<ul style="list-style-type: none"> • Check E-Stop button • Check Fan Modbus wiring between control panel and fan 1
General Alarm DO	True
Effect	Disable Water = True

Table 51. All Fans Offline/E-Stop Alarm

Parameter	Condition
Trigger Criteria	The unit will issue the alarm when any of the following are true: <ul style="list-style-type: none"> • Level < -10 inches -OR- • Level > 10 inches
Release Criteria	The unit will release the alarm the following is true: <ul style="list-style-type: none"> • Level > 0 inches -OR- • Level < 8 inches
Troubleshooting	<ul style="list-style-type: none"> • Check Level Sensor • Check Level Sensor wiring
General Alarm DO	True
Effect	N/A

Table 52. Level Sensor Fail Alarm

Parameter	Condition
Trigger Criteria	The unit will issue the alarm when all the following are true: <ul style="list-style-type: none"> • Control Type = LFT Control • LFT > 85.0 °C
Release Criteria	The unit will release the alarm when any of the following are true: <ul style="list-style-type: none"> • Control Type is not LFT Control • LFT ≤ 82 °C
Troubleshooting	<ul style="list-style-type: none"> • Check fluid temperatures elsewhere in the loop • Check leaving fluid temperature sensor
General Alarm DO	True
Effect	N/A

Table 53. High Leaving Fluid Temperature Alarm

Fan Alarms & Troubleshooting

Fan alarms and troubleshooting recommendations are listed in **Table 54** through **Table 64**. Fan alarm codes are listed in **Table 67**.

Parameter	Condition
Trigger Criteria	The unit will issue the alarm when all the following are true: <ul style="list-style-type: none"> • Number of Fans \geq Fan X • Fan X times out Modbus communications
Release Criteria	The unit will release the alarm when any of the following are true: <ul style="list-style-type: none"> • Number of Fans $<$ Fan X • Fan X regains Modbus communications
Troubleshooting	Check Fan X's circuit breaker in control panel
General Alarm DO	True
Effect	N/A

Table 54. Fan X Offline Alarm

Parameter	Condition
Trigger Criteria	The unit will issue the alarm when all the following are true: <ul style="list-style-type: none"> • Number of Fans \geq Fan X • Fan X Modbus Address D011 MSB bit 5 = 1
Release Criteria	The unit will release the alarm when any of the following are true: <ul style="list-style-type: none"> • Number of Fans $<$ Fan X • Fan X Modbus Address D011 MSB bit 5 = 0
Troubleshooting	Check power supply to unit
General Alarm DO	True
Effect	N/A

Table 55. Fan X DC-link Undervoltage Alarm

Parameter	Condition
Trigger Criteria	The unit will issue the alarm when all the following are true: <ul style="list-style-type: none"> • Number of Fans \geq Fan X • Fan X Modbus Address D011 MSB bit 3 = 1
Release Criteria	The unit will release the alarm when any of the following are true: <ul style="list-style-type: none"> • Number of Fans $<$ Fan X • Fan X Modbus Address D011 MSB bit 3 = 0
Troubleshooting	Contact your BAC Representative for support
General Alarm DO	True
Effect	N/A

Table 56. Fan X Position Sensor Calibration Error Alarm

Parameter	Condition
Trigger Criteria	The unit will issue the alarm when all the following are true: <ul style="list-style-type: none"> • Number of Fans \geq Fan X • Fan X Modbus Address D011 MSB bit 1 = 1
Release Criteria	The unit will release the alarm when any of the following are true: <ul style="list-style-type: none"> • Number of Fans $<$ Fan X • Fan X Modbus Address D011 MSB bit 1 = 0
Troubleshooting	Contact your BAC Representative for support
General Alarm DO	True
Effect	N/A

Table 57. Fan X Speed Limit Exceeded Alarm

Parameter	Condition
Trigger Criteria	The unit will issue the alarm when all the following are true: <ul style="list-style-type: none"> • Number of Fans \geq Fan X • Fan X Modbus Address D011 LSB bit 8 = 1
Release Criteria	The unit will release the alarm when any of the following are true: <ul style="list-style-type: none"> • Number of Fans $<$ Fan X • Fan X Modbus Address D011 LSB bit 8 = 0
Troubleshooting	Inspect Fan X and ensure there are no obstructions
General Alarm DO	True
Effect	N/A

Table 58. Fan X Motor Blocked Alarm

Parameter	Condition
Trigger Criteria	The unit will issue the alarm when all the following are true: <ul style="list-style-type: none"> • Number of Fans \geq Fan X • Fan X Modbus Address D011 LSB bit 7 = 1
Release Criteria	The unit will release the alarm when any of the following are true: <ul style="list-style-type: none"> • Number of Fans $<$ Fan X • Fan X Modbus Address D011 LSB bit 7 = 0
Troubleshooting	Contact your BAC Representative for support
General Alarm DO	True
Effect	N/A

Table 59. Fan X Motor Hall Sensor Error Alarm

Parameter	Condition
Trigger Criteria	The unit will issue the alarm when all the following are true: <ul style="list-style-type: none"> • Number of Fans \geq Fan X • Fan X Modbus Address D011 LSB bit 6 = 1
Release Criteria	The unit will release the alarm when any of the following are true: <ul style="list-style-type: none"> • Number of Fans $<$ Fan X • Fan X Modbus Address D011 LSB bit 6 = 0
Troubleshooting	Contact your BAC Representative for support
General Alarm DO	True
Effect	N/A

Table 60. Fan X Motor Overheating Alarm

Parameter	Condition
Trigger Criteria	The unit will issue the alarm when all the following are true: <ul style="list-style-type: none"> • Number of Fans \geq Fan X • Fan X Modbus Address D011 LSB bit 5 = 1
Release Criteria	The unit will release the alarm when any of the following are true: <ul style="list-style-type: none"> • Number of Fans $<$ Fan X • Fan X Modbus Address D011 LSB bit 5 = 0
Troubleshooting	Contact your BAC Representative for support
General Alarm DO	True
Effect	N/A

Table 61. Fan X Fan Bad (General Error) Alarm

Parameter	Condition
Trigger Criteria	The unit will issue the alarm when all the following are true: <ul style="list-style-type: none"> • Number of Fans \geq Fan X • Fan X Modbus Address D011 LSB bit 4 = 1
Release Criteria	The unit will release the alarm when any of the following are true: <ul style="list-style-type: none"> • Number of Fans < Fan X • Fan X Modbus Address D011 LSB bit 4 = 0
Troubleshooting	<ul style="list-style-type: none"> • Check Fan X communication wiring • Check Fan X communication shielding
General Alarm DO	True
Effect	N/A

Table 62. Fan X Communication Error Alarm

Parameter	Condition
Trigger Criteria	The unit will issue the alarm when all the following are true: <ul style="list-style-type: none"> • Number of Fans \geq Fan X • Fan X Modbus Address D011 LSB bit 3 = 1
Release Criteria	The unit will release the alarm when any of the following are true: <ul style="list-style-type: none"> • Number of Fans < Fan X • Fan X Modbus Address D011 LSB bit 3 = 0
Troubleshooting	Contact your BAC Representative for support
General Alarm DO	True
Effect	N/A

Table 63. Fan X Output Stage Overheating Alarm

Parameter	Condition
Trigger Criteria	The unit will issue the alarm when all the following are true: <ul style="list-style-type: none"> • Number of Fans \geq Fan X • Fan X Modbus Address D011 LSB bit 1 = 1
Release Criteria	The unit will release the alarm when any of the following are true: <ul style="list-style-type: none"> • Number of Fans < Fan X • Fan X Modbus Address D011 LSB bit 1 = 0
Troubleshooting	<ul style="list-style-type: none"> • Check power supply to unit • Contact BAC Support
General Alarm DO	True
Effect	N/A

Table 64. Fan X Phase Failure Alarm

Unit Alarm Codes

Unit Alarm codes listed **Table 65** and **Table 66** in are enumerations porting a number code to a specific alarm. These codes are used in the BMS communications to effectively communicate active alarms. Alarms not listed explicitly will trigger the General Unit Alarm.

Unit Alarm Word 1	
Bit	Alarm Description
0	Emergency Stop Active
1	General Unit Alarm
2	General Fan Alarm
3	Low LFT Alarm
4	High LFT Alarm
5	Leaving Fluid Temp Sensor Fail
6	Outside Air Temp Sensor Fail
7	Reserved
8	Reserved
9	Reserved
10	Fan(s) Communication Offline
11	Reserved
12	Reserved
13	Low Setpoint Current
14	Reserved
15	Reserved

Table 65: Unit Alarm Codes, Page 1 of 2

Unit Alarm Word 2	
Bit	Alarm Description
0	Basin Water Level
1	Level Sensor Fail
2	Pump Failure
3	Pump Lockout Alarm
4	Drain Valve Alarm
5	Make Up Alarm
6	Reserved
7	Reserved
8	Reserved
9	Reserved
10	Reserved
11	Reserved
12	Reserved
13	Reserved
14	Reserved
15	Reserved

Table 66. Unit Alarm Codes, Page 2 of 2

Fan Alarm Codes

Fan Alarm codes listed in **Table 67** are enumerations porting a number code to a specific alarm. These codes are used in the BMS communications to effectively communicate active alarms. Alarms not explicitly listed will trigger the General Fan Alarm.

Fan Alarm Word	
Bit	Fan Alarm
0	General Fan X Alarm
1	Fan X Communication to PLC Offline
2	Reserved
3	Reserved
4	Fan DC Link Overvoltage
5	Fan DC Link Undervoltage
6	Output Phase Loss
7	Input Phase Loss
8	Output Overcurrent
9	Fan Communication Fault
10-15	Reserved

Table 67. Fan Alarm Codes

12. BMS Communication

BACnet IP & Modbus TCP

BACnet IP and Modbus TCP shall be connected via the RJ45 bulkhead at the bottom of the control panel.

Modbus RTU Communications, Points List

Table 68. Modbus RTU Communications, Points List, Unit Control

Variable	Description	Default	R/W	Data Type	Modbus RTU Registers
RunType	Unit's Run Authorization Type 1 = HMI (only) 2 = Digital Input (AND HMI) 3 = BMS (AND HMI)	1	R/W	INT	416500
UnitSelection	Selects the unit of parameters indicating power, distance and temperature. 0 = Metric units (°C, mm) 1 = Imperial Units (°F, in)	1	R/W	BOOL	416501
FanClsetpoint	Customer Input BMS Fan Speed Setpoint	-	R/W	REAL	412252
LFTControlRange [0-10°]	Leaving Fluid Temperature Control Deadband	0.2	R/W	REAL	420208
LFTSetpointProportionalGain [0-300]	Leaving Fluid Temperature Control Proportional Gain	10.0	R/W	REAL	416554
LFTSetpointIntegralTime [0-6000]	Leaving Fluid Temperature Control Integral Time (Ti)	100.0	R/W	REAL	416556
BMSRunEnable	BMS Run Enable 0 = Off 1 = On	0	R/W	BOOL	416505
ControlState	Unit State 0 = Undefined 1 = Off 2 = Manual 3 = Dry 4 = Single 5 = Dual 6 = Coil Clean 7 = Wet Coil Clean 8 = Pad Clean 9 = Drain Dry 10 = Emergency	-	R	INT	412002

Table 68. Modbus RTU Communications, Points List, Unit Control					
Variable	Description	Default	R/W	Data Type	Modbus RTU Registers
DigitalRunEnableStatus	Digital Input Run Enable Status 0 = Off 1 = On	-	R	BOOL	412100
EmergencyStopStatus	Emergency Stop Status 0 = Not pressed 1 = Pressed	-	R	BOOL	412101
RunIndicatorStatus	Run Indicator Digital Output Status 0 = Not Running 1 = Running	-	R	BOOL	412150
GeneralAlarmStatus	General Alarm Digital Output Status 0 = No active alarms 1 = At least 1 alarm active	-	R	BOOL	412151
LeavingFluidTemperature	Leaving Fluid Temperature in °C/°F	-	R	REAL	412200
LeavingFluidTemperatureSp	Leaving Fluid Temperature Setpoint in °C/ °F	-	R	REAL	416550
OutsideAirTemperature	Outside Air Temperature in °C/°F	-	R	REAL	412204
AdiabaticSwitchpoint	Adiabatic Switchpoint n °C/°F	-	R/W	REAL	415905
ClockSeconds	Seconds [0-59]	-	R	USINT	48736
ClockMinutes	Minutes [0-59]	-	R	USINT	48737
ClockHours	Hours [0-23]	-	R	USINT	48738
ClockDayWeek	Day of the week [0 = Sunday, 6 = Saturday]	-	R	USINT	48739
ClockDayMonth	Day of the Month [1 - 31]	-	R	USINT	48740
ClockMonth	Month [1 - 12]	-	R	USINT	48741
ClockYear	Year [10-99]	-	R	USINT	48742

Table 68. Modbus RTU Communications, Points List, Unit Control

Table 69. Modbus RTU Communications, Points List, Fans

Variable	Description	R/W	Data Type	Modbus RTU Registers	Bit
AllFansCommandPct	Command % (in accordance with max rpm) sent to all fans	R	REAL	411000	
AllFansCommandRpm	Command RPM sent to all fans	R	INT	411002	
AverageFanSpeedPct	Average all fans speed in % of max rpm	R	REAL	411003	
AverageFanSpeedRpm	Average all fans speed in RPM	R	INT	411005	
AverageFanPower	Average all fans power in kW/hp	R	REAL	411006	
AverageFanCurrent	Average all fans current in A	R	REAL	411008	
Fan1CommandSpeedPct	Command % (of max rpm) sent to Fan 1	R	REAL	411010	
Fan1CommandSpeedRpm	Command rpm sent to Fan1	R	INT	411012	
Fan1ActualSpeedPct	Fan 1 Actual Speed in % of max rpm	R	REAL	411013	
Fan1ActualSpeedRpm	Fan 1 Actual Speed in RPM	R	INT	411015	
Fan1Communications	Fan 1 VFD Communications to PLC 0 = Offline 1 = Online	R	BOOL	411017	0
Fan1Spinning	0 = Fan is not spinning 1 = Fan is spinning	R	BOOL	411017	1
Fan1ActualDirection	0 = Fan 1 is in the forward direction 1 = Fan 1 is in the reverse direction	R	BOOL	411017	3
Fan1FaultStatus	0 = Fan 1 does not indicate a fault 1 = Fan 1 indicates a fault	R	BOOL	411017	4
Fan2CommandSpeedPct	Command % (of max rpm) sent to Fan 2	R	REAL	411020	
Fan2CommandSpeedRpm	Command RPM sent to Fan2	R	INT	411022	
Fan2ActualSpeedPct	Fan 2 Actual Speed in % of max rpm	R	REAL	411023	
Fan2ActualSpeedRpm	Fan 2 Actual Speed in RPM	R	INT	411025	
Fan2Communications	Fan 2 Communications to PLC 0 = Offline 1 = Online	R	BOOL	411027	0
Fan2Spinning	0 = Fan is not spinning 1 = Fan is spinning	R	BOOL	411027	1

Table 69. Modbus RTU Communications, Points List, Fans

Variable	Description	R/W	Data Type	Modbus RTU Registers	Bit
Fan2ActualDirection	0 = Fan 2 is in the forward direction 1 = Fan 2 is in the reverse direction	R	BOOL	411027	3
Fan2FaultStatus	0 = Fan 2 does not indicate a fault 1 = Fan 2 indicates a fault	R	BOOL	411027	4
Fan3CommandSpeedPct	Command % (of max rpm) sent to Fan 3	R	REAL	411030	
Fan3CommandSpeedRpm	Command RPM sent to Fan3	R	INT	411032	
Fan3ActualSpeedPct	Fan 3 Actual Speed in % of max rpm	R	REAL	411033	
Fan3ActualSpeedRpm	Fan 3 Actual Speed in RPM	R	INT	411035	
Fan3Communications	Fan 3 Communications to PLC 0 = Offline 1 = Online	R	BOOL	411037	0
Fan3Spinning	0 = Fan is not spinning 1 = Fan is spinning	R	BOOL	411037	1
Fan3ActualDirection	0 = Fan 3 is in the forward direction 1 = Fan 3 is in the reverse direction	R	BOOL	411037	3
Fan3FaultStatus	0 = Fan 3 does not indicate a fault 1 = Fan 3 indicates a fault	R	BOOL	411037	4
Fan4CommandSpeedPct	Command % (of max rpm) sent to Fan 4	R	REAL	411040	
Fan4CommandSpeedRpm	Command RPM sent to Fan4	R	INT	411042	
Fan4ActualSpeedPct	Fan 4 Actual Speed in % of max rpm	R	REAL	411043	
Fan4ActualSpeedRpm	Fan 4 Actual Speed in RPM	R	INT	411045	
Fan4Communications	Fan 4 Communications to PLC 0 = Offline 1 = Online	R	BOOL	411047	0
Fan4Spinning	0 = Fan is not spinning 1 = Fan is spinning	R	BOOL	411047	1
Fan4ActualDirection	0 = Fan 4 is in the forward direction 1 = Fan 4 is in the reverse direction	R	BOOL	411047	3
Fan4FaultStatus	0 = Fan 4 does not indicate a fault 1 = Fan 4 indicates a	R	BOOL	411047	4

Table 69. Modbus RTU Communications, Points List, Fans

Variable	Description	R/W	Data Type	Modbus RTU Registers	Bit
	fault				
Fan5CommandSpeedPct	Command % (of max rpm) sent to Fan 5	R	REAL	411050	
Fan5CommandSpeedRpm	Command RPM sent to Fan5	R	INT	411052	
Fan5ActualSpeedPct	Fan 5 Actual Speed in % of max rpm	R	REAL	411053	
Fan5ActualSpeedRpm	Fan 5 Actual Speed in RPM	R	INT	411055	
Fan5Communications	Fan 5 Communications to PLC 0 = Offline 1 = Online	R	BOOL	411057	0
Fan5Spinning	0 = Fan is not spinning 1 = Fan is spinning	R	BOOL	411057	1
Fan5ActualDirection	0 = Fan 5 is in the forward direction 1 = Fan 5 is in the reverse direction	R	BOOL	411057	3
Fan5FaultStatus	0 = Fan 5 does not indicate a fault 1 = Fan 5 indicates a fault	R	BOOL	411057	4
Fan6CommandSpeedPct	Command % (of max rpm) sent to Fan 6	R	REAL	411060	
Fan6CommandSpeedRpm	Command RPM sent to Fan6	R	INT	411062	
Fan6ActualSpeedPct	Fan 6 Actual Speed in % of max rpm	R	REAL	411063	
Fan6ActualSpeedRpm	Fan 6 Actual Speed in RPM	R	INT	411065	
Fan6Communications	Fan 6 Communications to PLC 0 = Offline 1 = Online	R	BOOL	411067	0
Fan6Spinning	0 = Fan is not spinning 1 = Fan is spinning	R	BOOL	411067	1
Fan6ActualDirection	0 = Fan 6 is in the forward direction 1 = Fan 6 is in the reverse direction	R	BOOL	411067	3
Fan6FaultStatus	0 = Fan 6 does not indicate a fault 1 = Fan 6 indicates a fault	R	BOOL	411067	4
Fan7CommandSpeedPct	Command % (of max rpm) sent to Fan 7	R	REAL	411070	
Fan7CommandSpeedRpm	Command RPM sent to Fan7	R	INT	411072	

Table 69. Modbus RTU Communications, Points List, Fans

Variable	Description	R/W	Data Type	Modbus RTU Registers	Bit
Fan7ActualSpeedPct	Fan 7 Actual Speed in % of max rpm	R	REAL	411073	
Fan7ActualSpeedRpm	Fan 7 Actual Speed in RPM	R	INT	411075	
Fan7Communications	Fan 7 Communications to PLC 0 = Offline 1 = Online	R	BOOL	411077	0
Fan7Spinning	0 = Fan is not spinning 1 = Fan is spinning	R	BOOL	411077	1
Fan7ActualDirection	0 = Fan 7 is in the forward direction 1 = Fan 7 is in the reverse direction	R	BOOL	411077	3
Fan7FaultStatus	0 = Fan 7 does not indicate a fault 1 = Fan 7 indicates a fault	R	BOOL	411077	4
Fan8CommandSpeedPct	Command % (of max rpm) sent to Fan 8	R	REAL	411080	
Fan8CommandSpeedRpm	Command RPM sent to Fan8	R	INT	411082	
Fan8ActualSpeedPct	Fan 8 Actual Speed in % of max rpm	R	REAL	411083	
Fan8ActualSpeedRpm	Fan 8 Actual Speed in RPM	R	INT	411085	
Fan8Communications	Fan 8 Communications to PLC 0 = Offline 1 = Online	R	BOOL	411087	0
Fan8Spinning	0 = Fan is not spinning 1 = Fan is spinning	R	BOOL	411087	1
Fan8ActualDirection	0 = Fan 8 is in the forward direction 1 = Fan 8 is in the reverse direction	R	BOOL	411087	3
Fan8FaultStatus	0 = Fan 8 does not indicate a fault 1 = Fan 8 indicates a fault	R	BOOL	411087	4
Fan9CommandSpeedPct	Command % (of max rpm) sent to Fan 9	R	REAL	411090	
Fan9CommandSpeedRpm	Command RPM sent to Fan9	R	INT	411092	
Fan9ActualSpeedPct	Fan 9 Actual Speed in % of max rpm	R	REAL	411093	
Fan9ActualSpeedRpm	Fan 9 Actual Speed in RPM	R	INT	411095	
Fan9Communications	Fan 9 Communications to PLC 0 = Offline	R	BOOL	411097	0

Table 69. Modbus RTU Communications, Points List, Fans

Variable	Description	R/W	Data Type	Modbus RTU Registers	Bit
	1 = Online				
Fan9Spinning	0 = Fan is not spinning 1 = Fan is spinning	R	BOOL	411097	1
Fan9ActualDirection	0 = Fan 9 is in the forward direction 1 = Fan 9 is in the reverse direction	R	BOOL	411097	3
Fan9FaultStatus	0 = Fan 9 does not indicate a fault 1 = Fan 9 indicates a fault	R	BOOL	411097	4
Fan10CommandSpeedPct	Command % (of max rpm) sent to Fan 10	R	REAL	411100	
Fan10CommandSpeedRpm	Command RPM sent to Fan10	R	INT	411102	
Fan10ActualSpeedPct	Fan 10 Actual Speed in % of max rpm	R	REAL	411103	
Fan10ActualSpeedRpm	Fan 10 Actual Speed in RPM	R	INT	411105	
Fan10Communications	Fan 10 Communications to PLC 0 = Offline 1 = Online	R	BOOL	411107	0
Fan10Spinning	0 = Fan is not spinning 1 = Fan is spinning	R	BOOL	411107	1
Fan10ActualDirection	0 = Fan 10 is in the forward direction 1 = Fan 10 is in the reverse direction	R	BOOL	411107	3
Fan10FaultStatus	0 = Fan 10 does not indicate a fault 1 = Fan 10 indicates a fault	R	BOOL	411107	4
Fan11CommandSpeedPct	Command % (of max rpm) sent to Fan 11	R	REAL	411110	
Fan11CommandSpeedRpm	Command RPM sent to Fan11	R	INT	411112	
Fan11ActualSpeedPct	Fan 11 Actual Speed in % of max rpm	R	REAL	411113	
Fan11ActualSpeedRpm	Fan 11 Actual Speed in RPM	R	INT	411115	
Fan11Communications	Fan 11 Communications to PLC 0 = Offline 1 = Online	R	BOOL	411117	0
Fan11Spinning	0 = Fan is not spinning 1 = Fan is spinning	R	BOOL	411117	1
Fan11ActualDirection	0 = Fan 11 is in the forward direction 1 = Fan 11 is in the	R	BOOL	411117	3

Table 69. Modbus RTU Communications, Points List, Fans

Variable	Description	R/W	Data Type	Modbus RTU Registers	Bit
	reverse direction				
Fan11FaultStatus	0 = Fan 11 does not indicate a fault 1 = Fan 11 indicates a fault	R	BOOL	411117	4
Fan12CommandSpeedPct	Command % (of max rpm) sent to Fan 12	R	REAL	411120	
Fan12CommandSpeedRpm	Command RPM sent to Fan12	R	INT	411122	
Fan12ActualSpeedPct	Fan 12 Actual Speed in % of max rpm	R	REAL	411123	
Fan12ActualSpeedRpm	Fan 12 Actual Speed in RPM	R	INT	411125	
Fan12Communications	Fan 12 Communications to PLC 0 = Offline 1 = Online	R	BOOL	411127	0
Fan12Spinning	0 = Fan is not spinning 1 = Fan is spinning	R	BOOL	411127	1
Fan12ActualDirection	0 = Fan 12 is in the forward direction 1 = Fan 12 is in the reverse direction	R	BOOL	411127	3
Fan12FaultStatus	0 = Fan 12 does not indicate a fault 1 = Fan 12 indicates a fault	R	BOOL	411127	4
Fan13CommandSpeedPct	Command % (of max rpm) sent to Fan 13	R	REAL	411130	
Fan13CommandSpeedRpm	Command RPM sent to Fan13	R	INT	411132	
Fan13ActualSpeedPct	Fan 13 Actual Speed in % of max rpm	R	REAL	411133	
Fan13ActualSpeedRpm	Fan 13 Actual Speed in RPM	R	INT	411135	
Fan13Communications	Fan 13 Communications to PLC 0 = Offline 1 = Online	R	BOOL	411137	0
Fan13Spinning	0 = Fan is not spinning 1 = Fan is spinning	R	BOOL	411137	1
Fan13ActualDirection	0 = Fan 13 is in the forward direction 1 = Fan 13 is in the reverse direction	R	BOOL	411137	3
Fan13FaultStatus	0 = Fan 13 does not indicate a fault 1 = Fan 13 indicates a fault	R	BOOL	411137	4

Table 69. Modbus RTU Communications, Points List, Fans

Variable	Description	R/W	Data Type	Modbus RTU Registers	Bit
Fan14CommandSpeedPct	Command % (of max rpm) sent to Fan 14	R	REAL	411140	
Fan14CommandSpeedRpm	Command RPM sent to Fan14	R	INT	411142	
Fan14ActualSpeedPct	Fan 14 Actual Speed in % of max rpm	R	REAL	411143	
Fan14ActualSpeedRpm	Fan 14 Actual Speed in RPM	R	INT	411145	
Fan14Communications	Fan 14 Communications to PLC 0 = Offline 1 = Online	R	BOOL	411147	0
Fan14Spinning	0 = Fan is not spinning 1 = Fan is spinning	R	BOOL	411147	1
Fan14ActualDirection	0 = Fan 14 is in the forward direction 1 = Fan 14 is in the reverse direction	R	BOOL	411147	3
Fan14FaultStatus	0 = Fan 14 does not indicate a fault 1 = Fan 14 indicates a fault	R	BOOL	411147	4
Fan15CommandSpeedPct	Command % (of max rpm) sent to Fan 15	R	REAL	411150	
Fan15CommandSpeedRpm	Command RPM sent to Fan15	R	INT	411152	
Fan15ActualSpeedPct	Fan 15 Actual Speed in % of max rpm	R	REAL	411153	
Fan15ActualSpeedRpm	Fan 15 Actual Speed in RPM	R	INT	411155	
Fan15Communications	Fan 15 Communications to PLC 0 = Offline 1 = Online	R	BOOL	411157	0
Fan15Spinning	0 = Fan is not spinning 1 = Fan is spinning	R	BOOL	411157	1
Fan15ActualDirection	0 = Fan 15 is in the forward direction 1 = Fan 15 is in the reverse direction	R	BOOL	411157	3
Fan15FaultStatus	0 = Fan 15 does not indicate a fault 1 = Fan 15 indicates a fault	R	BOOL	411157	4
Fan16CommandSpeedPct	Command % (of max rpm) sent to Fan 16	R	REAL	411160	
Fan16CommandSpeedRpm	Command RPM sent to Fan16	R	INT	411162	
Fan16ActualSpeedPct	Fan 16 Actual Speed in % of max rpm	R	REAL	411163	

Table 69. Modbus RTU Communications, Points List, Fans

Variable	Description	R/W	Data Type	Modbus RTU Registers	Bit
Fan16ActualSpeedRpm	Fan 16 Actual Speed in RPM	R	INT	411165	
Fan16Communications	Fan 16 Communications to PLC 0 = Offline 1 = Online	R	BOOL	411167	0
Fan16Spinning	0 = Fan is not spinning 1 = Fan is spinning	R	BOOL	411167	1
Fan16ActualDirection	0 = Fan 16 is in the forward direction 1 = Fan 16 is in the reverse direction	R	BOOL	411167	3
Fan16FaultStatus	0 = Fan 16 does not indicate a fault 1 = Fan 16 indicates a fault	R	BOOL	411167	4
Fan17CommandSpeedPct	Command % (of max rpm) sent to Fan 17	R	REAL	411170	
Fan17CommandSpeedRpm	Command RPM sent to Fan17	R	INT	411172	
Fan17ActualSpeedPct	Fan 17 Actual Speed in % of max rpm	R	REAL	411173	
Fan17ActualSpeedRpm	Fan 17 Actual Speed in RPM	R	INT	411175	
Fan17Communications	Fan 17 Communications to PLC 0 = Offline 1 = Online	R	BOOL	411177	0
Fan17Spinning	0 = Fan is not spinning 1 = Fan is spinning	R	BOOL	411177	1
Fan17ActualDirection	0 = Fan 17 is in the forward direction 1 = Fan 17 is in the reverse direction	R	BOOL	411177	3
Fan17FaultStatus	0 = Fan 17 does not indicate a fault 1 = Fan 17 indicates a fault	R	BOOL	411177	4
Fan18CommandSpeedPct	Command % (of max rpm) sent to Fan 18	R	REAL	411180	
Fan18CommandSpeedRpm	Command RPM sent to Fan18	R	INT	411182	
Fan18ActualSpeedPct	Fan 18 Actual Speed in % of max rpm	R	REAL	411183	
Fan18ActualSpeedRpm	Fan 18 Actual Speed in RPM	R	INT	411185	
Fan18Communications	Fan 18 Communications to PLC 0 = Offline 1 = Online	R	BOOL	411187	0

Table 69. Modbus RTU Communications, Points List, Fans					
Variable	Description	R/W	Data Type	Modbus RTU Registers	Bit
Fan18Spinning	0 = Fan is not spinning 1 = Fan is spinning	R	BOOL	411187	1
Fan18ActualDirection	0 = Fan 18 is in the forward direction 1 = Fan 18 is in the reverse direction	R	BOOL	411187	3
Fan18FaultStatus	0 = Fan 18 does not indicate a fault 1 = Fan 18 indicates a fault	R	BOOL	411187	4

Table 69. Modbus RTU Communications, Points List, Fans

Table 70. Modbus RTU Communications, Points List, Maintenance					
Variable	Description	Default	R/W	Data Type	Modbus RTU Registers
CoilCleanOverride	Immediately activates coil clean mode bypassing the configured schedule. If CoilCleanDuration is over, the unit expects a rising edge of the override to be activated again. 0 = Deactivate override 1 = Activate override	0	R/W	BOOL	412800
CoilCleanEnable	Enables coil clean feature based on a configured schedule and temperature limits. 0 = Disable feature 1 = Enable feature	0	R/W	BOOL	416800
MaintOATUpperLimit [0 - 122°F] [-17.77 – 50 °C]	Coil Clean feature runs based on CoilCleanEnable, the configured schedule and if CoilCleanOATLowerLimit > Outside Air Temperature < CoilCleanOATUpperLimit	86°F	R/W	REAL	416801
MaintLowerLimit [0 - 122°F] [-17.77 – 50 °C]	Coil Clean feature runs based on CoilCleanEnable, the configured schedule and if CoilCleanOATLowerLimit > Outside Air Temperature < CoilCleanOATUpperLimit	40°F	R/W	REAL	416803
CoilCleanDuration [3-20 min]	Duration in minutes of the Coil Clean Mode	5	R/W	USINT	416805
CoilCleanDays	0 = not enable day of week 1 = enable day of week Bit 0 = Sunday Bit 1 = Monday Bit 2 = Tuesday	111	R/W	USINT	416806

Table 70. Modbus RTU Communications, Points List, Maintenance

Variable	Description	Default	R/W	Data Type	Modbus RTU Registers
	Bit 3 = Wednesday Bit 4 = Thursday Bit 5 = Friday Bit 6 = Saturday Bit 7 = Reserved	1111b (127d)			
CoilCleanSundayStart [0000..2359]	Coil Clean Schedule Sunday Start time in HHMM format	0000	R/W	UINT	416807
CoilCleanMondayStart [0000..2359]	Coil Clean Schedule Monday Start time in HHMM format	0000	R/W	UINT	416808
CoilCleanTuesdayStart [0000..2359]	Coil Clean Schedule Tuesday Start time in HHMM format	0000	R/W	UINT	416809
CoilCleanWednesdayStart [0000..2359]	Coil Clean Schedule Wednesday Start time in HHMM format	0000	R/W	UINT	416810
CoilCleanThursdayStart [0000..2359]	Coil Clean Schedule Thursday Start time in HHMM format	0000	R/W	UINT	416811
CoilCleanFridayStart [0000..2359]	Coil Clean Schedule Friday Start time in HHMM format	0000	R/W	UINT	416812
CoilCleanSaturdayStart [0000..2359]	Coil Clean Schedule Saturday Start time in HHMM format	0000	R/W	UINT	416813
PadCleanOverride	Immediately activates Pad clean mode bypassing the configured schedule. If PadCleanDuration is over, the unit expects a rising edge of the override to be activated again. 0 = Deactivate override 1 = Activate override	0	R/W	BOOL	412801
PadCleanEnable	Enables Pad clean feature based on a configured schedule and temperature limits. 0 = Disable feature 1 = Enable feature	0	R/W	BOOL	416820
PadCleanDuration [3-20 min]	Duration in minutes of the Pad Clean Mode	5	R/W	USINT	416825
PadCleanDays	0 = not enable day of week 1 = enable day of week Bit 0 = Sunday Bit 1 = Monday Bit 2 = Tuesday Bit 3 = Wednesday Bit 4 = Thursday Bit 5 = Friday	111 1111b (127d)	R/W	USINT	416826

Table 70. Modbus RTU Communications, Points List, Maintenance

Variable	Description	Default	R/W	Data Type	Modbus RTU Registers
	Bit 6 = Saturday Bit 7= Reserved				
PadCleanSundayStart [0000..2359]	Pad Clean Schedule Sunday Start time in HHMM format	0000	R/W	UINT	416827
PadCleanMondayStart [0000..2359]	Pad Clean Schedule Monday Start time in HHMM format	0000	R/W	UINT	416828
PadCleanTuesdayStart [0000..2359]	Pad Clean Schedule Tuesday Start time in HHMM format	0000	R/W	UINT	416829
PadCleanWednesdayStart [0000..2359]	Pad Clean Schedule Wednesday Start time in HHMM format	0000	R/W	UINT	416830
PadCleanThursdayStart [0000..2359]	Pad Clean Schedule Thursday Start time in HHMM format	0000	R/W	UINT	416831
PadCleanFridayStart [0000..2359]	Pad Clean Schedule Friday Start time in HHMM format	0000	R/W	UINT	416832
PadCleanSaturdayStart [0000..2359]	Pad Clean Schedule Saturday Start time in HHMM format	0000	R/W	UINT	416833
DrainDryOverride	Immediately activates Drain Dry mode bypassing the configured schedule. If Drain Dry Duration is over, the unit expects a rising edge of the override to be activated again. 0 = Deactivate override 1 = Activate override	0	R/W	BOOL	412802
DrainDryEnable	Enables Drain Dry feature based on a configured schedule and temperature limits. 0 = Disable feature 1 = Enable feature	0	R/W	BOOL	416840
DrainDryDuration [3-20 min]	Duration in minutes of the Drain Dry Mode	5	R/W	USINT	416845
DrainDryDays	0 = not enable day of week 1 = enable day of week Bit 0 = Sunday Bit 1 = Monday Bit 2 = Tuesday Bit 3 = Wednesday Bit 4 = Thursday Bit 5 = Friday Bit 6 = Saturday Bit 7= Reserved	111 1111b (127d)	R/W	USINT	416846

Table 70. Modbus RTU Communications, Points List, Maintenance					
Variable	Description	Default	R/W	Data Type	Modbus RTU Registers
DrainDrySundayStart [0000..2359]	Drain Dry Schedule Sunday Start time in HHMM format	0000	R/W	UINT	416847
DrainDryMondayStart [0000..2359]	Drain Dry Schedule Monday Start time in HHMM format	0000	R/W	UINT	416848
DrainDryTuesdayStart [0000..2359]	Drain Dry Schedule Tuesday Start time in HHMM format	0000	R/W	UINT	416849
DrainDryWednesdayStart [0000..2359]	Drain Dry Schedule Wednesday Start time in HHMM format	0000	R/W	UINT	416850
DrainDryThursdayStart [0000..2359]	Drain Dry Schedule Thursday Start time in HHMM format	0000	R/W	UINT	416851
DrainDryFridayStart [0000..2359]	Drain Dry Schedule Friday Start time in HHMM format	0000	R/W	UINT	416852
DrainDrySaturdayStart [0000..2359]	Drain Dry Schedule Saturday Start time in HHMM format	0000	R/W	UINT	416853

Table 70. Modbus RTU Communications, Points List, Maintenance

Table 71 Modbus RTU Communications, Points List, Load Limiting					
Variable	Description	Default	R/W	Data Type	Modbus RTU Registers
NightQuietOverride	Immediately activates fans to run at NightQuietMaxSpeedPct, bypassing the configured schedule. 0 = Deactivate override 1 = Activate override	0	R/W	BOOL	412700
NightQuietRun	0 = Night Quiet mode is not active 1 = Night Quiet mode is active	-	R	BOOL	412701
NightQuietEnable	Enables fans to run at NightQuietMaxSpeedPct based on the configured schedule. 0 = Disable feature 1 = Enable feature	0	R/W	BOOL	416700
NightQuietMaxSpeedPct [25..100]	Maximum Speed during Night Quiet Mode in %	90	R/W	REAL	416701
NightQuietSundayStart [0000..2359]	Night Quiet Schedule Sunday Start time in HHMM format – must be greater than Sunday Stop Time	0000	R/W	UINT	416703
NightQuietSundayStop [0000..2359]	Night Quiet Schedule Sunday Stop time in HHMM format – must be less than Sunday Start Time	0000	R/W	UINT	416704
NightQuietMondayStart	Night Quiet Schedule Monday Start time in HHMM format – must	0000	R/W	UINT	416705

Table 71 Modbus RTU Communications, Points List, Load Limiting

Variable	Description	Default	R/W	Data Type	Modbus RTU Registers
[0000..2359]	be greater than Monday Stop Time				
NightQuietMondayStop [0000..2359]	Night Quiet Schedule Monday Stop time in HHMM format – must be less than Monday Start time	0000	R/W	UINT	416706
NightQuietTuesdayStart [0000..2359]	Night Quiet Schedule Tuesday Start time in HHMM format - must be greater than Tuesday Stop Time	0000	R/W	UINT	416707
NightQuietTuesdayStop [0000..2359]	Night Quiet Schedule Tuesday Stop time in HHMM format – must be less than Tuesday Start time	0000	R/W	UINT	416708
NightQuietWednesdayStart [0000..2359]	Night Quiet Schedule Wednesday Start time in HHMM format – must be greater than Wednesday Stop Time	0000	R/W	UINT	416709
NightQuietWednesdayStop [0000..2359]	Night Quiet Schedule Wednesday Stop time in HHMM format – must be less than Wednesday Start Time	0000	R/W	UINT	416710
NightQuietThursdayStart [0000..2359]	Night Quiet Schedule Thursday Start time in HHMM format – must be greater than Thursday Stop Time	0000	R/W	UINT	416711
NightQuietThursdayStop [0000..2359]	Night Quiet Schedule Thursday Stop time in HHMM format – must be less than Thursday Start Time	0000	R/W	UINT	416712
NightQuietFridayStart [0000..2359]	Night Quiet Schedule Friday Start time in HHMM format – must be greater than Friday Stop Time	0000	R/W	UINT	416713
NightQuietFridayStop [0000..2359]	Night Quiet Schedule Friday Stop time in HHMM format – must be less than Friday Start Time	0000	R/W	UINT	416714
NightQuietSaturdayStart [0000..2359]	Night Quiet Schedule Saturday Start time in HHMM format – must be greater than Saturday Stop Time	0000	R/W	UINT	416715
NightQuietSaturdayStop [0000..2359]	Night Quiet Schedule Saturday Stop time in HHMM format – must be less than Saturday Start Time	0000	R/W	UINT	416716
NightQuietDays	0 = not enable overnight 1 = enable overnight Bit 0 = Sunday to Monday Bit 1 = Monday to Tuesday Bit 2 = Tuesday to Wednesday Bit 3 = Wednesday to Thursday Bit 4 = Thursday to Friday Bit 5 = Friday to Saturday Bit 6 = Saturday to Sunday	000 0000b (0d)	R/W	USINT	416717

Table 71 Modbus RTU Communications, Points List, Load Limiting

Variable	Description	Default	R/W	Data Type	Modbus RTU Registers
	Bit 7= Reserved				
NightDryOverride	Immediately activates fans to run at NightQuietMaxSpeedPct, bypassing the configured schedule. 0 = Deactivate override 1 = Activate override	0	R/W	BOOL	412702
NightDryRun	0 = Night Quiet mode is not active 1 = Night Quiet mode is active	-	R	BOOL	412703
NightDryEnable	Enables fans to run at NightQuietMaxSpeedPct based on the configured schedule. 0 = Disable feature 1 = Enable feature	0	R/W	BOOL	416720
NightDrySundayStart [0000..2359]	Night Quiet Schedule Sunday Start time in HHMM format – must be greater than Sunday Stop Time	0000	R/W	UINT	416721
NightDrySundayStop [0000..2359]	Night Quiet Schedule Sunday Stop time in HHMM format – must be less than Sunday Start Time	0000	R/W	UINT	416722
NightDryMondayStart [0000..2359]	Night Quiet Schedule Monday Start time in HHMM format – must be greater than Monday Stop Time	0000	R/W	UINT	416723
NightDryMondayStop [0000..2359]	Night Quiet Schedule Monday Stop time in HHMM format – must be less than Monday Start time	0000	R/W	UINT	416724
NightDryTuesdayStart [0000..2359]	Night Quiet Schedule Tuesday Start time in HHMM format - must be greater than Tuesday Stop Time	0000	R/W	UINT	416725
NightDryTuesdayStop [0000..2359]	Night Quiet Schedule Tuesday Stop time in HHMM format – must be less than Tuesday Start time	0000	R/W	UINT	416726
NightDryWednesdayStart [0000..2359]	Night Quiet Schedule Wednesday Start time in HHMM format – must be greater than Wednesday Stop Time	0000	R/W	UINT	416727
NightDryWednesdayStop [0000..2359]	Night Quiet Schedule Wednesday Stop time in HHMM format – must be less than Wednesday Start Time	0000	R/W	UINT	416728
NightDryThursdayStart [0000..2359]	Night Quiet Schedule Thursday Start time in HHMM format – must be greater than Thursday Stop Time	0000	R/W	UINT	416729
NightDryThursdayStop [0000..2359]	Night Quiet Schedule Thursday Stop time in HHMM format – must be less than Thursday Start Time	0000	R/W	UINT	416730

Table 71 Modbus RTU Communications, Points List, Load Limiting

Variable	Description	Default	R/W	Data Type	Modbus RTU Registers
NightDryFridayStart [0000..2359]	Night Quiet Schedule Friday Start time in HHMM format – must be greater than Friday Stop Time	0000	R/W	UINT	416731
NightDryFridayStop [0000..2359]	Night Quiet Schedule Friday Stop time in HHMM format – must be less than Friday Start Time	0000	R/W	UINT	416732
NightDrySaturdayStart [0000..2359]	Night Quiet Schedule Saturday Start time in HHMM format – must be greater than Saturday Stop Time	0000	R/W	UINT	416733
NightDrySaturdayStop [0000..2359]	Night Quiet Schedule Saturday Stop time in HHMM format – must be less than Saturday Start Time	0000	R/W	UINT	416734
NightDryDays	0 = not enable overnight 1 = enable overnight Bit 0 = Sunday to Monday Bit 1 = Monday to Tuesday Bit 2 = Tuesday to Wednesday Bit 3 = Wednesday to Thursday Bit 4 = Thursday to Friday Bit 5 = Friday to Saturday Bit 6 = Saturday to Sunday Bit 7= Reserved	000 0000b (0d)	R/W	USINT	416735
ScheduleDryOverride	Immediately activates fans to run at NightQuietMaxSpeedPct, bypassing the configured schedule. 0 = Deactivate override 1 = Activate override	0	R/W	BOOL	412704
ScheduleDryRun	0 = Night Quiet mode is not active 1 = Night Quiet mode is active	-	R	BOOL	412705
ScheduleDryEnable	Enables fans to run at NightQuietMaxSpeedPct based on the configured schedule. 0 = Disable feature 1 = Enable feature	0	R/W	BOOL	416740
ScheduleDrySundayStart [0000..2359]	Night Quiet Schedule Sunday Start time in HHMM format – must be greater than Sunday Stop Time	0000	R/W	UINT	416741
ScheduleDrySundayStop [0000..2359]	Night Quiet Schedule Sunday Stop time in HHMM format – must be less than Sunday Start Time	0000	R/W	UINT	416742
ScheduleDryMondayStart [0000..2359]	Night Quiet Schedule Monday Start time in HHMM format – must be greater than Monday Stop Time	0000	R/W	UINT	416743
ScheduleDryMondayStop	Night Quiet Schedule Monday Stop time in HHMM format – must	0000	R/W	UINT	416744

Table 71 Modbus RTU Communications, Points List, Load Limiting					
Variable	Description	Default	R/W	Data Type	Modbus RTU Registers
[0000..2359]	be less than Monday Start time				
ScheduleDryTuesday Start [0000..2359]	Night Quiet Schedule Tuesday Start time in HHMM format - must be greater than Tuesday Stop Time	0000	R/W	UINT	416745
ScheduleDryTuesday Stop [0000..2359]	Night Quiet Schedule Tuesday Stop time in HHMM format – must be less than Tuesday Start time	0000	R/W	UINT	416746
ScheduleDryWednesday Start [0000..2359]	Night Quiet Schedule Wednesday Start time in HHMM format – must be greater than Wednesday Stop Time	0000	R/W	UINT	416747
ScheduleDryWednesday Stop [0000..2359]	Night Quiet Schedule Wednesday Stop time in HHMM format – must be less than Wednesday Start Time	0000	R/W	UINT	416748
ScheduleDryThursday Start [0000..2359]	Night Quiet Schedule Thursday Start time in HHMM format – must be greater than Thursday Stop Time	0000	R/W	UINT	416749
ScheduleDryThursday Stop [0000..2359]	Night Quiet Schedule Thursday Stop time in HHMM format – must be less than Thursday Start Time	0000	R/W	UINT	416750
ScheduleDryFriday Start [0000..2359]	Night Quiet Schedule Friday Start time in HHMM format – must be greater than Friday Stop Time	0000	R/W	UINT	416751
ScheduleDryFriday Stop [0000..2359]	Night Quiet Schedule Friday Stop time in HHMM format – must be less than Friday Start Time	0000	R/W	UINT	416752
ScheduleDrySaturday Start [0000..2359]	Night Quiet Schedule Saturday Start time in HHMM format – must be greater than Saturday Stop Time	0000	R/W	UINT	416753
ScheduleDrySaturday Stop [0000..2359]	Night Quiet Schedule Saturday Stop time in HHMM format – must be less than Saturday Start Time	0000	R/W	UINT	416754
ScheduleDryDays	0 = not enable overnight 1 = enable overnight Bit 0 = Sunday to Monday Bit 1 = Monday to Tuesday Bit 2 = Tuesday to Wednesday Bit 3 = Wednesday to Thursday Bit 4 = Thursday to Friday Bit 5 = Friday to Saturday Bit 6 = Saturday to Sunday Bit 7= Reserved	000 0000b (0d)	R/W	USINT	416755

Table 71 Modbus RTU Communications, Points List, Load Limiting

BACnet Communications, Points List

Table 72: BACnet Communications, Points List, Unit Control

Variable	Description	Default	R/W	Data Type	BACnet Identifier
ImperialUnits	Selects the unit of parameters indicating power, temperature, torque, and vibration. 0 = Metric units (kW, °C, Nm, mm/sec) 1 = Imperial Units (hp, °F, ftlb, in/sec)	1	R/W	BOOL	BV0
BMSRunEnable	BMS Run Enable 0 = Off 1 = On	0	R/W	BOOL	BV1
CISetpoint	The desired setpoint of a unit configured for "Customer Input Control" in units of % Max Fan Speed.	-	R/W	REAL	AV0
LFTSetpoint	The leaving fluid temperature setpoint of a unit configured for "LFT Control" in units of °C/ °F	-	R/W	REAL	AV1
LFTDeadband [0-10°]	Leaving Fluid Temperature Control Deadband	0.2	R/W	REAL	AV2
LFTProportionalGain [0-300]	Leaving Fluid Temperature Control Proportional Gain	10.0	R/W	REAL	AV3
LFTIntegralTime [0-6000]	Leaving Fluid Temperature Control Integral Time (Ti)	100.0	R/W	REAL	AV4
WaterEnable	Water Usage Disable. Forces the unit into dry mode 0 = Water Usage Disabled 1 = Water Usage Enabled	0	R/W	BOOL	BV2
PumpEnable	Enables pump usage when unit is configured for BMS pump enable: 0 = Pump Usage Disabled 1 = Water Usage Enabled	1	R/W	BOOL	BV3

Table 72: BACnet Communications, Points List, Unit Control

Variable	Description	Default	R/W	Data Type	BACnet Identifier
RESERVED	RESERVED FOR ADDITIONAL UNIT CONTROL SETTINGS	0	R/W	BOOL	BV4
ControlRange	Control Range in °C/ °F	1	R/W	REAL	AV5
AdiabaticSwitchpoint	Adiabatic Switchpoint in °C/ °F		R/W	REAL	AV6
RESERVED	RESERVED FOR ADDITIONAL UNIT CONTROL SETTINGS	-	R/W	-	BV5
RESERVED	RESERVED FOR ADDITIONAL UNIT CONTROL SETTINGS	-	R/W	-	BV6
RESERVED	RESERVED FOR ADDITIONAL UNIT CONTROL SETTINGS	-	R/W	-	BV7
RESERVED	RESERVED FOR ADDITIONAL UNIT CONTROL SETTINGS	-	R/W	-	BV8
RESERVED	RESERVED FOR ADDITIONAL UNIT CONTROL SETTINGS	-	R/W	-	BV9
RESERVED	RESERVED FOR ADDITIONAL UNIT CONTROL SETTINGS	-	R/W	-	AV7
RESERVED	RESERVED FOR ADDITIONAL UNIT CONTROL SETTINGS	-	R/W	-	AV8
RESERVED	RESERVED FOR ADDITIONAL UNIT CONTROL SETTINGS	-	R/W	-	AV9
RESERVED	RESERVED FOR ADDITIONAL UNIT CONTROL SETTINGS	-	R/W	-	AV10
RESERVED	RESERVED FOR ADDITIONAL UNIT CONTROL SETTINGS	-	R/W	-	AV11

Table 72: BACnet Communications, Points List, Unit Control

Table 73: BACnet Communications, Points List, Unit Monitoring

Variable	Description	R/W	Data Type	BACnet Identifier
ControlState	Unit State 0 = Undefined 1 = Off 2 = Manual	R	INT	AI0

Table 73: BACNet Communications, Points List, Unit Monitoring				
Variable	Description	R/W	Data Type	BACnet Identifier
	3 = Dry 4 = Single 5 = Dual 6 = Coil Clean 7 = Wet Coil Clean 8 = Pad Clean 9 = Drain Dry 10 = Emergency			
LeavingFluidTemperature	Leaving Fluid Temperature in °C/°F	R	REAL	AI1
OutsideAirTemperature	Outside Air Temperature in °C/°F	R	REAL	AI3
RESERVED	RESERVED FOR MORE TEMPERATURE INPUTS	R	-	AI4
RESERVED	RESERVED FOR MORE TEMPERATURE INPUTS	R	-	AI5
Precooler1Temperature	Precooler 1 Temperature in °C/°F	R	REAL	AI6
Precooler2Temperature	Precooler 2 Temperature in °C/°F	R	REAL	AI7
RESERVED	RESERVED FOR MORE TEMPERATURE INPUTS	R	-	AI8
RESERVED	RESERVED FOR MORE TEMPERATURE INPUTS	R	-	AI9
RESERVED	RESERVED FOR MORE TEMPERATURE INPUTS	R	-	AI10
RESERVED	RESERVED FOR MORE TEMPERATURE INPUTS	R	-	AI11
BasinLevel	Basin Level 0 = Undefined 1 = Pump Cutout 2 = Low 3 = Mid 4 = High	R	USINT	AI13
RESERVED	RESERVED FOR MORE INPUTS	R	-	AI14
RESERVED	RESERVED FOR MORE INPUTS	R	-	AI15
RESERVED	RESERVED FOR MORE INPUTS	R	-	AI16
RESERVED	RESERVED FOR MORE INPUTS	R	-	AI17
RESERVED	RESERVED FOR MORE INPUTS	R	-	AI18
RESERVED	RESERVED FOR MORE INPUTS	R	-	AI19

Table 73: BACNet Communications, Points List, Unit Monitoring

Table 74: BACNet Communications, Points List, Fans

Variable	Description	R/W	Data Type	BACnet Identifier	Bit
AllFansCommandPct	Average command speed of all fans in units of % Max Speed	R	REAL	AI20	-
AllFansCommandRpm	Average command speed of all fans in units of RPM	R	INT	AI21	-
AverageFanSpeedRpm	Average speed of all fans in units of RPM	R	INT	AI22	-
AverageFanPower	Average power draw of all fans	R	REAL	AI23	-
Fan1ActualSpeedRpm	Fan 1 Actual Speed in RPM	R	INT	AI24	-
Fan1Status - Fan1Communications	Fan 1 VFD Communications to PLC 0 = Offline 1 = Online	R	BOOL	AI25	0
Fan1Status - Fan1Spinning	0 = Fan is not spinning 1 = Fan is spinning	R	BOOL	AI25	1
Fan1Status - Fan1ActualDirection	0 = Fan 1 is in the forward direction 1 = Fan 1 is in the reverse direction	R	BOOL	AI25	3
Fan1Status - Fan1FaultStatus	0 = Fan 1 does not indicate a fault 1 = Fan 1 indicates a fault	R	BOOL	AI25	4
Fan2ActualSpeedRpm	Fan 2 Actual Speed in RPM	R	INT	AI26	-
Fan2Status - Fan2Communications	Fan 2 Communications to PLC 0 = Offline 1 = Online	R	BOOL	AI27	0
Fan2Status - Fan2Spinning	0 = Fan is not spinning 1 = Fan is spinning	R	BOOL	AI27	1
Fan2Status - Fan2ActualDirection	0 = Fan 2 is in the forward direction 1 = Fan 2 is in the reverse direction	R	BOOL	AI27	3
Fan2Status - Fan2FaultStatus	0 = Fan 2 does not indicate a fault 1 = Fan 2 indicates a fault	R	BOOL	AI27	4
Fan3ActualSpeedRpm	Fan 3 Actual Speed in RPM	R	INT	AI28	-
Fan3Status - Fan3Communications	Fan 3 Communications to PLC 0 = Offline 1 = Online	R	BOOL	AI29	0
Fan3Status - Fan3Spinning	0 = Fan is not spinning 1 = Fan is spinning	R	BOOL	AI29	1

Table 74: BACnet Communications, Points List, Fans

Variable	Description	R/W	Data Type	BACnet Identifier	Bit
Fan3Status - Fan3ZeroSpeed	0 = Fan 3 is at zero speed 1 = Fan 3 not at zero speed	R	BOOL	AI29	2
Fan3Status - Fan3ActualDirection	0 = Fan 3 is in the forward direction 1 = Fan 3 is in the reverse direction	R	BOOL	AI29	3
Fan3Status - Fan3FaultStatus	0 = Fan 3 does not indicate a fault 1 = Fan 3 indicates a fault	R	BOOL	AI29	4
Fan4ActualSpeedRpm	Fan 4 Actual Speed in RPM	R	INT	AI30	-
Fan4Status - Fan4Communications	Fan 4 Communications to PLC 0 = Offline 1 = Online	R	BOOL	AI31	0
Fan4Status - Fan4Spinning	0 = Fan is not spinning 1 = Fan is spinning	R	BOOL	AI31	1
Fan4Status - Fan4ZeroSpeed	0 = Fan 4 is at zero speed 1 = Fan 4 not at zero speed	R	BOOL	AI31	2
Fan4Status - Fan4ActualDirection	0 = Fan 4 is in the forward direction 1 = Fan 4 is in the reverse direction	R	BOOL	AI31	3
Fan4Status - Fan4FaultStatus	0 = Fan 4 does not indicate a fault 1 = Fan 4 indicates a fault	R	BOOL	AI31	4
Fan5ActualSpeedRpm	Fan 5 Actual Speed in RPM	R	INT	AI32	-
Fan5Status - Fan5Communications	Fan 5 Communications to PLC 0 = Offline 1 = Online	R	BOOL	AI33	0
Fan5Status - Fan5Spinning	0 = Fan is not spinning 1 = Fan is spinning	R	BOOL	AI33	1
Fan5Status - Fan5ActualDirection	0 = Fan 5 is in the forward direction 1 = Fan 5 is in the reverse direction	R	BOOL	AI33	3
Fan5Status - Fan5FaultStatus	0 = Fan 5 does not indicate a fault 1 = Fan 5 indicates a fault	R	BOOL	AI33	4
Fan6ActualSpeedRpm	Fan 6 Actual Speed in RPM	R	INT	AI34	-
Fan6Status - Fan6Communications	Fan 6 Communications to PLC 0 = Offline 1 = Online	R	BOOL	AI35	0

Table 74: BACnet Communications, Points List, Fans

Variable	Description	R/W	Data Type	BACnet Identifier	Bit
Fan6Status - Fan6Spinning	0 = Fan is not spinning 1 = Fan is spinning	R	BOOL	AI35	1
Fan6Status - Fan6ActualDirection	0 = Fan 6 is in the forward direction 1 = Fan 6 is in the reverse direction	R	BOOL	AI35	3
Fan6Status - Fan6FaultStatus	0 = Fan 6 does not indicate a fault 1 = Fan 6 indicates a fault	R	BOOL	AI35	4
Fan7ActualSpeedRpm	Fan 7 Actual Speed in RPM	R	INT	AI36	-
Fan7Status - Fan7Communications	Fan 7 Communications to PLC 0 = Offline 1 = Online	R	BOOL	AI37	0
Fan7Status - Fan7Spinning	0 = Fan is not spinning 1 = Fan is spinning	R	BOOL	AI37	1
Fan7Status - Fan7ActualDirection	0 = Fan 7 is in the forward direction 1 = Fan 7 is in the reverse direction	R	BOOL	AI37	3
Fan7Status - Fan7FaultStatus	0 = Fan 7 does not indicate a fault 1 = Fan 7 indicates a fault	R	BOOL	AI37	4
Fan8ActualSpeedRpm	Fan 8 Actual Speed in RPM	R	INT	AI38	-
Fan8Status - Fan8Communications	Fan 8 Communications to PLC 0 = Offline 1 = Online	R	BOOL	AI39	0
Fan8Status - Fan8Spinning	0 = Fan is not spinning 1 = Fan is spinning	R	BOOL	AI39	1
Fan8Status - Fan8ActualDirection	0 = Fan 8 is in the forward direction 1 = Fan 8 is in the reverse direction	R	BOOL	AI39	3
Fan8Status - Fan8FaultStatus	0 = Fan 8 does not indicate a fault 1 = Fan 8 indicates a fault	R	BOOL	AI39	4
Fan9ActualSpeedRpm	Fan 9 Actual Speed in RPM	R	INT	AI40	-
Fan9Status - Fan9Communications	Fan 9 Communications to PLC 0 = Offline 1 = Online	R	BOOL	AI41	0
Fan9Status - Fan9Spinning	0 = Fan is not spinning 1 = Fan is spinning	R	BOOL	AI41	1
Fan9Status - Fan9ActualDirection	0 = Fan 9 is in the forward direction	R	BOOL	AI41	3

Table 74: BACnet Communications, Points List, Fans

Variable	Description	R/W	Data Type	BACnet Identifier	Bit
	1 = Fan 9 is in the reverse direction				
Fan9Status - Fan9FaultStatus	0 = Fan 9 does not indicate a fault 1 = Fan 9 indicates a fault	R	BOOL	AI41	4
Fan10ActualSpeedRpm	Fan 10 Actual Speed in RPM	R	INT	AI42	-
Fan10Status - Fan10Communications	Fan 10 Communications to PLC 0 = Offline 1 = Online	R	BOOL	AI43	0
Fan10Status - Fan10Spinning	0 = Fan is not spinning 1 = Fan is spinning	R	BOOL	AI43	1
Fan10Status - Fan10ActualDirection	0 = Fan 10 is in the forward direction 1 = Fan 10 is in the reverse direction	R	BOOL	AI43	3
Fan10Status - Fan10FaultStatus	0 = Fan 10 does not indicate a fault 1 = Fan 10 indicates a fault	R	BOOL	AI43	4
Fan11ActualSpeedRpm	Fan 11 Actual Speed in RPM	R	INT	AI44	-
Fan11Status - Fan11Communications	Fan 11 Communications to PLC 0 = Offline 1 = Online	R	BOOL	AI45	0
Fan11Status - Fan11Spinning	0 = Fan is not spinning 1 = Fan is spinning	R	BOOL	AI45	1
Fan11Status - Fan11ActualDirection	0 = Fan 11 is in the forward direction 1 = Fan 11 is in the reverse direction	R	BOOL	AI45	3
Fan11Status - Fan11FaultStatus	0 = Fan 11 does not indicate a fault 1 = Fan 11 indicates a fault	R	BOOL	AI45	4
Fan12ActualSpeedRpm	Fan 12 Actual Speed in RPM	R	INT	AI46	-
Fan12Status - Fan12Communications	Fan 12 Communications to PLC 0 = Offline 1 = Online	R	BOOL	AI47	0
Fan12Status - Fan12Spinning	0 = Fan is not spinning 1 = Fan is spinning	R	BOOL	AI47	1
Fan12Status - Fan12ActualDirection	0 = Fan 12 is in the forward direction 1 = Fan 12 is in the reverse direction	R	BOOL	AI47	3

Table 74: BACnet Communications, Points List, Fans

Variable	Description	R/W	Data Type	BACnet Identifier	Bit
Fan12Status - Fan12FaultStatus	0 = Fan 12 does not indicate a fault 1 = Fan 12 indicates a fault	R	BOOL	AI47	4
Fan13ActualSpeedRpm	Fan 13 Actual Speed in RPM	R	INT	AI48	-
Fan13Status - Fan13Communications	Fan 13 Communications to PLC 0 = Offline 1 = Online	R	BOOL	AI49	0
Fan13Status - Fan13Spinning	0 = Fan is not spinning 1 = Fan is spinning	R	BOOL	AI49	1
Fan13Status - Fan13ActualDirection	0 = Fan 13 is in the forward direction 1 = Fan 13 is in the reverse direction	R	BOOL	AI49	3
Fan13Status - Fan13FaultStatus	0 = Fan 13 does not indicate a fault 1 = Fan 13 indicates a fault	R	BOOL	AI49	4
Fan14ActualSpeedRpm	Fan 14 Actual Speed in RPM	R	INT	AI50	-
Fan14Status - Fan14Communications	Fan 14 Communications to PLC 0 = Offline 1 = Online	R	BOOL	AI51	0
Fan14Status - Fan14Spinning	0 = Fan is not spinning 1 = Fan is spinning	R	BOOL	AI51	1
Fan14Status - Fan14ActualDirection	0 = Fan 14 is in the forward direction 1 = Fan 14 is in the reverse direction	R	BOOL	AI51	3
Fan14Status - Fan14FaultStatus	0 = Fan 14 does not indicate a fault 1 = Fan 14 indicates a fault	R	BOOL	AI51	4
Fan15ActualSpeedRpm	Fan 15 Actual Speed in RPM	R	INT	AI52	-
Fan15Status - Fan15Communications	Fan 15 Communications to PLC 0 = Offline 1 = Online	R	BOOL	AI53	0
Fan15Status - Fan15Spinning	0 = Fan is not spinning 1 = Fan is spinning	R	BOOL	AI53	1
Fan15Status - Fan15ActualDirection	0 = Fan 15 is in the forward direction 1 = Fan 15 is in the reverse direction	R	BOOL	AI53	3
Fan15Status - Fan15FaultStatus	0 = Fan 15 does not indicate a fault	R	BOOL	AI53	4

Table 74: BACnet Communications, Points List, Fans

Variable	Description	R/W	Data Type	BACnet Identifier	Bit
	1 = Fan 15 indicates a fault				
Fan16ActualSpeedRpm	Fan 16 Actual Speed in RPM	R	INT	A154	-
Fan16Status - Fan16Communications	Fan 16 Communications to PLC 0 = Offline 1 = Online	R	BOOL	A155	0
Fan16Status - Fan16Spinning	0 = Fan is not spinning 1 = Fan is spinning	R	BOOL	A155	1
Fan16Status - Fan16ActualDirection	0 = Fan 16 is in the forward direction 1 = Fan 16 is in the reverse direction	R	BOOL	A155	3
Fan16Status - Fan16FaultStatus	0 = Fan 16 does not indicate a fault 1 = Fan 16 indicates a fault	R	BOOL	A155	4
Fan17ActualSpeedRpm	Fan 17 Actual Speed in RPM	R	INT	A156	-
Fan17Status - Fan17Communications	Fan 17 Communications to PLC 0 = Offline 1 = Online	R	BOOL	A157	0
Fan17Status - Fan17Spinning	0 = Fan is not spinning 1 = Fan is spinning	R	BOOL	A157	1
Fan17Status - Fan17ZeroSpeed	0 = Fan 17 is at zero speed 1 = Fan 17 not at zero speed	R	BOOL	A157	2
Fan17Status - Fan17ActualDirection	0 = Fan 17 is in the forward direction 1 = Fan 17 is in the reverse direction	R	BOOL	A157	3
Fan17Status - Fan17FaultStatus	0 = Fan 17 does not indicate a fault 1 = Fan 17 indicates a fault	R	BOOL	A157	4
Fan18ActualSpeedRpm	Fan 18 Actual Speed in RPM	R	INT	A158	-
Fan18Status - Fan18Communications	Fan 18 Communications to PLC 0 = Offline 1 = Online	R	BOOL	A159	0
Fan18Status - Fan18Spinning	0 = Fan is not spinning 1 = Fan is spinning	R	BOOL	A159	1
Fan18Status - Fan18ActualDirection	0 = Fan 18 is in the forward direction 1 = Fan 18 is in the reverse direction	R	BOOL	A159	3

Table 74: BACNet Communications, Points List, Fans

Variable	Description	R/W	Data Type	BACnet Identifier	Bit
Fan18Status - Fan18FaultStatus	0 = Fan 18 does not indicate a fault 1 = Fan 18 indicates a fault	R	BOOL	AI59	4

Table 74: BACNet Communications, Points List, Fans

Table 75: BACNet Communications, Points List, Coil Cleaning

Variable	Description	Default	R/W	Data Type	BACnet Identifier
CoilCleanOverride	Immediately activates coil clean mode bypassing the configured schedule. If CoilCleanDuration is over, the unit expects a rising edge of the override to be activated again. 0 = Deactivate override 1 = Activate override	0	R/W	BOOL	BV10
RESERVED	RESERVED FOR "RUN" BIT	-	R	-	BV11
CoilCleanEnable	Enables coil clean feature based on a configured schedule and temperature limits. 0 = Disable feature 1 = Enable feature	0	R/W	BOOL	BV12
CoilCleanDays	0 = not enable day of week 1 = enable day of week Bit 0 = Sunday Bit 1 = Monday Bit 2 = Tuesday Bit 3 = Wednesday Bit 4 = Thursday Bit 5 = Friday Bit 6 = Saturday Bit 7 = Reserved	111 1111b (127d)	R/W	USINT	AV12

Table 75: BACNet Communications, Points List, Coil Cleaning

Table 76: BACNet Communications, Points List, Night Quiet

Variable	Description	Default	R/W	Data Type	BACnet Identifier
NightQuietOverride	Immediately activates fans to run at NightQuietMaxSpeedPct, bypassing the configured schedule. 0 = Deactivate override 1 = Activate override	0	R/W	BOOL	BV13
NightQuietRun	0 = Night Quiet mode is not active 1 = Night Quiet mode is active	-	R	BOOL	BV14
NightQuietEnable	Enables fans to run at NightQuietMaxSpeedPct based on the configured schedule. 0 = Disable feature 1 = Enable feature	0	R/W	BOOL	BV15
NightQuietDays	0 = not enable overnight 1 = enable overnight Bit 0 = Sunday to Monday Bit 1 = Monday to Tuesday Bit 2 = Tuesday to Wednesday Bit 3 = Wednesday to Thursday Bit 4 = Thursday to Friday Bit 5 = Friday to Saturday Bit 6 = Saturday to Sunday Bit 7= Reserved	000 0000b (0d)	R/W	USINT	AV13

*Table 76: BACNet Communications, Points List, Night Quiet***Table 77: BACNet Communications, Points List, Night Dry**

Variable	Description	Default	R/W	Data Type	BACnet Identifier
NightDryOverride		-	R/W		BV16
NightDryRun		-	R		BV17
NightDryEnable		-	R/W		BV18
NightDryays		-	R/W		AV14

*Table 77: BACNet Communications, Points List, Night Dry***Table 78: BACNet Communications, Points List, Schedule Dry**

Variable	Description	Default	R/W	Data Type	BACnet Identifier
ScheduleDryOverride		-	R/W		BV19
ScheduleDryRun		-	R		BV20

ScheduleDryEnable		-	R/W		BV21
ScheduleDryDays		-	R/W		AV15

Table 78: BACNet Communications, Points List, Schedule Dry

Table 79: BACNet Communications, Points List, Pad Clean					
Variable	Description	Default	R/W	Data Type	BACnet Identifier
PadCleanOverride		-	R/W		BV22
RESERVED	RESERVED FOR "RUN" BIT	-	R		BV23
PadCleanEnable		-	R/W		BV24
PadCleanDays		-	R/W		AV16

Table 79: BACNet Communications, Points List, Pad Clean

Table 80: BACNet Communications, Points List, Drain Dry					
Variable	Description	Default	R/W	Data Type	BACnet Identifier
DrainDryOverride		-	R/W		BV25
RESERVED	RESERVED FOR "RUN" BIT	-	R		BV26
DrainDryEnable		-	R/W		BV27
DrainDryDays		-	R/W		AV17

Table 80: BACNet Communications, Points List, Drain Dry

Appendix A - PLC Hardware Part # 313978

Replacing PLC Battery for units using part number

For units with the PLC shown in **Figure 111**, follow the steps below for battery replacement.



Figure 111

⚠ CAUTION: Battery located in control panel PLC. Risk of explosion resulting in minor or moderate injury or damage to property. Do not recharge or open the battery.



NOTE: Replace battery with R/C (BBCV2), Part. No. CR2032, rated 3V only. Use of another battery may present a risk of fire or explosion. Only use the battery type specified in **Table 81**.



NOTE: Scratches on the control panel PLC motherboard may cause the motherboard to fail. Be careful with the battery replacement lever and be sure to avoid scratching the motherboard.

Battery type	Electrical properties at 68°F (20°C)		Dimensions		
	Nominal voltage	Nominal capacity	Diameter	Height	Weight
CR2032	3.0 V	225 mAh	20.0 mm	3.20 mm	3.1 g

Table 81. Technical Data of PLC Battery

It is recommended to replace the battery every 5 years. The motherboard battery is a CR2032 lithium-metal cell. It is used to supply power to the clock integrated on the motherboard. If the battery is depleted or missing, the date and time are displayed incorrectly. Refer to **Table 81** to for replacement battery information. To change the battery, proceed as follows:

1. Before working on the PLC establish electrostatic discharge (ESD) protection to prevent damage to the device through electrostatic discharge. The replacement of device components without ESD protection can lead to functional impairment and destruction of the device. To gain access to the battery and the storage medium remove the cover on the left-hand side of the device by removing the two Torx TX6 screws as shown in **Figure 112**. With the cover removed the battery and storage media are shown in **Figure 113**.

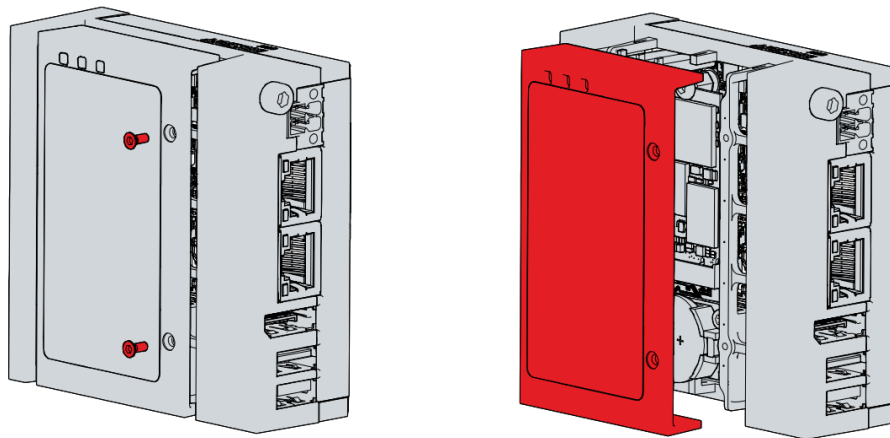

Figure 112. Access to battery and storage media

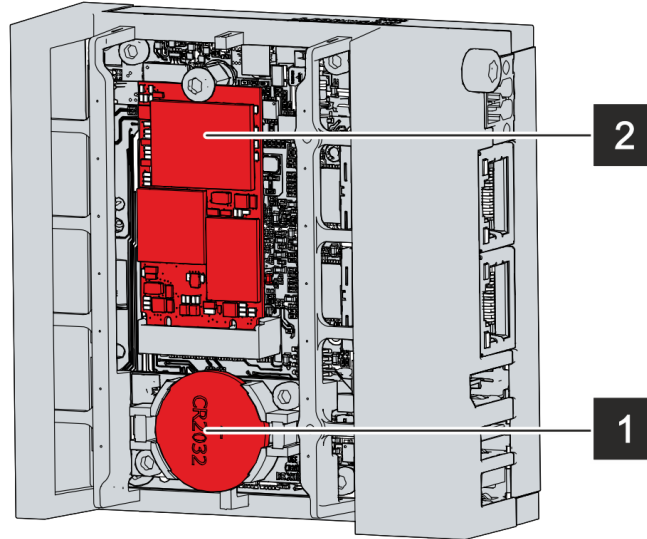

Figure 113. Battery (1) and Storage Media (2)

2. Place a lever made of non-electrically conductive material on the negative pole of the battery holder below the battery.

3. Lift the battery side out of the holder. The battery is now in an inclined position as shown in **Figure 114**.

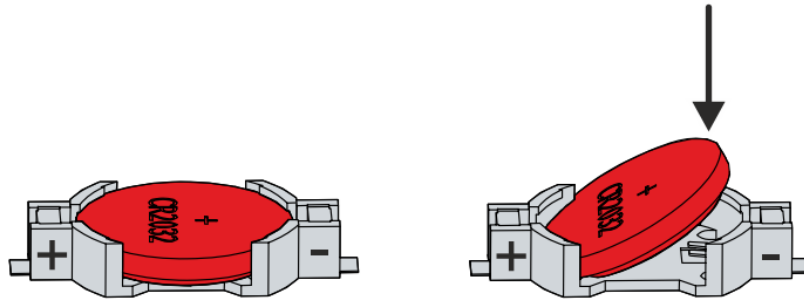

Figure 114. PLC Battery Change

4. Remove the battery completely from the battery holder.
5. Insert the new battery with the correct polarity back into the inclined position on the positive pole of the battery holder. The correct polarity is shown in **Figure 114**.
6. Push the protruding side of the battery into the battery holder as shown in **Figure 114**.
7. To dispose of the battery, remove it, tape off the poles and put it in the battery disposal.

Appendix B– User Interface Part # 313976

Home Menu

The screen or Human Machine Interface (HMI) home menu is shown in **Figure 115**. The home menu displays the leaving fluid temperature or customer input command, leaving fluid temperature setpoint or customer input command, control mode, fan command, and system messages. In addition to all unit and fan alarms, the system messages box can show the messages shown in **Table 82**.

Pressing the “run authorization” button in the upper left-hand corner will toggle the run authorization, turning the unit on or off. Pressing the icons near the bottom of the screen will navigate to their respective menus below.

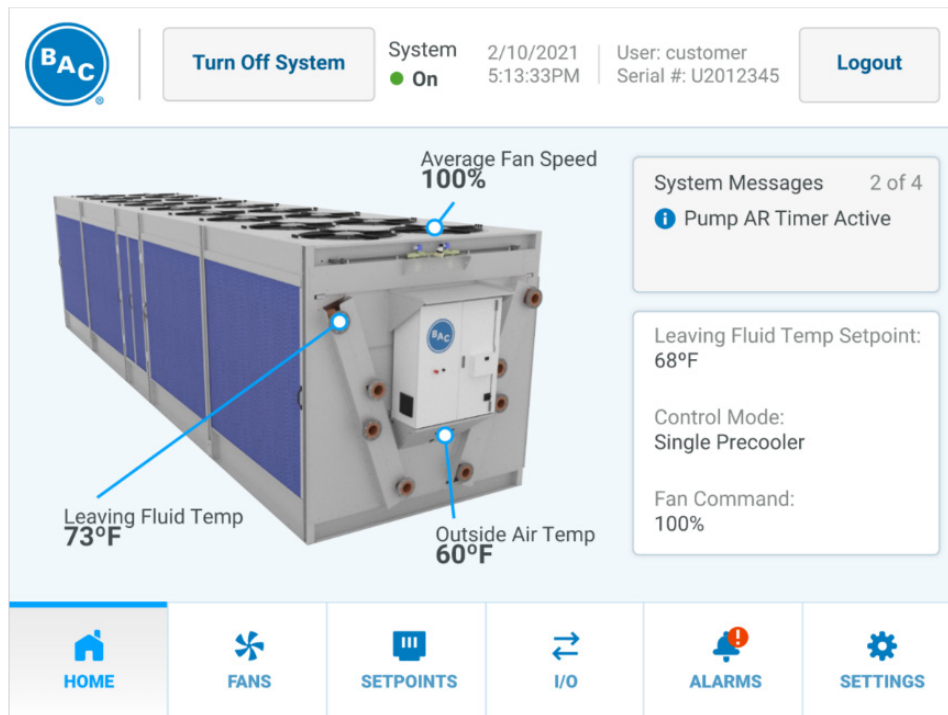

Figure 115. Home Screen

Message Text	Description
Cycle of Concentration Drain	After a set value is reached, the sump is drained to flush out a build-up of excess minerals.
Pump X Anti-Recycle (AR) Timer Active	A timer to prevent excessive on/off cycling of the adiabatic pre-cooler circulation pumps
Water Usage Disabled	Indicates if the unit is restricted from entering adiabatic operation
Night Quiet Mode Active	Indicates if night quiet mode is active
Night Dry Mode Active	Indicates if night dry mode is active
Schedule Dry Mode Active	Indicates if scheduled dry mode is active
Emergency Mode Active	Indicates if the emergency mode is active. During this mode, the fan speed is no longer controlled by the PLC but rather fixed at a predefined level.

Table 82. System Messages

Access Levels

Multiple access levels are present within the software. By pressing the “Logout” button in the upper right corner of the screen as shown in **Figure 115** a user can enter the login screen as shown in **Figure 116**. A password is required to access each level other than user. Access level usernames and passwords are shown in **Table 83**. Pressing the back button in the top right-hand corner will return the user to the home menu.

Figure 116. Login Screen

Access Level	Username	Password
User	n/a	n/a
Technician	Tech	4734

Table 83. Access Levels and Passwords

Overview Menu

The HMI is divided into 4 sections as shown in **Figure 117**.

1. HMI header (top)
2. Main menu (bottom),
3. Sub menu (left)
4. Information section (right)

Menu and sub menu names are shown in **Table 83**.

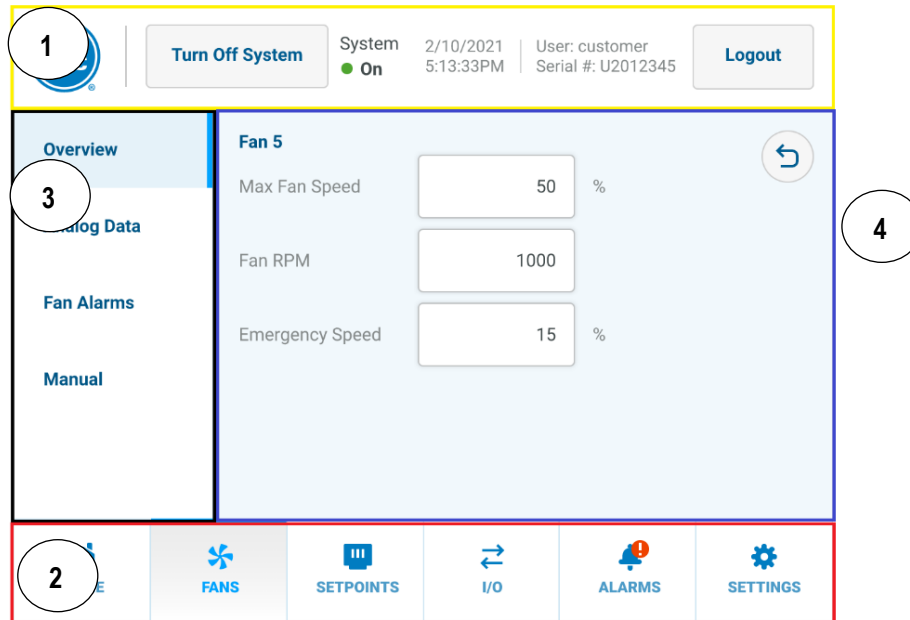

Figure 117. Typical HMI Screen Layout

Main Menu	Sub Menus
Home	
Fans	Overview, Analog Data, Fan Alarms, Manual
Setpoints	Leaving Fluid Control, Basin Water Quality, Load Limiting, Maintenance
Input/Output (I/O)	Temperatures, Make Up, Pumps, Basin Water Level, Starts and Hours, Manual
Alarms	
Settings	Setup, Software Version, Technician

Table 84. Menu and Sub Menu Names

When selecting a menu option that requires data entry, a screen will appear as shown in **Figure 118**. Pressing the “OK” button will modify the writable menu option with the value at the top. Pressing the “Cancel” button returns the user to the previous menu. Pressing the backspace key will delete the one’s place number.

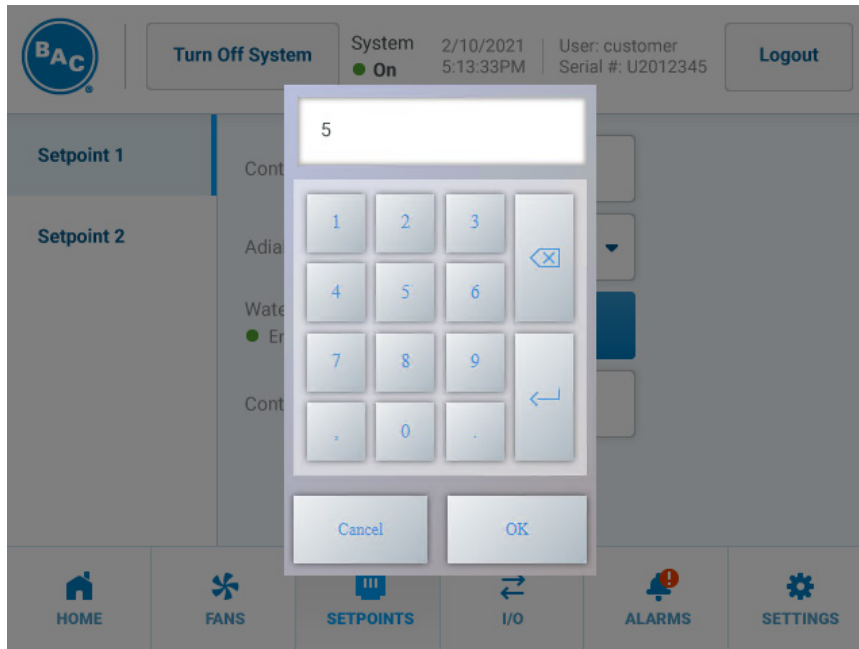

Figure 118. Data Entry Menu

Fan Menu

Figure 119 shows the fan menu. The color of the dot in each fan icon reflects that fan's status: Good (green), Alarm (red), Offline (blue). Fan X's status will show as "Good" when there are no active fan alarms. Fan X's status will show as "Alarm" when any fan alarm is active. Fan X's status will show as Offline when there has not been a response from Fan X in 150 milliseconds.

Pressing on an individual fan takes the user to that fan's specific menu. Pressing on the unit diagram on the left displays the All Fans menu as shown in **Figure 120**. While in the All Fans menu all writable settings will affect all available fans and all readable parameters will be the average reading from of all available fans.

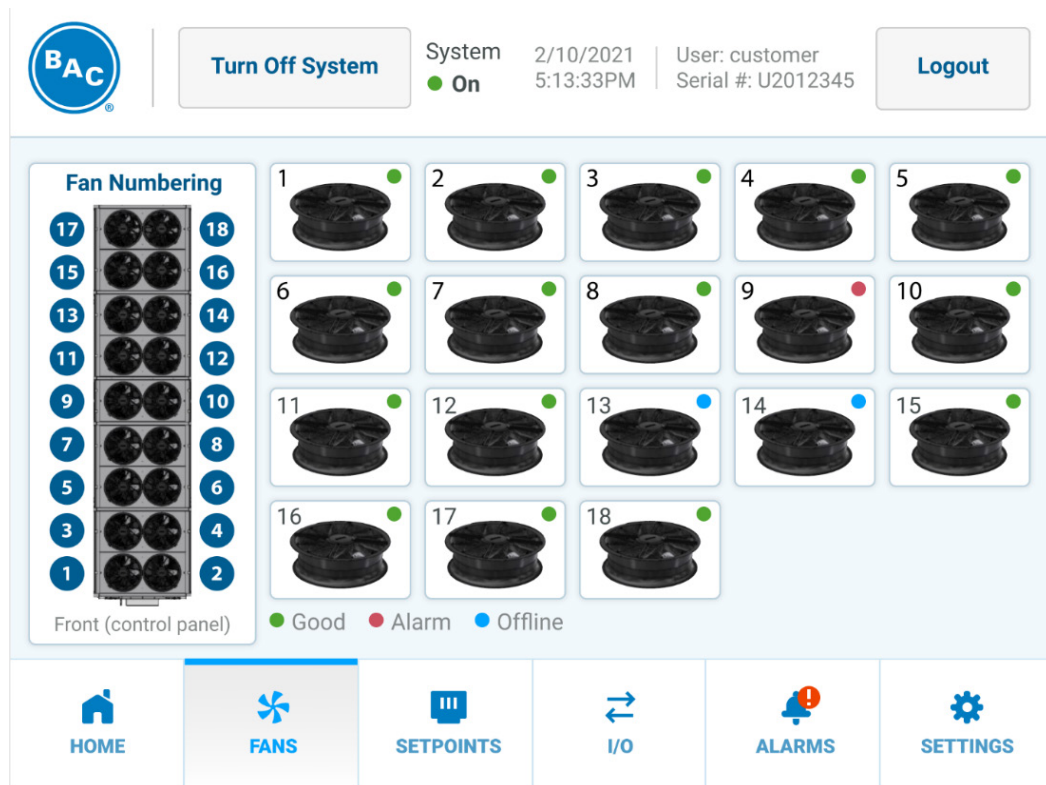

Figure 119. Fan Menu

All Fans Menu - Overview

The screenshot displays the 'All Fans Menu - Overview' interface. At the top left is the BAC logo. To its right is a 'Turn Off System' button. Further right, the system status is shown as 'On' with a green dot, along with the date and time '2/10/2021 5:13:33PM', the user 'customer', and the serial number 'U2012345'. A 'Logout' button is located at the top right. The main content area is titled 'All Fans' and features a left sidebar with 'Overview' selected, and other options 'Analog Data', 'Fan Alarms', and 'Manual'. The main area displays four parameters: 'Max Fan Speed' (50%), 'Fan Command' (1000), 'Average Fan Speed' (975 RPM), and 'Emergency Speed' (15%). A bottom navigation bar includes 'HOME', 'FANS', 'SETPOINTS', 'I/O', 'ALARMS', and 'SETTINGS'.

Figure 120. All Fans Menu, Overview

Parameter	Description
Max Fan Speed	Maximum fan speed for all fans as a % of total fan speed.
Fan Command	Read only
Average Fan Speed	Read only
Emergency Speed	Speed at which all fans will run in case of loss of communication

Table 85. All Fans Menu, Overview Parameters

All Fans Menu – Analog Data

The Analog Data (shown in **Figure 121** and **Figure 122**) displays fan data averaged across all available fans. **Figure 121** is relevant for units with BAC fan part number 251299. **Figure 122** is relevant for units with BAC fan part number 251317. Refer to section **Fan Types** on **Page 33** for more information on how to identify fan type and part number.

The screenshot displays the BAC user interface for the All Fans menu. At the top, there is a BAC logo, a 'Turn Off System' button, and system status information: System is On (indicated by a green dot), the date is 4/2/2022, the time is 10:05:22 AM, the user is Eng H, and the serial number is displayed. A 'Logout' button is also present. The main content area is divided into a sidebar with 'Overview', 'Analog Data', 'Fan Alarms', and 'Manual' sections, and a central 'All Fans' data table. The 'Analog Data' section is currently selected. The data table shows the following values:

Metric	Value	Unit	Metric	Value	Unit
Actual Speed	0	RPM	Current Set Value	0	RPM
DC Link Voltage	0	V	Enable/Disable State	Disabled	
DC Link Current	0.0	A	Current Power	0	W
Module Temp.	0	°C	Operating Hours	0	
Motor Temp.	0	°C			
Current Rotation	Reverse				

The bottom navigation bar includes icons for HOME, FANS (selected), SETPOINT, I/O, ALARMS, and SETTINGS.

Figure 121. All Fans Menu, Analog Data, BAC Fan Part Number 251299

The screenshot shows the BAC Fan control interface. At the top, there is a 'Turn Off System' button, a system status indicator (On), the date and time (2/10/2021 5:13:33PM), user information (User: customer, Serial #: U2012345), and a 'Logout' button. The left sidebar has four menu items: 'Overview', 'Analog Data' (selected), 'Fan Alarms', and 'Manual'. The main content area is titled 'All Fans' and displays a table of fan parameters:

Actual Speed	0	RPM	Speed Setpoint	0	RPM
Motor Current	0	A	Current Direction	FWD	
Motor Power	0	W	Running Hours	0	Hr
Motor Torque	0	Nm	NTC Temp	0	°C
Motor Id Current	0	A			
Motor Iq Current	0	A			
Motor Voltage	0	V			

Below the table are two buttons: '< Previous' and 'Next >'. At the bottom, there is a navigation bar with six icons: 'HOME', 'FANS' (selected), 'SETPOINTS', 'I/O', 'ALARMS', and 'SETTINGS'.

Figure 122. All Fans Menu, Analog Data, BAC Fan Part Number 251317

All Fans Menu – Alarms

Fan Alarms (shown in **Figure 123** and **Figure 124**) displays all possible fan alarms. A green dot indicates the alarm is not active. A red dot indicates the alarm is active. Pressing the “Previous” or “Next” buttons allow the user to view an additional page of fan alarms. **Figure 123** is relevant for units with BAC fan part number 251299. **Figure 124** is relevant for units with BAC fan part number 251317. Refer to section **Fan Types** on **Page 33** for more information on how to identify fan type and part number.

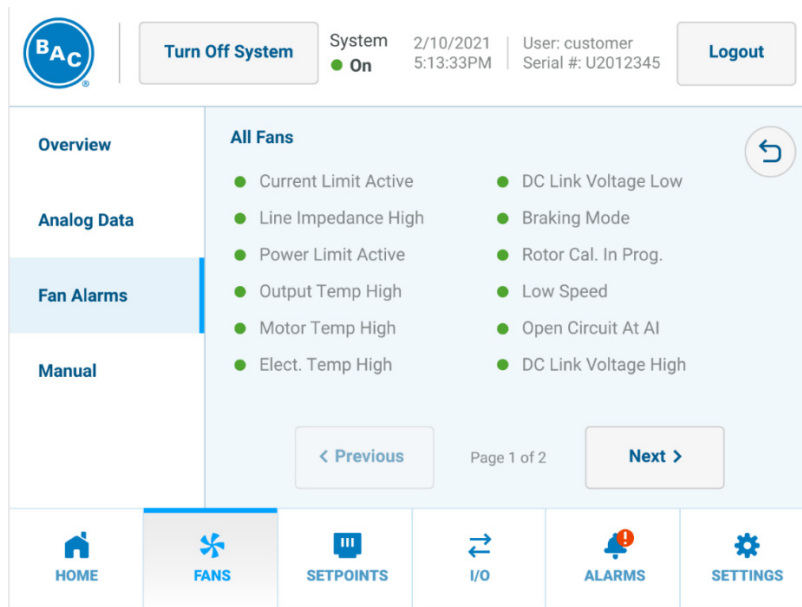

Figure 123. All Fans Menu, Fan Alarms, BAC Fan Part Number 251299

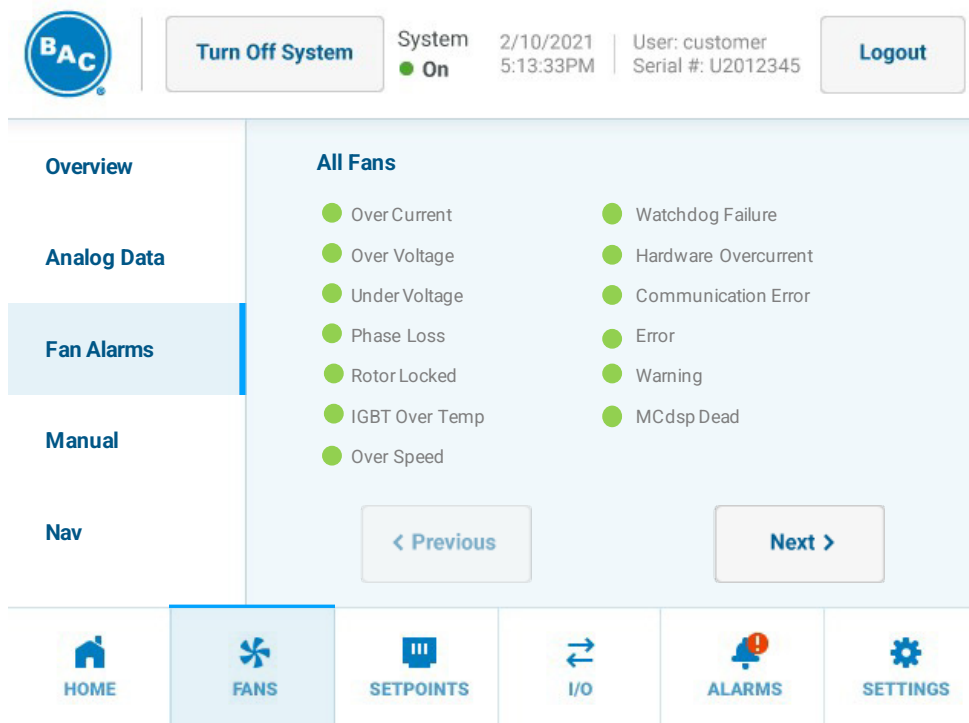

Figure 124. All Fans Menu, Fan Alarms, BAC Fan Part Number 251317

The Manual menu shown in **Figure 125** is only visible with Technician access level. Refer to **Table 83. Access Levels and Passwords** on **Page 154**. Setting the All Fans Manual Mode to Enable transitions the control state to Manual. The Manual menu allows a user to override the fan speed, fan rotation direction, and start, stop, or reset all fans.

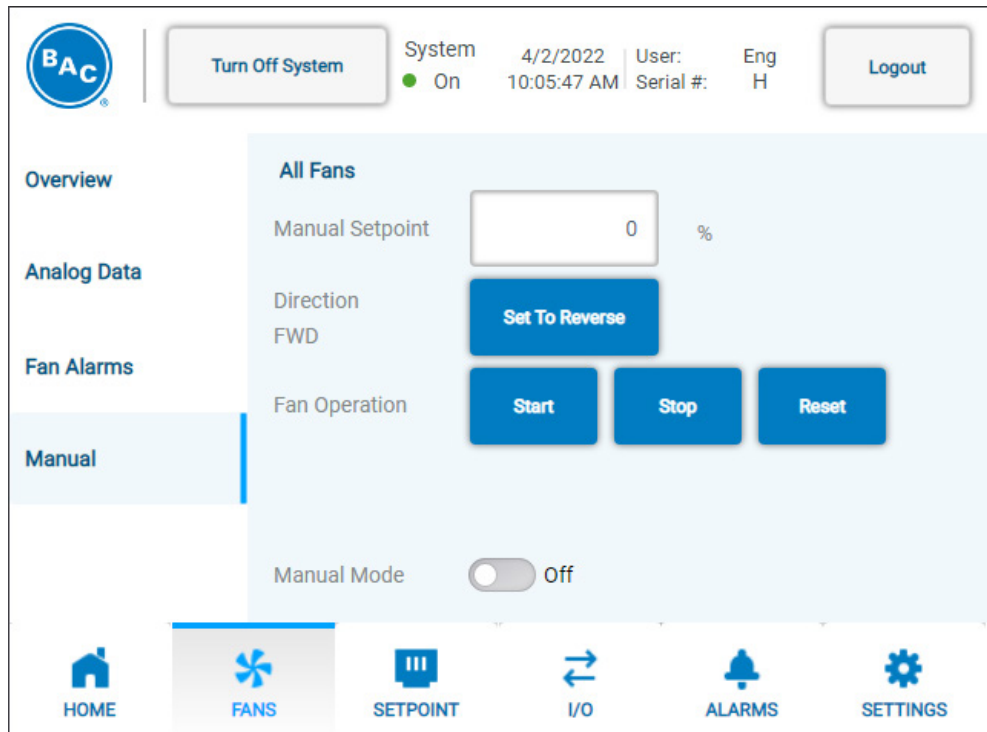

Figure 125. All Fans Menu, Manual, BAC Fan Part Number 251299

Fan X Menu

Pressing on Fan X in the Fan Overview menu shown in **Figure 120** brings the user to the Fan X Overview tab shown in **Figure 126**. Analog Data menu reflects **Figure 121** or **Figure 122** and Fan Alarms menu reflects **Figure 123** or **Figure 124**, however information displayed on these menus is per fan.

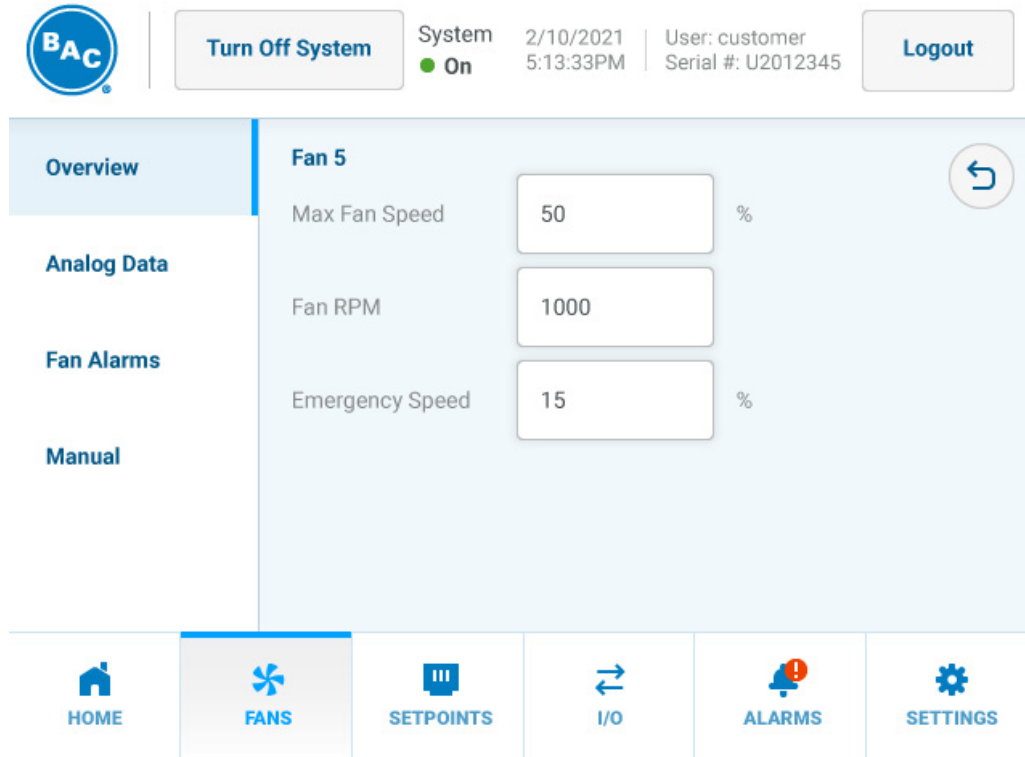

Figure 126. Fan X Menu, Overview

The Manual menu shown in **Figure 127** is only visible with Technician access level. Refer to **Table 83. Access Levels and Passwords** on **Page 154**. Setting the Fan X Manual Mode to Enable will not transition the control state to Manual. The Manual menu allows a user to override the fan speed, fan rotation direction, start, stop or reset a fan as well as read out the fan Modbus address.

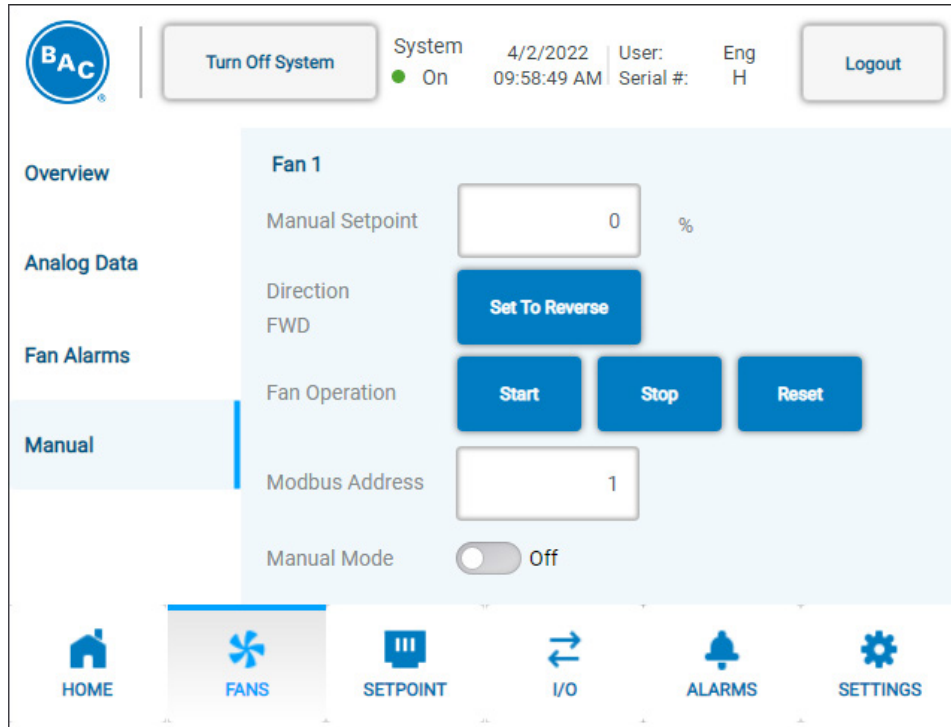

Figure 127. Fan X Menu, Manual

Setpoints

Leaving Fluid Control & Customer Input Control Menu

With the parameters that can be set in this menu, the user can finetune the behavior of the unit. The Leaving Fluid Control tab shown in **Figure 128** is only visible if the Control Type is Leaving Fluid Control. The Customer Input Control tab shown in **Figure 129** is only visible if the Control Type is Customer Input. The Customer Input Control mode allows the user to provide an analog input signal to control the unit's capacity between 0% and 100%. **Table 86** lists the parameters available in Setpoints menu, Leaving Fluid Control and Customer Input Control.

Parameter	Value	Unit
Operating Mode	Energy Saver	
Leaving Fluid Temp Setpoint	38	°C
Control Range	38	°C
Adiabatic Switchpoint	38	°C
Run Authorization Type	Digital Input	

Figure 128. Setpoints Menu, Leaving Fluid Control

The screenshot displays the BAC (Building Automation Control) system interface. At the top left is the BAC logo. To its right is a 'Turn Off System' button. Further right, system status is shown: 'System' with a green dot and 'On' indicator, the date '2/10/2021' and time '5:13:33PM', and user information 'User: customer' and 'Serial #: U2012345'. A 'Logout' button is located at the top right.

The main interface is divided into a left sidebar menu and a main content area. The sidebar menu includes 'Customer Input Control' (highlighted), 'Basin Water Quality', 'Load Limiting', and 'Maintenance'. The main content area contains four rows of controls:

- Operating Mode:** A dropdown menu currently set to 'Energy Saver'.
- Signal Type:** A dropdown menu currently set to 'Digital Input', followed by a temperature unit '°C'.
- Adiabatic Switchpoint:** A text input field containing the value '38', followed by a temperature unit '°C'.
- Run Authorization Type:** A dropdown menu currently set to 'Digital Input'.

At the bottom of the interface is a navigation bar with six icons and labels: 'HOME', 'FANS', 'SETPOINTS' (highlighted), 'I/O', 'ALARMS', and 'SETTINGS'.

Figure 129. Setpoints Menu, Customer Input Control

Parameter	Description
Operating Mode: Default	Utilizes factory set operating variables that provides a balance of water and energy savings. See Table 87 . Operating Mode Parameters for more information.
Operating Mode: Energy Saver	Energy Saver mode will enter adiabatic operation more quickly than Default or Water Saver Operating Modes resulting in lower fan power energy consumption. See Table 87 . Operating Mode Parameters for more information.
Operating Mode: Water Saver	Water Saver mode will stay in dry operation longer than Default or Energy Saver Operating Modes resulting in lower water consumption. See Table 87 . Operating Mode Parameters for more information.
Signal Type	Defines the type of input signal. This can be set to either 4-20mA, 0-10V, 10-0V or BMS 0-100%. The current signal is supplied to input card EL3014 channel 2 or contacts X7:27 and X7:28. The voltage signal is supplied to input card EL3174 channel 1 or contacts X7:17 and X7:18. The BMS signal refers to the “CIFanCMD” variable in Table 151 .
Leaving Fluid Temp Setpoint	Set-point for the fluid outlet temperature
Control Range	Allowed offset in leaving fluid temperature set point before changing stages/operating modes. For example, allows leaving fluid temperature to rise above leaving fluid temp setpoint by this control range before changing to adiabatic mode.
Adiabatic Switchpoint	Ambient temperature at which adiabatic operation becomes possible. See Adiabatic Switchpoint on Page 14 for more details.
Run Authorization Type	Source signal to switch the unit between stand-by and active. This can be set to either HMI, digital input or BMS. HMI refers to the button on the top left of the screen, digital input refers to input card EL1008 channel 6 or contacts X5:7 and X5:8 on the terminal strip, BMS refers to the “BMSrunEn” variable in Table 151 . The HMI button is always taken into account to enable the unit to run (also when the type is set to digital input or BMS).

Table 86. Setpoints Menu, Leaving Fluid/Customer Input Control Parameters

Parameter	Operating Mode		
	Default	Energy Saver	Water Saver
Control Range	3.6°F (2.0°C)	0.9°F (0.5°C)	10.0°F (5.5°C)
Adiabatic Switchpoint	X	lowers current setpoint by 10.0°F (5.5°C)	X
Stage Timer	120 seconds	60 seconds	300 seconds

Table 87. Operating Mode Parameters

Basin Water Quality Menu

The Basin Water Quality menu shown in **Figure 130** and **Figure 131** allows a user to adjust parameters shown in **Table 15**. Setpoints Menu, Basin Water Quality Parameters

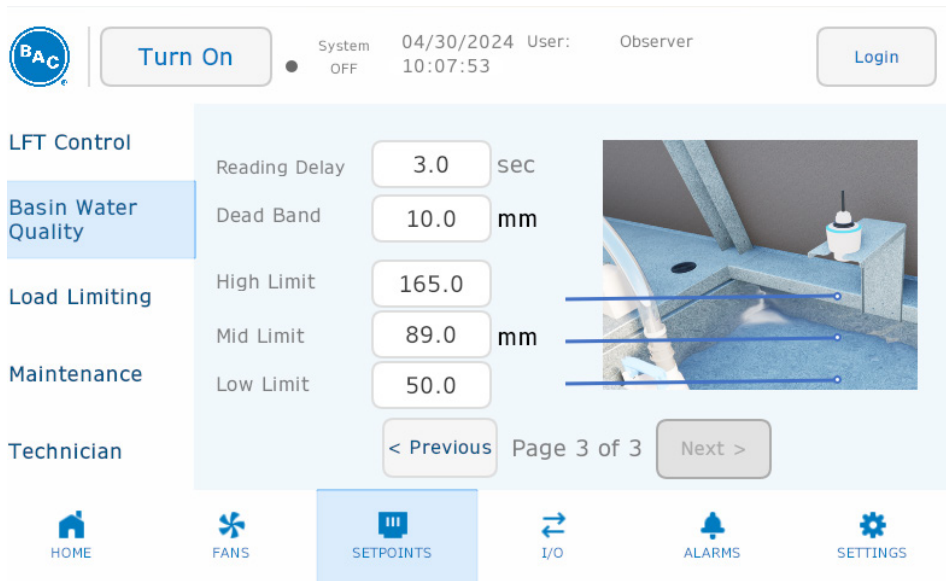

Figure 130

Figure 130. Setpoints Menu, Basin Water Quality Page 1 of 2

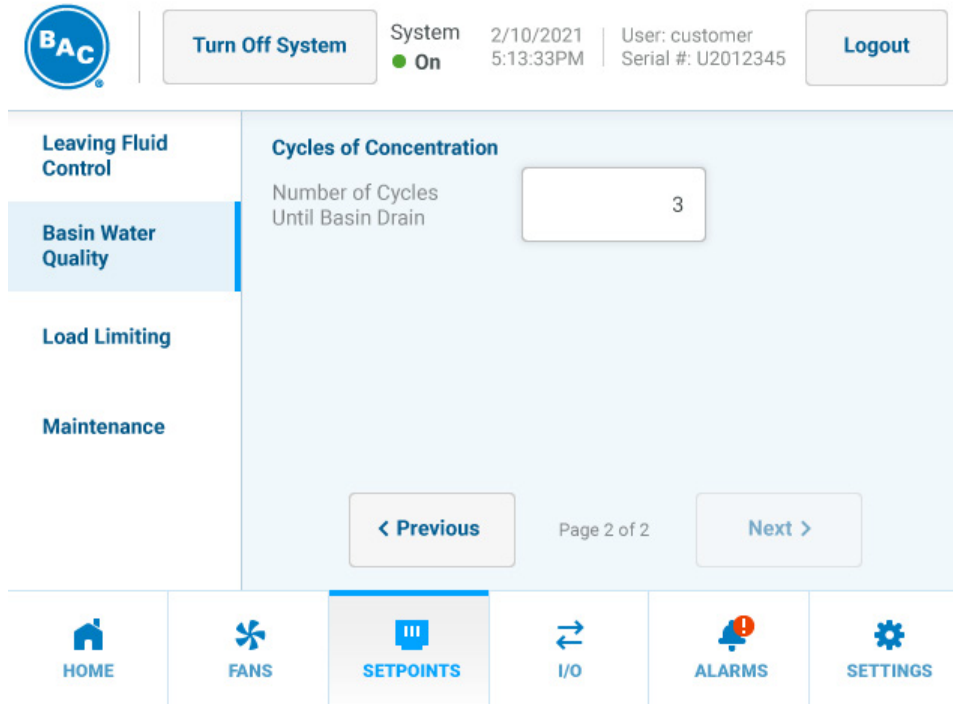

Figure 131. Setpoints Menu, Basin Water Quality Page 2 of 2

Parameter	Description
Disable Water Usage	Manually disable water usage (prevent adiabatic operation)
Basin Retention Time	Time after switch to dry operation before fully draining the water in the basin (sump). Low limit 1 hour, high limit 72 hours, default 24 hours.
Precooler X Run Hours	Number of adiabatic operating hours on each pre-cooler air inlet face
Number of Cycles Until Basin Drain	Number of cycles of concentration till basin (sump) drains and is replaced with make-up water. A cycle of concentration is defined as the basin water level starting at the High Level Float, down to the Mid Level Float, then back to the High Level Float. The loss of basin water is due to evaporation on the adiabatic pads. Low limit 3, high limit 10, default 3.

Table 88. Setpoints Menu, Basin Water Quality Parameters

Load Limiting Menu

Refer to **Load Limiting Modes** on **Page 15** for more information. The Load Limiting menu includes:

- Night Quiet load limiting mode shown in **Figure 132** and **Figure 133** with parameters listed in **Table 89**.

- Night Dry load limiting mode shown in **Figure 134** and **Figure 135** with parameters listed in **Table 90**.
- Schedule Dry load limiting mode shown in **Figure 136** and **Figure 137** with parameters listed in **Table 91**.

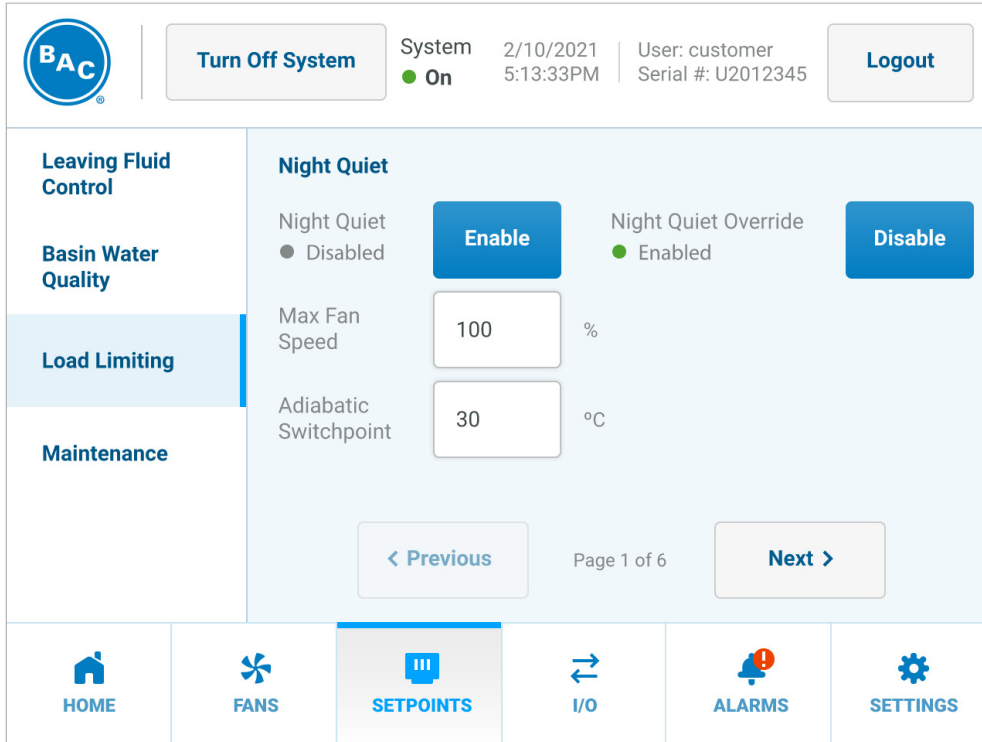



Figure 132. Setpoints Menu, Load Limiting Page 1 of 6



Turn Off System

System ● On

2/10/2021
5:13:33PM

User: customer
Serial #: U2012345

Logout

Leaving Fluid Control

Basin Water Quality

Load Limiting

Maintenance

Night Quiet Schedule

Sun to Mon:	21:00 - 06:00	Sun to Mon
Mon to Tue:	21:00 - 06:00	
Tue to Wed:	21:00 - 06:00	
Wed to Thu:	21:00 - 06:00	
Thu to Fri:	21:00 - 06:00	
Fri to Sat:	21:00 - 06:00	
Sat to Sun:	21:00 - 06:00	

21:00

-

06:00

Update Schedule

< Previous

Page 2 of 6

Next >

HOME

FANS

SETPOINTS

I/O

ALARMS



SETTINGS

Figure 133. Setpoints Menu, Load Limiting Pag

Parameter	Description
Night Quiet Enable/Disable	Allows use to either enable or disable the feature. If enabled, the “max fan speed” and “adiabatic switchpoint” parameters will become active during the times set in the schedule shown in Figure 133 .
Max Fan Speed	Maximum fan speed that needs to be observed when “night quiet” mode is active
Adiabatic Switchpoint	Reduced ambient temperature at which adiabatic operation becomes possible. This second (reduced versus the standard) adiabatic switchpoint allows adiabatic operation at lower ambient temperatures in order to make up for the lower available thermal performance due to the lower fan speed.
Night Quiet Override	If enabled, the “max fan speed” and “adiabatic switchpoint” parameters will become active regardless of the schedule shown in Figure 133. In addition to the on-screen button, the override can also be enabled with the “NightQuietOverride” variable in Table 151 .
Night Quiet Schedule	The schedule defines a start time on one day and a stop time on the next day. All times are in 24-hour format.

Table 89. Setpoints Menu, Load Limiting Night Quiet Parameters

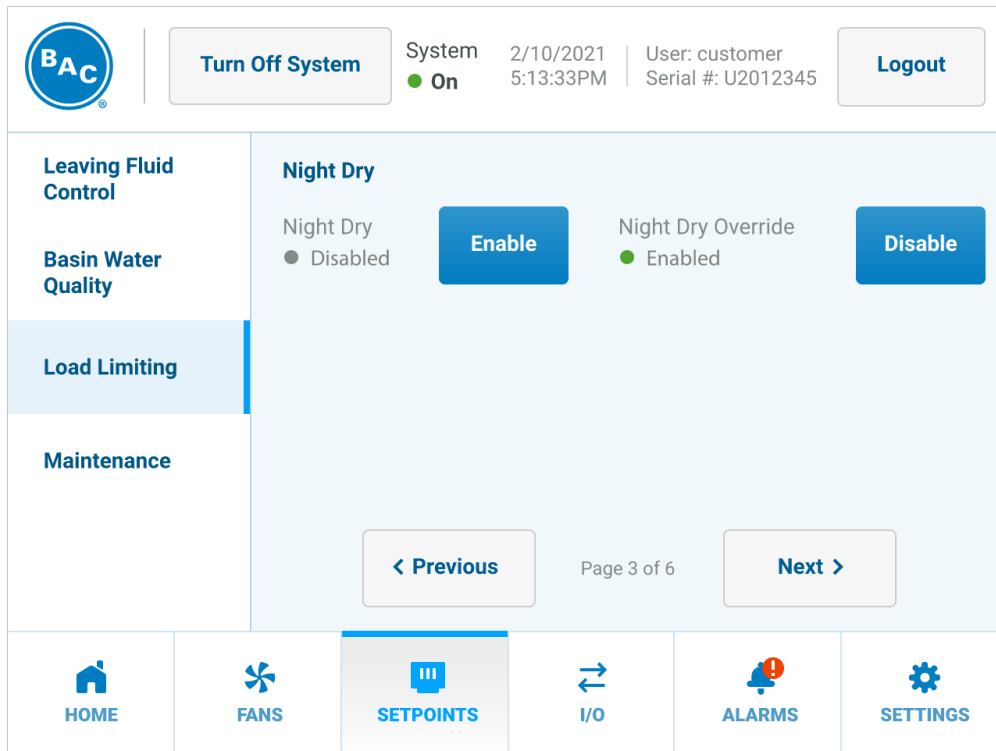

Figure 134. Setpoints Menu, Load Limiting Page 3 of 6

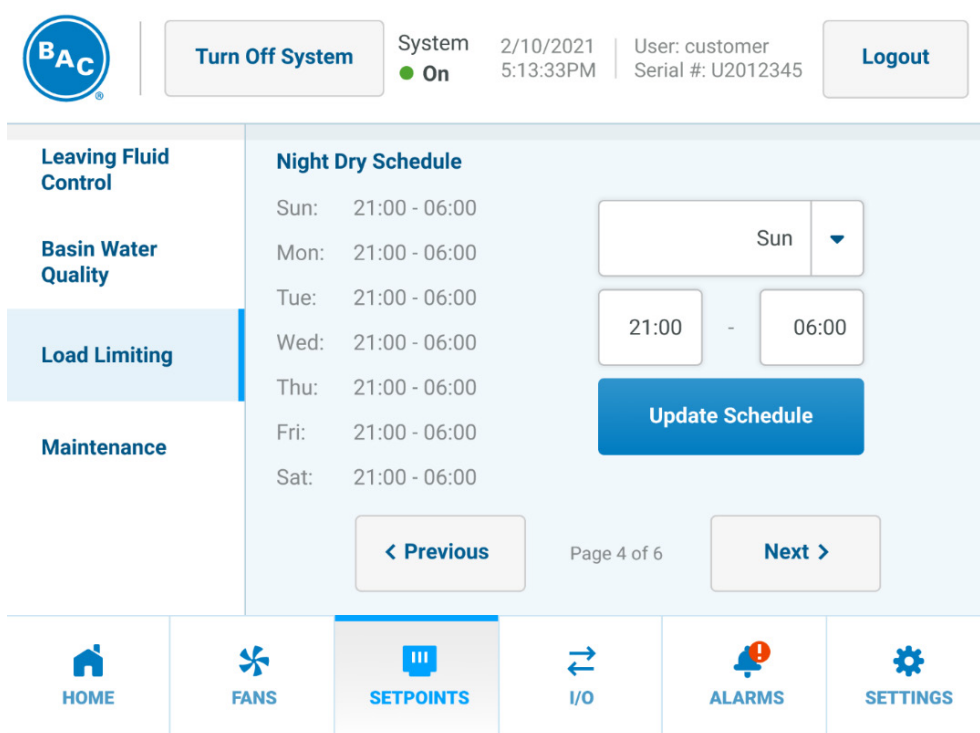

Figure 135. Setpoints Menu, Load Limiting Page 4 of 6

Parameter	Description
Night Dry Enable/Disable	Allows user to either enable or disable the feature. If enabled, no water will be used during the times set in the schedule shown in Figure 135 .
Night Dry Override	If enabled, no water will be used regardless of the schedule shown in Figure 135 . In addition to the on-screen button, the override can also be enabled with the “NightDryOverride” variable in Table 151 .
Night Dry Schedule	The schedule defines a start time on one day and a stop time on the next day. All times are in 24-hour format.

Table 90. Setpoints Menu, Load Limiting Night Dry Parameters

Figure 136. Setpoints Menu, Load Limiting Page 5 of 6

Figure 137. Setpoints Menu, Load Limiting Page 6 of 6

Parameter	Description
Schedule Dry Enable/Disable	Allows user to either enable or disable the feature. If enabled, no water will be used during the times set in the schedule shown in Figure 137 .
Schedule Dry Override	If enabled, no water will be used regardless of the schedule shown in Figure 137 . In addition to the on-screen button, the override can also be enabled with the “ScheduleDryOverride” variable in Table 151 .
Schedule Dry Schedule	The schedule defines a start time on one day and a stop time on the same day. All times are in 24-hour format.

Table 91. Setpoints Menu, Load Limiting Schedule Dry Parameters

Maintenance Menu

Refer to **Maintenance Modes** on **Page 15** for more information. The Maintenance menu includes

- Coil Clean maintenance mode shown in **Figure 138** with parameters listed in **Table 92**.
- Pad Clean maintenance mode shown in **Figure 139** with parameters listed in **Table 93**.
- Complete Drain and Dry maintenance mode shown in **Figure 140** with parameters listed in **Table 94**.

Figure 138. Setpoints Menu, Maintenance Page 1 of 3

Parameter	Description
Coil Clean Enable/Disable	Allows user to either enable or disable the feature. If enabled, the fans will do a daily cycle at a 100% fan speed in reverse direction at the time programmed.
Cleaning High Limit Temp	Maximum ambient temperature at which the coil cleaning cycle can start. Because the fans run in reverse, they will push warm ambient air over the coils in summer.
Cleaning Low Limit Temp	Minimum ambient temperature at which the coil cleaning cycle can start. Because the fans run at maximum fan speed, there would be an undercooling and/or coil freezing risk if allowed to become too low.
Coil Clean Duration	Time in seconds the coil cleaning cycle lasts
Time Between Coil Clean	Number of hours between coil cleaning cycles
Coil Clean Start Time	Time of the day when the coil cleaning cycle will start

Table 92. Setpoints Menu, Coil Clean Parameters

Figure 139. Setpoints Menu, Maintenance Page 2 of 3

Parameter	Description
Pad Clean Enable/Disable	Allows user to either enable or disable the feature. If enabled, the pads will be rinsed at the time programmed.
Pad Clean Duration	Time in seconds the pad cleaning cycle lasts.
Time Between Pad Cleans	Number of hours between pad cleaning cycles
Pad Clean Start Time	Time of the day when the pad cleaning cycle will start, preferably set in the afternoon to take advantage of the increased cooling effect during the warmest period of the day.

Table 93. Setpoints Menu, Pad Clean Parameters

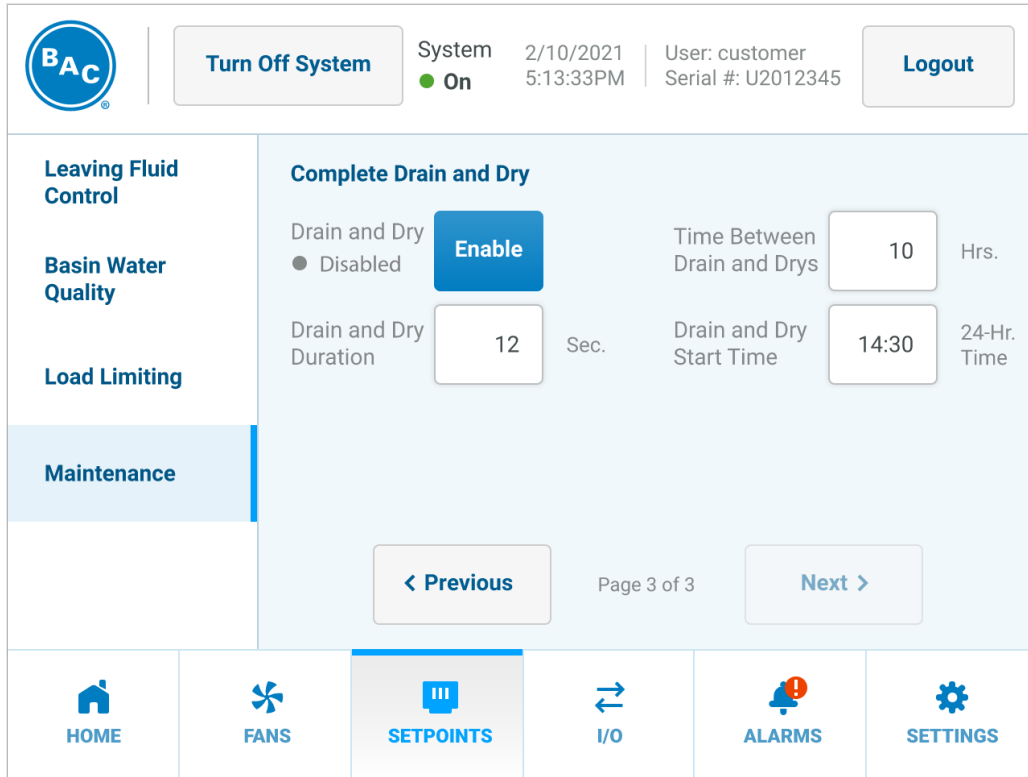

Figure 140. Setpoints Menu, Maintenance Page 3 of 3

Parameter	Description
Drain and Dry Enable/Disable	Allows user to either enable or disable the feature. If enabled, the fans will do a daily cycle at a 100% fan speed at the time programmed.
Drain and Dry Duration	Time in seconds the drain and dry cycle lasts.
Time Between Drain and Dry	Number of hours between pad drain and dry cycles.
Drain and Dry Start Time	Time of the day when the drain and dry cycle will start.

Table 94. Setpoints Menu, Complete Drain and Dry Parameters

Technician Menu

The Technician menu shown in **Figure 141** is only visible with Technician access level. Refer to **Table 83. Access Levels and Passwords** on **Page 154**. Technician menu parameters are shown in **Table 95**. Note that changing the PI (proportional and integration) parameters or stage time may result in a hunting phenomenon.

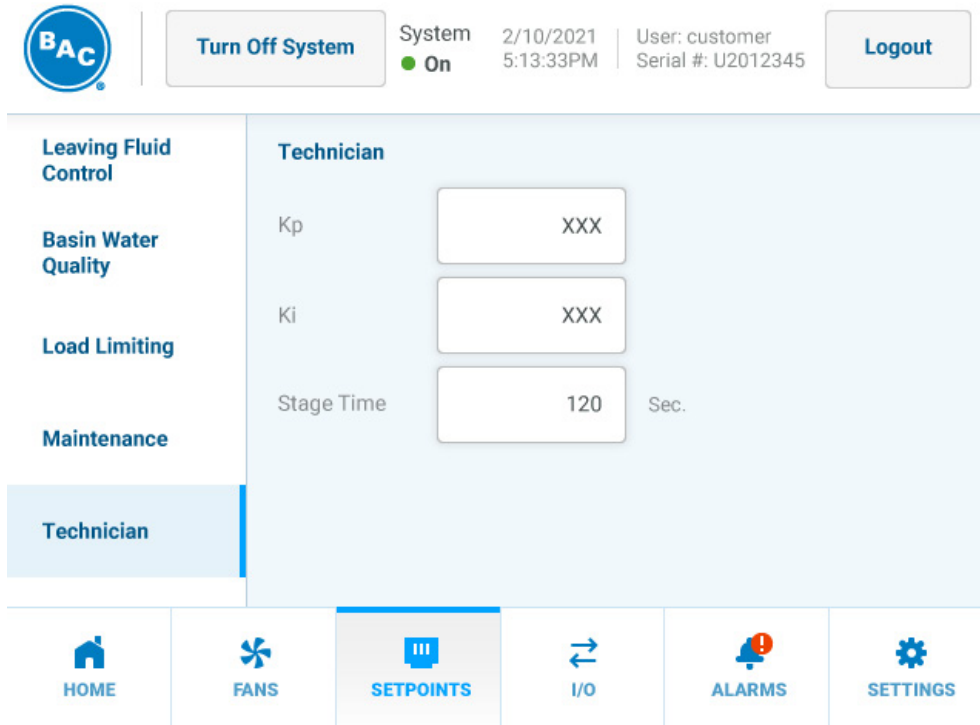

Figure 141. Setpoints Menu, Technician

Parameter	Description
Kp	Set the value for the proportional band of the fan speed PI controller
Ki	Set the value for the integration time of the fan speed PI controller
Stage Time	Time to switch between different operating modes

Table 95. Setpoints Menu Technician Parameters

Input & Output

With the parameters that can be set in this menu, the user can view the status of all available inputs and outputs. In addition, some output signals can be forced in a certain position to overrule the default programming.

Temperatures Menu

Temperature menu is shown in **Figure 142** and **Figure 143** with parameters listed in **Table 96**. **Figure 143** only appears if the Precool Temp Sensor option is provided on the unit.



Figure 142. I/O Menu, Temperature Page 1 of 2

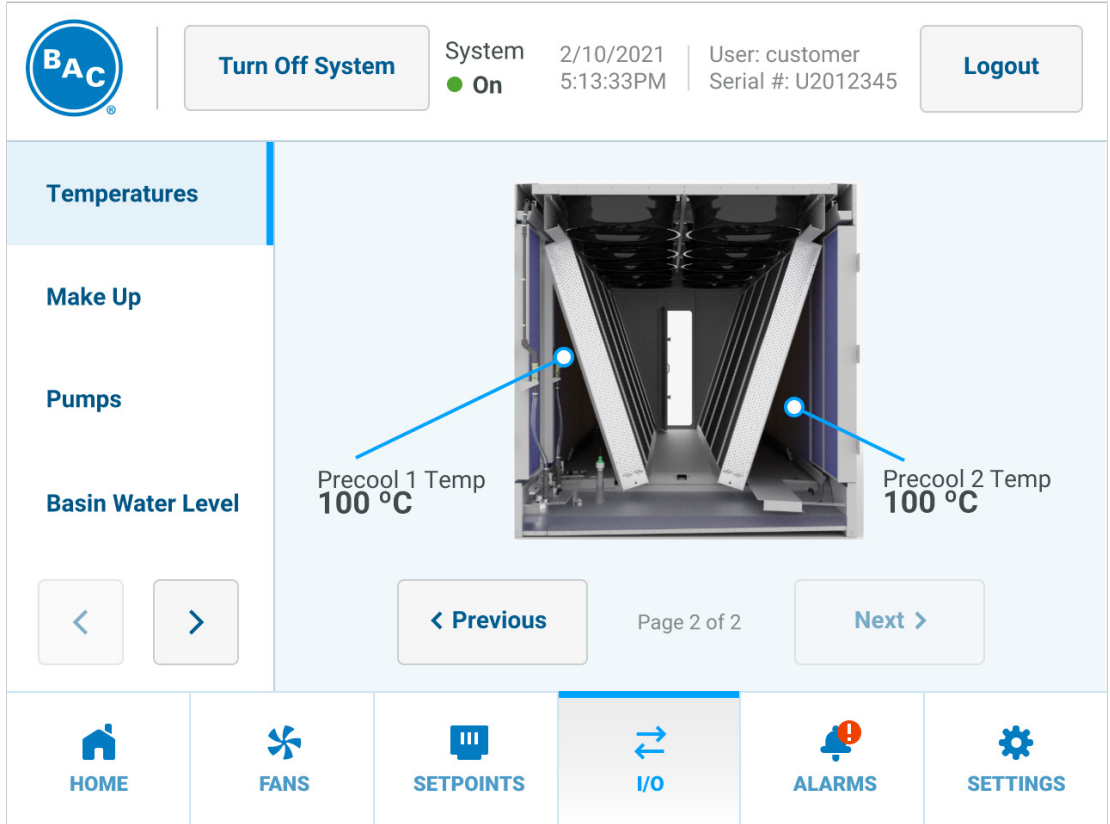

Figure 143. I/O Menu, Temperature Page 2 of 2

Parameter	Description
Leaving Fluid Temp	Process fluid temperature
Outside Air Temp	Ambient dry bulb temperature
Precool X Temp	Depressed dry bulb temperature behind the adiabatic pre-cooler section.

Table 96. I/O Menu, Temperature Parameters

Make Up Menu

Make Up menu is shown in **Figure 144** with parameters listed in **Table 97**.

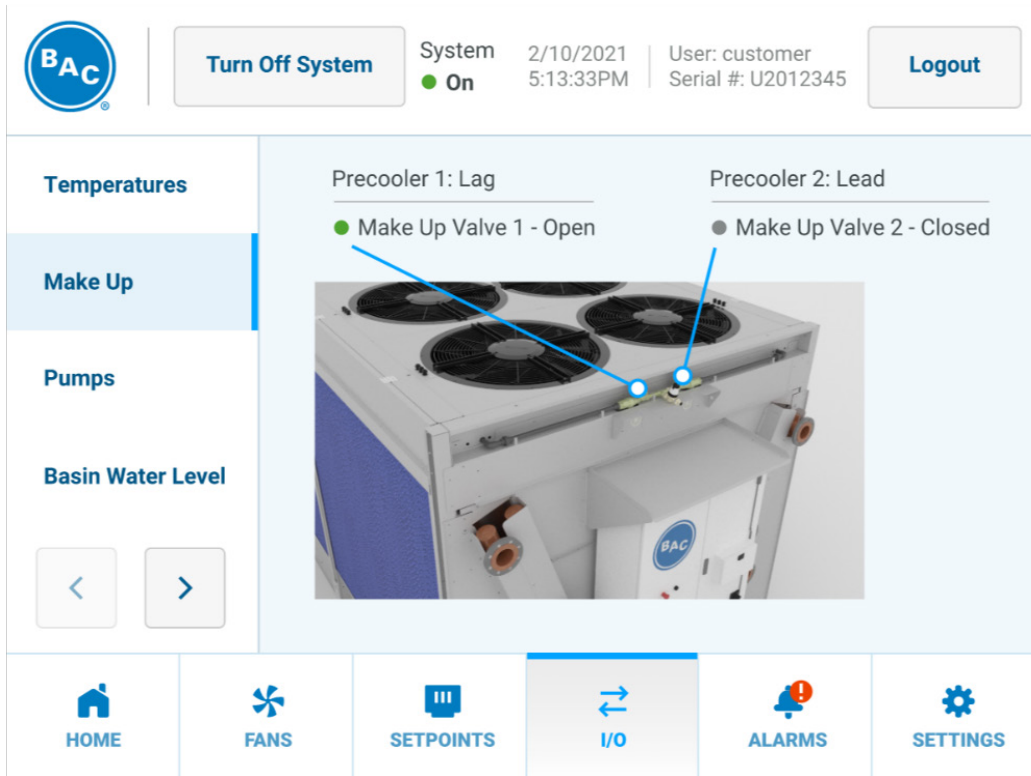

Figure 144. I/O Menu, Make Up

Parameter	Description
Precooler X	Indication if the makeup valves are open or closed.

Table 97. I/O Menu, Make Up Parameters

Pumps Menu

Pumps menu is shown in **Figure 145** with parameters listed in **Table 98**.

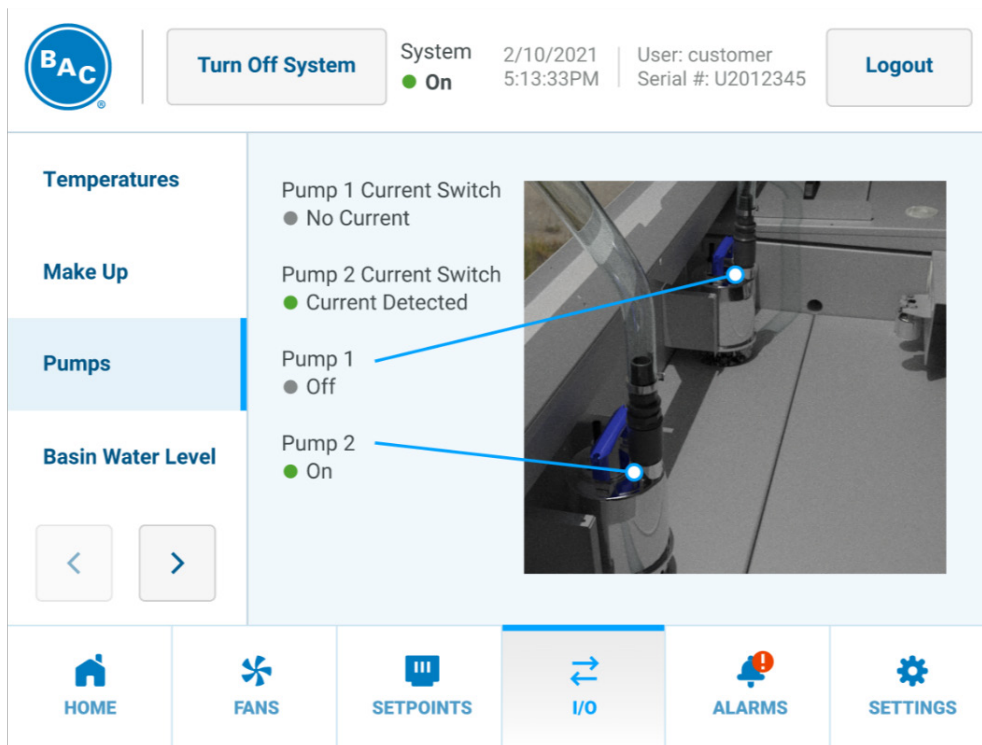

Figure 145. I/O Menu, Pumps

Parameter	Description
Pump X Current Switch	Indication if the pump is properly running (current detected) or not (no current). The current switch gives an indication of electrical current.
Pump X	Indication if the pump is On or Off.

Table 98. I/O Menu, Pumps Parameters

Basin Water Level Menu

Basin Water Level menu is shown in **Figure 146** with parameters listed in **Table 99**.

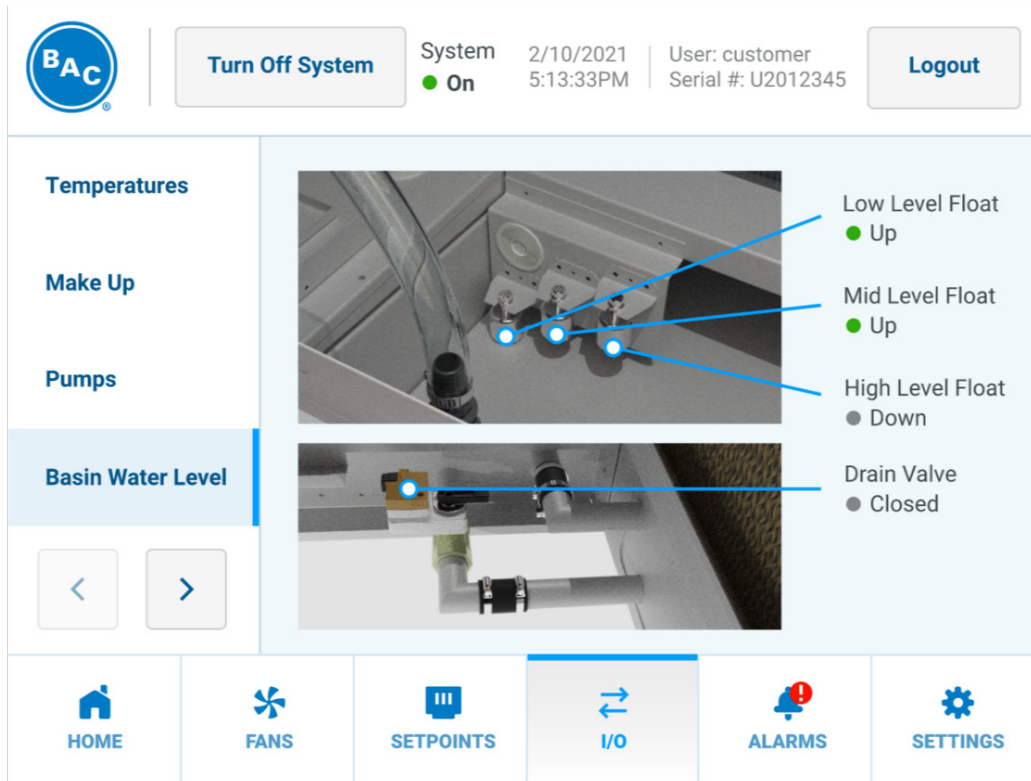

Figure 146. I/O Menu, Basin Water Level

Parameter	Description
Low/Mid/High Level Float	Status indication of the sump water level float switch. Green dot with description "Up" indicates water level is at or above specified level. Gray dot with description "Down" indicated water level is at or below specified level.
Drain Valve	Indication if the valve is open (water draining from the sump) or closed (keeping water in the sump)

Table 99. I/O Menu, Basin Water Level Parameters

Starts and Hours Menu

The Starts and Hours menu is shown in **Figure 147** through **Figure 149** with parameters listed in **Table 100**. Here, the number of starts and operating hours can be reviewed. Pressing the “Reset” button resets the starts and hours for the corresponding device. A reset can only be done with Technician level access. Refer to **Table 83**. Access Levels and Passwords on **Page 154**.

The screenshot displays the BAC I/O menu interface. At the top left is the BAC logo. To its right is a 'Turn Off System' button. Further right, system status is shown as 'System On' with a green dot. The date and time are '2/10/2021 5:13:33PM'. User information includes 'User: customer' and 'Serial #: U2012345'. A 'Logout' button is in the top right corner.

The main content area is titled 'Starts and Hours' and contains a table with the following data:

Device	Starts	Hours	Action
Precooler 1	100	150	Reset
Precooler 2	100	150	Reset
MUP1	100	150	Reset

Navigation elements include a 'Manual' link on the left, left and right arrow buttons, and 'Previous' and 'Next' buttons at the bottom of the table area. The page indicator shows 'Page 1 of 3'. A bottom navigation bar contains icons for HOME, FANS, SETPOINTS, I/O (highlighted), ALARMS, and SETTINGS.

Figure 147. I/O Menu, Starts and Hours Page 1 of 3

BAC | **Turn Off System** | System **On** | 2/10/2021 5:13:33PM | User: customer Serial #: U2012345 | **Logout**

Component	Starts	Hours	Action
MUP2	100	150	Reset
Drain Valve	100	150	Reset
Pump 1	100	150	Reset

Manual

< > < Previous Page 2 of 3 Next >

HOME FANS SETPOINTS **I/O** ALARMS SETTINGS

Figure 148. I/O Menu, Starts and Hours Page 2 of 3

BAC | **Turn Off System** | System **On** | 2/10/2021 5:13:33PM | User: customer Serial #: U2012345 | **Logout**

Component	Starts	Hours	Action
Pump 2	100	150	Reset

Manual

< > < Previous Page 3 of 3 Next >

HOME FANS SETPOINTS **I/O** ALARMS SETTINGS

Figure 149. I/O Menu, Starts and Hours Page 3 of 3

Parameter	Description
Precooler X	Number of starts and operating hours the unit is in adiabatic operation.
MUPX	Number of starts and operating hours for each make up valve.
Drain Valve	Number of starts and operating hours for drain valve.
Pump X	Number of starts and operating hours for each pump.

Table 100. I/O Menu, Starts and Hours Parameters

Manual Menu

The Manual menu will display only with Technician level access. Refer to **Table 83. Access Levels and Passwords** on **Page 154**. The Manual menu is shown in **Figure 150** and **Figure 151** with parameters listed in **Table 101**. In this menu, the position of a number of digital outputs can be overruled. Each digital output manual mode must be set to “On” in order to override the applicable value.

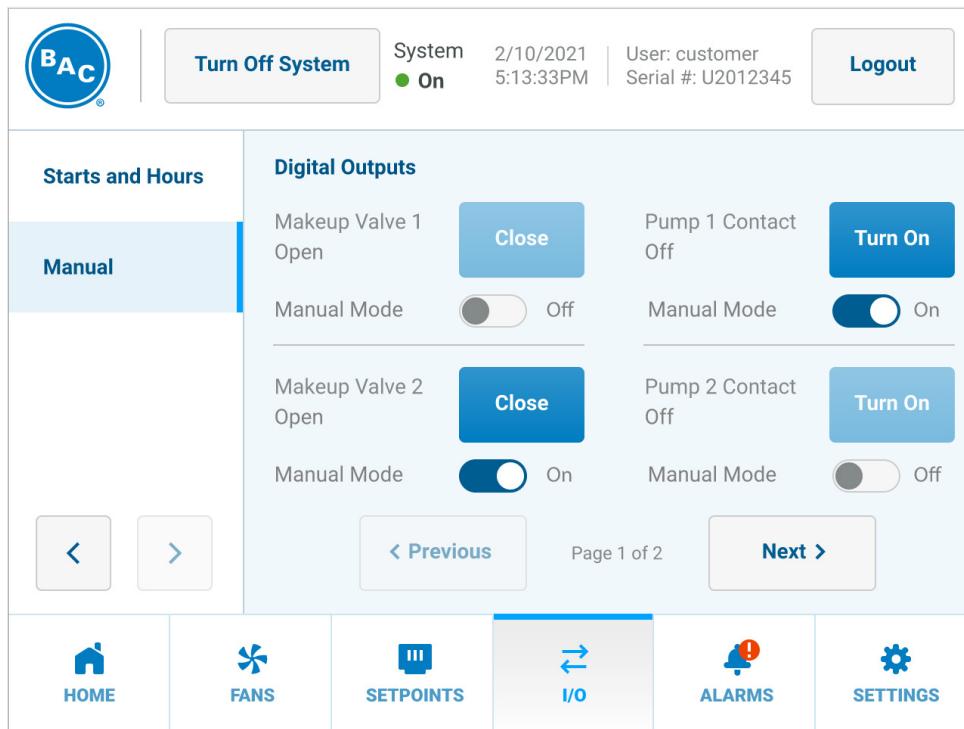

Figure 150. I/O Menu, Manual Page 1 of 2

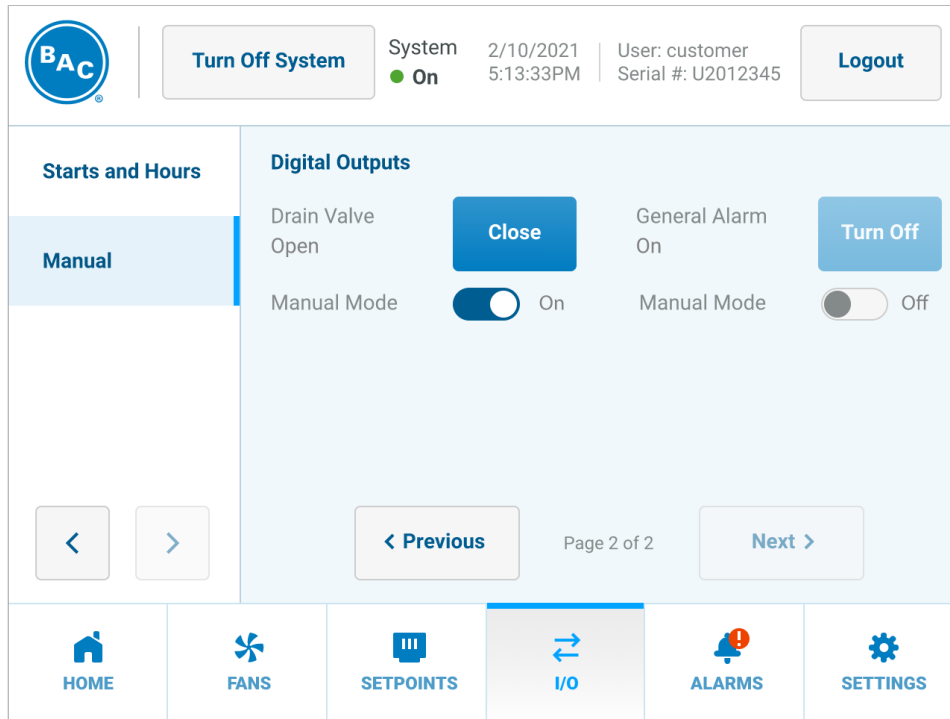

Figure 151. I/O Menu, Manual Page 2 of 2

Parameter	Description
Makeup Valve X	Force either make-up valve on or off.
Pump X Contact	Force either pump on or off.
Drain Valve	Force the drain valve open or closed.
General Alarm	Force the general alarm contact on or off.

Table 101. I/O Menu, Manual Parameters

Alarms

This menu allows a user to read and clear alarms. The alarm menu is shown in **Figure 152** with parameters listed in **Table 102**. All active alarms are displayed with a red font; inactive alarms are displayed in a black font. For a detailed overview of the different alarms, see **Appendix C – Alarms** on **Page 207**

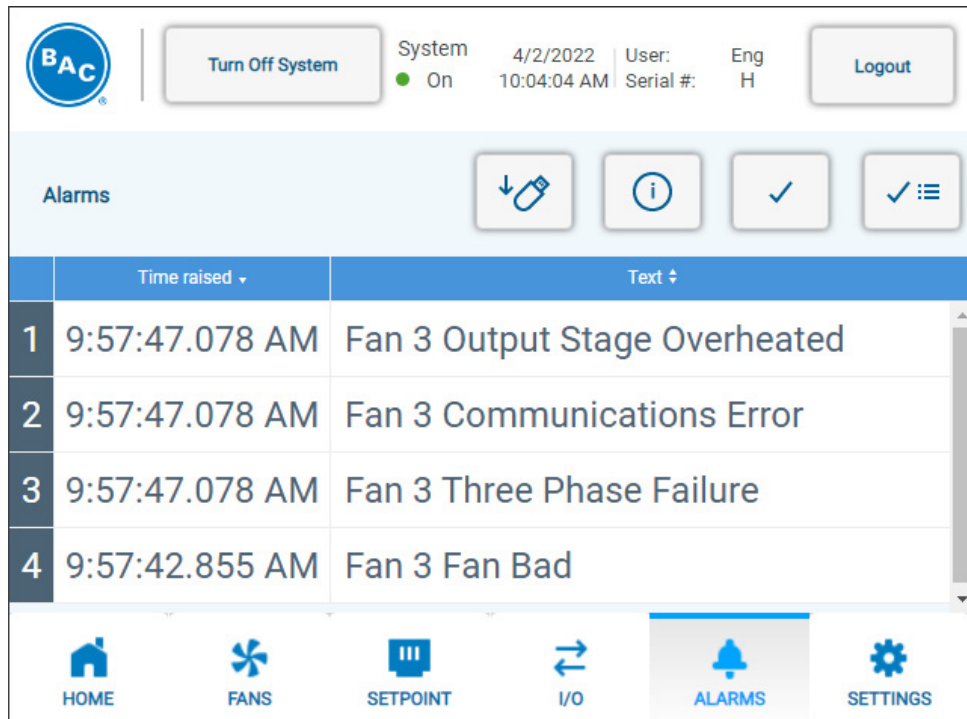

Figure 152. Alarms Menu





Parameter	Description
Download to USB 	Pressing the Download button will verify if a portable USB storage device is present in the USB bulkhead located inside the HMI enclosure and download the alarm log (a progress bar will indicate the status of the process).
Information 	Pressing the Information button will display the alarm detail page of the selected alarm as shown in Figure 153 .
Acknowledge Current 	Pressing the 'single checkmark' will clear the selected alarm.
Acknowledge All 	Pressing the 'multi-checkmark' will clear all active alarms and change the text from a red to a black font. A pop-up window will ask for a confirmation first.

Table 102. Alarm Menu Parameters

Alarm Details Page

Figure 153 is an example of the Alarm Details page. All possible alarms are listed in Table 111 through Table 148. There are 3 buttons on the left-hand side labeled Trigger Criteria, Release Criteria, and Troubleshooting. Pressing any of these buttons displays the respective information in the table for each alarm. Pressing the “Back” button returns the user to the Alarms menu.

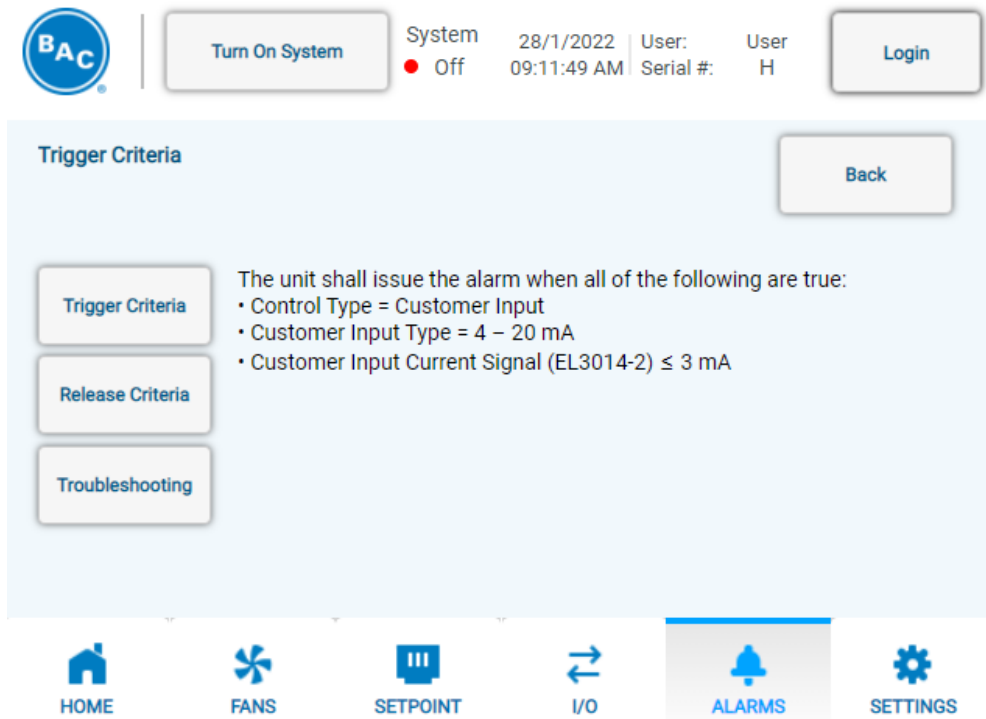

Figure 153. Alarms Menu, Alarm Details Page

Settings

With the parameters that can be set in this menu, the user can configure the behavior of the unit.

Setup Menu

The Setup menu is shown in **Figure 154** through **Figure 155** with parameters listed in **Table 103**.

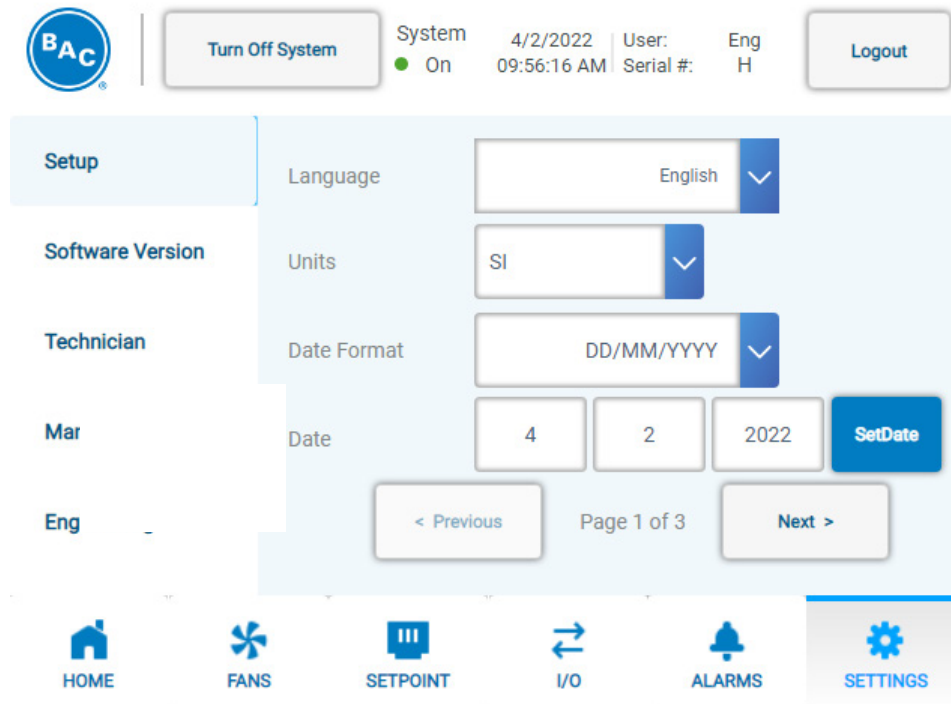

Figure 154. Settings Menu, Setup Page 1 of 3

Figure 155. Settings Menu, Setup Page 2 of 3

Figure 156. Settings Menu, Setup Page 3 of 3

Parameter	Description
Language	Determines the interface language.
Units	Determines the units of measurements for the different variables. This can be set to either SI or imperial.
Date Format	Determines in what order the day, month and year are shown. This can be set at MM/DD/YYYY, DD/MM/YYYY or YYYY/MM/DD.
Date	Allows user to change the current date (in the format chosen above).
24 Hour Time	Allows user to change the current time.
Daylight Savings	Enable or disable daylight savings time.
BMS Protocol	Select and configure the BMS bus system. Options are Modbus RTU, BACnet MSTP, BACnet IP & Modbus TCP. Pressing the “Configure” button displays the corresponding BMS Protocol Settings menu as shown in Figure 94 through Figure 101
Touchscreen	Pressing the “Calibrate” button above displays the touchscreen calibration screen and allow the user to calibrate the resistive touchscreen.
IP Address	Sets the correct value (in IPv4 format).
Subnet Mask	Sets the correct value (in IPv4 format).
Default Gateway	Sets the correct value (in IPv4 format).

Table 103. Settings Menu, Setup Parameters

Modbus RTU Setup

Selecting BMS Protocol Modbus RTU from the Setup menu shown in **Figure 155** and pressing the “Configure” button displays the Modbus RTU setup menu shown in **Figure 157** and **Figure 158** with parameters listed in **Table 104**.

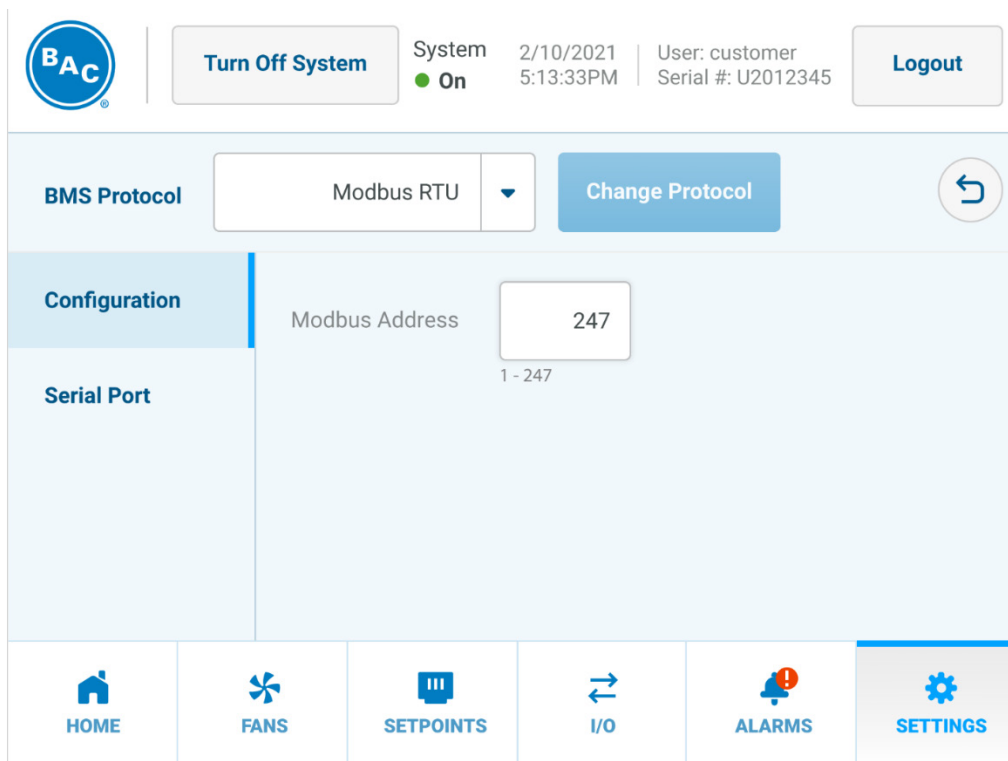

Figure 157. Settings Menu, Modbus RTU Configuration

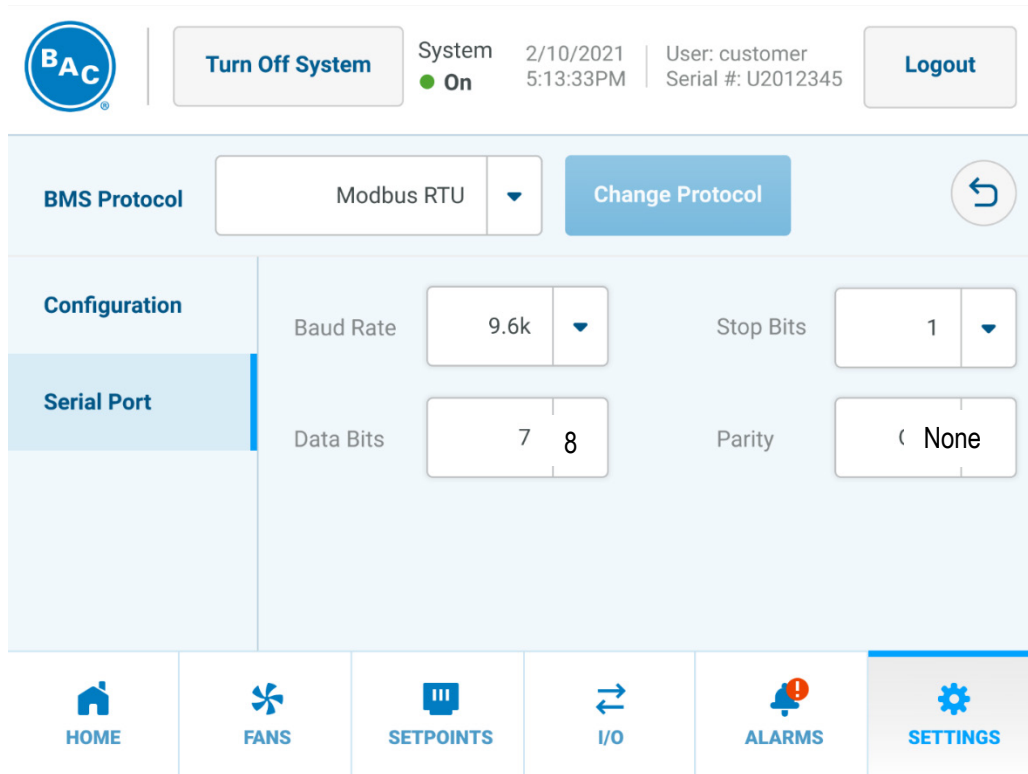

Figure 158. Settings Menu, Modbus RTU Serial Port

Parameter	Description
Modbus Address	Sets the units' network address
Baud Rate	Set the appropriate baud rate. Possible values (in kbps) are 9.6, 19.2, 38.4, 57.6 or 115.2
Data Bits	The number of data bits is always 8
Stop Bits	The number of stop bits always 1
Parity	The parity is always none

Table 104. Settings Menu, Modbus RTU Parameters

BACnet MSTP Setup

Selecting BMS Protocol BACnet MSTP from the setup menu shown in **Figure 155** and pressing the “Configure” button displays the BACnet MSTP setup menu shown in **Figure 159** and **Figure 160** with parameters listed in **Table 105**.

BAC | Turn Off System | System **On** | 2/10/2021 5:13:33PM | User: customer | Serial #: U2012345 | Logout

BMS Protocol: BACnet MSTP | Change Protocol

Configuration

Device Instance Number: 1 | Max Info Frames: 2 (0 - 255)

MAC Address: 127 (1 - 127) | Timeout: 500 ms (1 - 9999)

Max Master: 7 (0 - 127)

HOME | FANS | SETPOINTS | I/O | ALARMS | **SETTINGS**

Figure 159. Settings Menu, BACnet MSTP Configuration

BAC | Turn Off System | System **On** | 2/10/2021 5:13:33PM | User: customer | Serial #: U2012345 | Logout

BMS Protocol: BACnet MSTP | Change Protocol

Configuration

Baud Rate: 9.6k | Stop Bits: 1

Data Bits: 7 | Parity: Odd

HOME | FANS | SETPOINTS | I/O | ALARMS | **SETTINGS**

Figure 160. Settings Menu, BACnet MSTP Serial Port

Parameter	Description
Device Instance Number	Sets the correct value.
MAC Address	Sets the correct value.
Max Master	Sets the correct value.
Max Info Frames	Sets the correct value.
Timeout	Sets the correct value.
Baud Rate	Set the appropriate baud rate. Possible values (in kbps) are 9.6, 19.2, 38.4, 57.6 or 115.2.
Data Bits	The number of data bits is always 8.
Stop Bits	The number of stop bits always 1.
Parity	The parity is always odd.

Table 105. Settings Menu, BACnet MSTP Parameters

Modbus TCP Setup

Selecting BMS Protocol Modbus TCP from the setup menu shown in **Figure 155** and pressing the “Configure” button displays the Modbus TCP setup menu shown in **Figure 161** and **Figure 162** with parameters listed in **Table 106**.

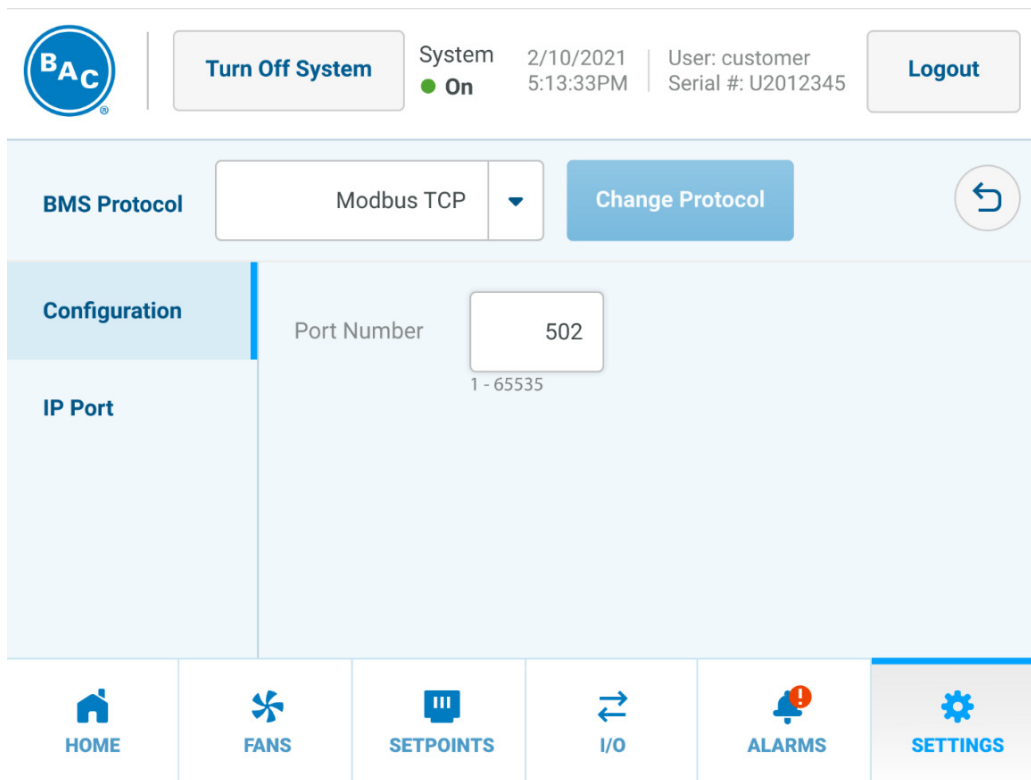

Figure 161. Settings Menu Modbus TCP Configuration

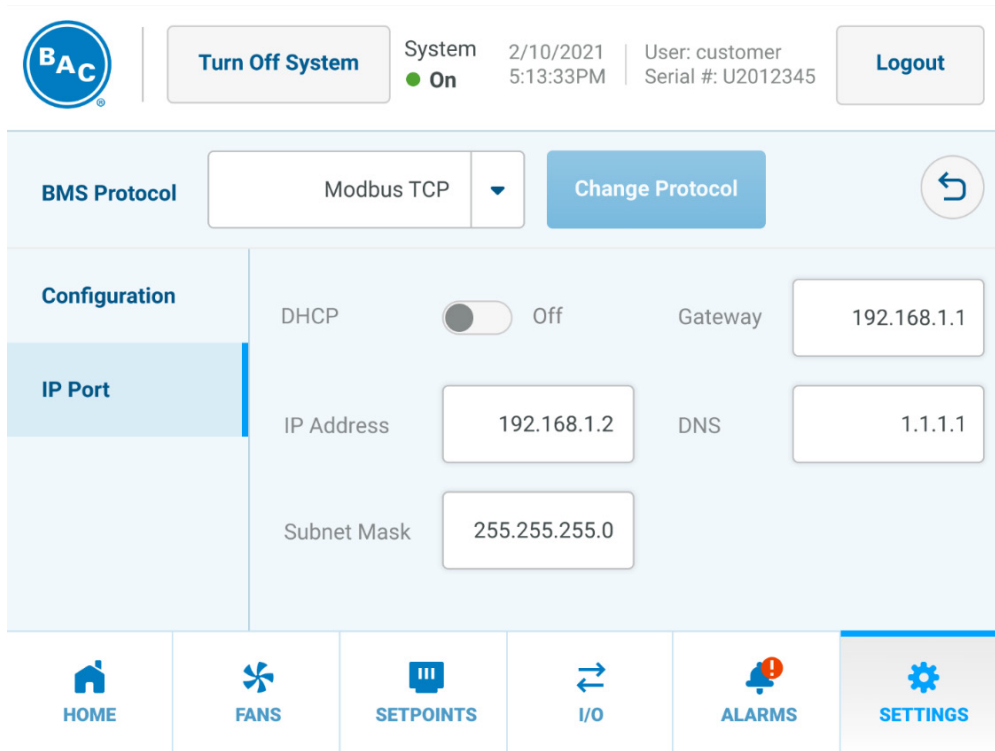

Figure 162. Settings Menu, Modbus TCP IP Port

Parameter	Description
Port Number	Sets the correct value.
DHCP	Enable to get address assigned automatically.
IP Address	Sets the correct value (in IPv4 format).
Subnet Mask	Sets the correct value (in IPv4 format).
Gateway	Sets the correct value (in IPv4 format).
DNS	Sets the correct value (in IPv4 format).

Table 106. Settings Menu, Modbus TCP Parameters

BACnet IP Setup

Selecting BMS Protocol BACnet IP from the setup menu shown in **Figure 155** and pressing the “Configure” button displays the BACnet IP setup menu shown in **Figure 163** and **Figure 164** with parameters listed in **Table 107**.

The screenshot displays the BACnet IP Configuration settings menu. At the top left is the BAC logo. To its right is a 'Turn Off System' button. Further right, system status is shown as 'System On' with a green dot, along with the date and time '2/10/2021 5:13:33PM'. User information 'User: customer' and 'Serial #: U2012345' is also present, followed by a 'Logout' button.

The main configuration area is divided into two sections: 'BMS Protocol' and 'Configuration'. The 'BMS Protocol' section shows 'BACnet IP' selected in a dropdown menu, with a 'Change Protocol' button and a refresh icon. The 'Configuration' section is further divided into 'IP Port' and 'Device Instance Number'. The 'Device Instance Number' is set to '1'. The 'IP Port' section includes 'Network Number' (1) and 'Port Number' (47808). The 'Timeout' is set to '500 ms'. Range indicators are shown below the port number (1 - 65535) and timeout (1-9999) fields.

At the bottom, a navigation bar contains icons and labels for 'HOME', 'FANS', 'SETPOINTS', 'I/O', 'ALARMS', and 'SETTINGS'. The 'SETTINGS' icon is highlighted with a blue bar.

Figure 163. Settings Menu, BACnet IP Configuration

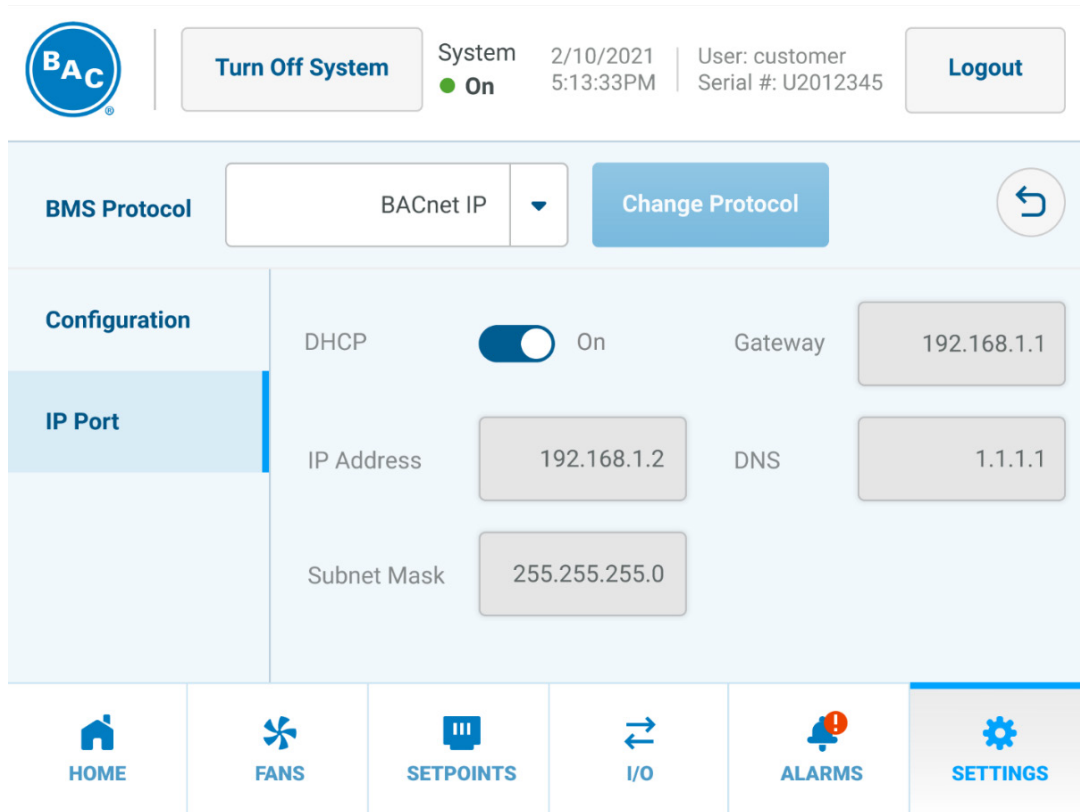

Figure 164. Settings Menu, BACnet IP IP Port

Parameter	Description
Device Instance Number	Sets the correct value.
Network Number	Sets the correct value.
Port Number	Sets the correct value.
DHCP	Enable to get address assigned automatically.
IP Address	Sets the correct value (in IPv4 format).
Subnet Mask	Sets the correct value (in IPv4 format).
Gateway	Sets the correct value (in IPv4 format).
DNS	Sets the correct value (in IPv4 format).

Table 107. Settings Menu, BACnet IP Parameters

Software Version Menu

The Software Version menu is shown in **Figure 165** through **Figure 167** with parameters listed in **Table 108**.

BAC | [Turn Off System](#) | System ● On | 2/10/2021 5:13:33PM | User: customer Serial #: U2012345 | [Logout](#)

Setup	Software Version T3.X.Y.BBB	OS Version Windows 10 Enterprise LTSC Build 1809
Software Version	Control Version X.Y	
Technician	TwinCAT Version V3.1.4024.12	TwinCAT HMI Server Version 1.12.742.5

[< Previous](#) | Page 1 of 3 | [Next >](#)

[HOME](#) | [FANS](#) | [SETPOINTS](#) | [I/O](#) | [ALARMS](#) | [SETTINGS](#)

Figure 165. Settings Menu, Software Version Page 1 of 3

BAC | [Turn Off System](#) | System ● On | 2/10/2021 5:13:33PM | User: customer Serial #: U2012345 | [Logout](#)

Setup	Config File	<input type="text" value="Config_0.txt"/>	Load
Software Version	Export Config	Export	
Technician			

[< Previous](#) | Page 2 of 3 | [Next >](#)

[HOME](#) | [FANS](#) | [SETPOINTS](#) | [I/O](#) | [ALARMS](#) | [SETTINGS](#)

Figure 166. Settings Menu, Software Version Page 2 of 3

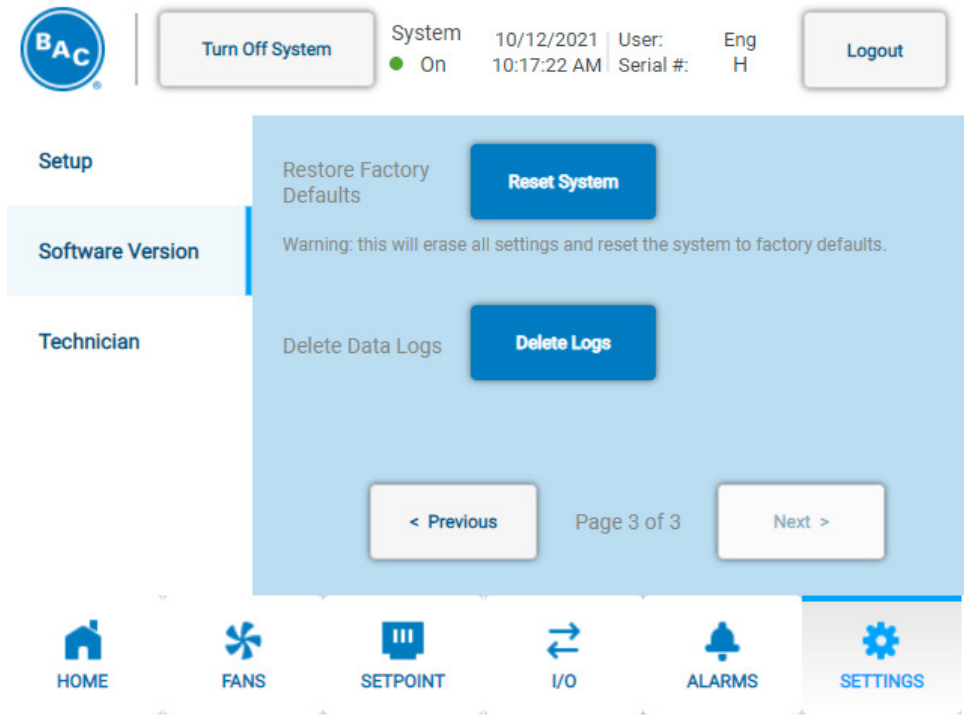

Figure 167. Settings Menu, Software Version Page 3 of 3

Parameter	Description
Software Version	Indicates the current version.
Control Version	Indicates the current version.
TwinCAT Version	Indicates the current version.
TwinCAT HMI Server Version	Indicates the current version.
OS Version	Indicates the current version.
Config File	Load a config file from a USB storage device. The file needs to be a text file stored as "E:\BAC\Config\..."
Export Config	Export the current settings.
Restore Factory Defaults	Reset all settings to the factory defaults. All custom settings will be removed. A Manufacturing password is required for this action. Contact your local BAC Representative for assistance.
Delete Data Logs	Pressing the "Delete Logs" button erases all data logging files. The Technician password is required. Refer to Table 83. Access Levels and Passwords on Page 154 .

Table 108. Settings Menu, Software Version Parameters

Technician Menu

The Technician menu is only displayed and accessible with Technician access level. Refer to **Table 83. Access Levels and Passwords** on **Page 154**. The Technician menu is shown in **Figure 168** and **Figure 169** with parameters listed in **Table 109**.

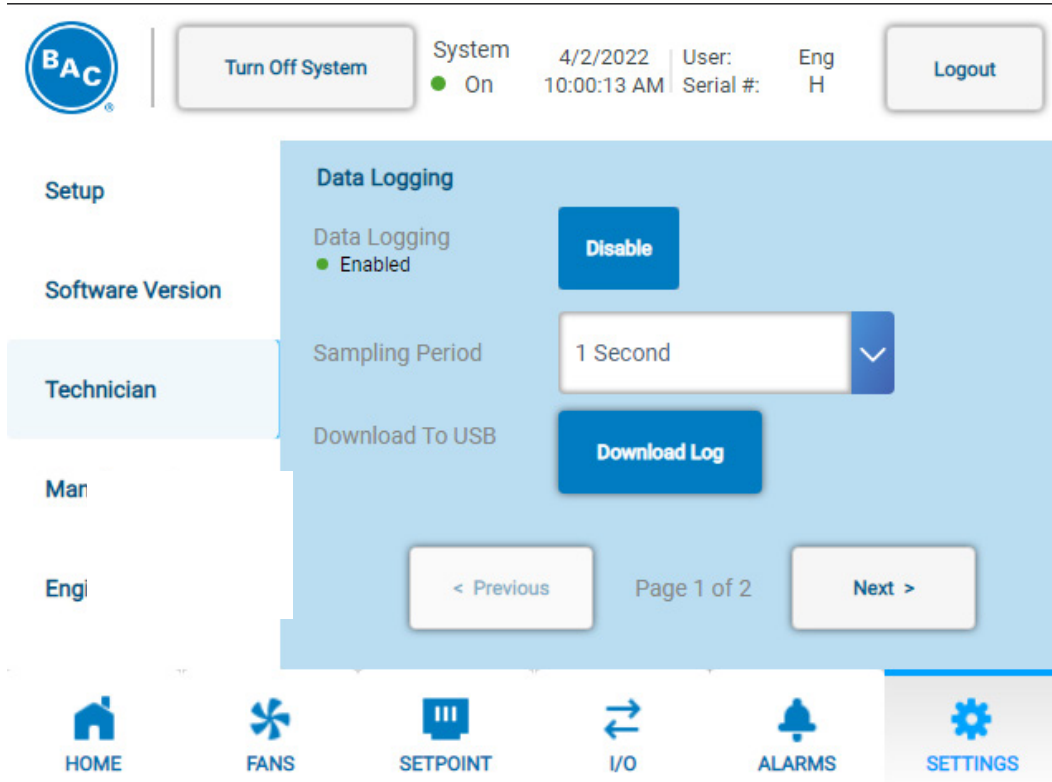

Figure 168. Settings Menu, Technician Page 1 of 2

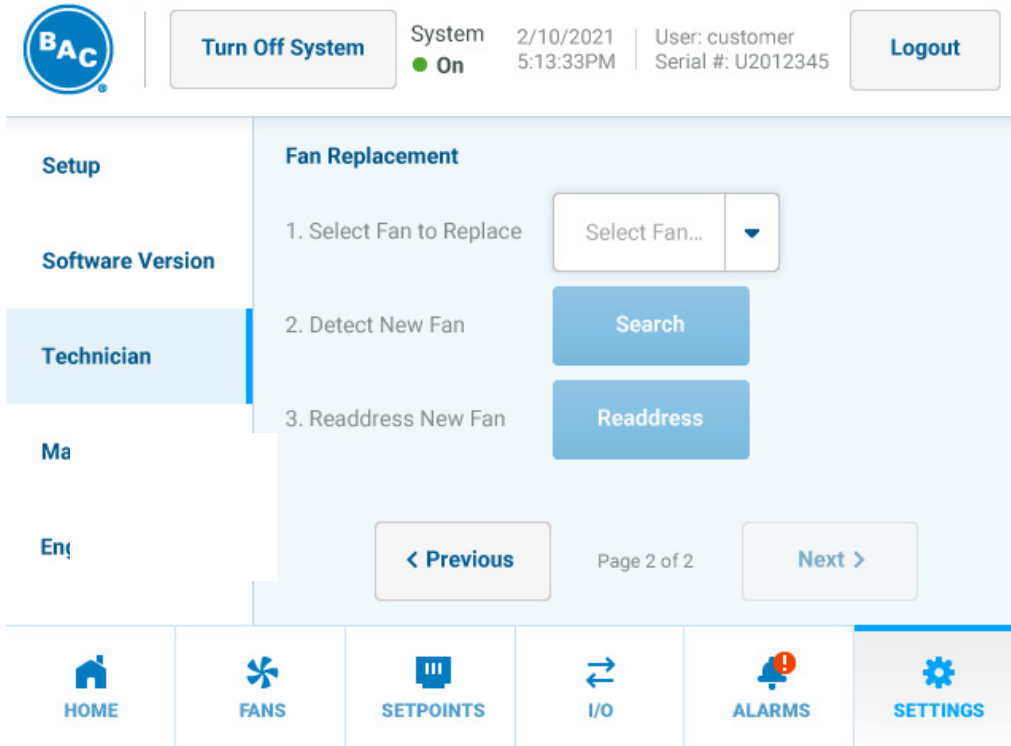

Figure 169. Settings Menu, Technician Page 2 of 2

Parameter	Description
Data Logging	Allows user to enable or disable the feature. If enabled, all statuses will be logged at regular intervals (see sampling period).
Sampling Period	Interval at which all statuses are stored to the log (if enabled).
Download to USB	Export to log file to a USB storage device.
Select Fan to Replace	Choose the address that needs to be programmed into the new fan.
Detect New Fan	Search for the address of the new fan.
Readdress New Fan	Set the correct address in the new fan.

Table 109. Settings Menu, Technician Parameters

Data Logging Retrieval

Onboard data-logging records and stores the data listed in **Table 110**, which can be loaded onto a portable USB storage device in a comma separated value (CSV) file. The sampling period is determined by the Sampling Period shown in **Figure 169** and listed in **Table 109**. This information can be used for troubleshooting or energy modeling purposes. Data logging can be enabled/disabled via the Technician menu shown in **Figure 169**. To retrieve data-logging information:

1. Insert a portable USB storage device into the USB bulkhead located inside the HMI enclosure.
2. Navigate to Settings menu, Technician Page 1 of 2 shown in **Figure 169**. Press “Download Log”. A loading bar will appear and display the current progress of the file downloads until complete.

Table 110. Data Logging Parameters

Variable Name	Description
TimeStamp	Time Stamp in HHMMSS format
LFT	Leaving Fluid Temperature [°C] in tenths precision
LFTsetp	Leaving Fluid Temperature Setpoint [°C] in tenths precision
CtrlRange	Control Range [°C] in tenths precision
OAT	Outside Air Temperature [°C] in tenths precision
AdiabaticSP	Adiabatic Swithpoint [°C] in tenths precision
LLF	Low Level Float Status 0 = Water Level below Float 1 = Water Level above Float
MLF	Mid Level Float Status 0 = Water Level below Float 1 = Water Level above Float
HLF	High Level Float Status 0 = Water Level below Float 1 = Water Level above Float
PumpXCS	Pump X Current Switch 0 = No Current Detected 1 = Current Detected
FanSpdCmd	Fan Speed Command [% max fan speed] in tenths precision
FanSpdCmdRPM	Fan Speed Command [RPM] in x1 format
ActlFanSpdRPM	Average Actual Fan Speed Feedback [RPM] in tenths precision
FanDirection	Fan Direction 0 = Forward 1 = Reverse
MUPX	Make Up Valve X Command 0 = Closed 1 = Open

Table 110. Data Logging Parameters	
Variable Name	Description
DrainVlv	Drain Valve Command 0 = Open 1 = Closed
CoCdrainActive	Cycles of Concentration Drain Active 0 = CoC Drain is inactive 1 = CoC Drain is active
NumCoCs	Number of Cycles of Concentration till Basin drain
CoCcount	Cycles of Concentration Count Number of Cycles of concentration that have occurred since the last drain
BasinRetentionTime	Basin Retention Time [hours] The amount of time in Dry mode that the unit will hold the basin water before dumping.
PumpXCmd	Pump X Command 0 = Off 1 = On
PumpXARTactive	Pump X Anti-Recycle Timer Active 0 = Pump 1 AR timer is inactive 1 = Pump 1 AR timer is active
RunAuthType	Run Authorization Type 0 = Undefined 1 = HMI 2 = DI 3 = BMS
HMIRunAuth	HMI Run Authorization Status 0 = Off 1 = On
DIrunAuth	Digital Input Run Authorization Status (MATLAB RemoteRunEn) 0 = Off 1 = On
BMSrunAuth	BMS Run Authorization Status 0 = Off 1 = On
DisableWater	Disable Water Usage via HMI or BMS (NO) 0 = Water Usage Allowed 1 = Water Usage Not Allowed
DisableWaterDI	Disable Water Usage DI (NO) 0 = Water Usage Allowed 1 = Water Usage Not Allowed
NightDryEn	Night Dry Enable 0 = Night Dry is not active 1 = Night Dry is active via BMS, HMI, or Schedule
ScheduleDryEn	Schedule Dry Enable 0 = Schedule Dry is not active 1 = Schedule Dry is active via BMS, HMI, or Schedule

Table 110. Data Logging Parameters	
Variable Name	Description
NightQuietEn	Night Quiet Active 0 = Inactive 1 = Active
NightQuietLim	Night Quiet Limit [% max fan speed]
NightQuietAdiaSP	Night Quiet Adiabatic Switchpoint [°C]
UnitMode	Control State (from State Machine)
PrecoolerXStatus	Precooler X status 0 = Lead 1 = Lag
UnitAlarmCode	Unit Alarm Code (see Table 149)
FanAlarmCode	Fan Alarm Code (see Table 150)
GeneralAlarmDO	General Alarm DO 0 = No Alarm Active 1 = Alarm Active
AvgFanActISpd	Average Fan Speed Feedback [RPM] in tenths precision
AvgFanPwr	Average Fan Power [kW] in tenths precision
AvgFanCurr	Average Fan Current [A] in tenths precision
PrecoolerXStarts	Precooler X number of starts
PrecoolerXHrs	Precooler X run hours
PumpXStarts	Pump X number of starts
PumpXHrs	Pump X run hours [hours]
MUPXstarts	Make Up Valve X starts
MUPXhrs	Make Up Valve X run hours [hours]
DrainVlvStarts	Drain Valve starts
DrainVlvHrs	Drain Valve run hours [hours]
FanHours[X]	Fan X run hours [hours]

Table 110. Data Logging Parameters

Readdress New Fan

Replacement fans must be readdressed prior to unit operation. Refer to section **BAC Part Number 251299, Fan and Motor Removal & Installation on Page 35** or **BAC Part Number 251317 EC Fan and Motor Assembly Removal & Installation on Page 41** for instructions on removing and installing fans. Each fan needs to be assigned a unique address, starting with “1,2,3,...”. Replacement fans are pre-programmed with a default Modbus address of 247. Only one new fan can be readdressed at a time. If replacing multiple fans at a time, start with the fan closest to the control panel on the right side, Fan 2 in **Figure 170**. To address a newly installed fan:

6. Log in as Technician. Refer to **Table 83. Access Levels and Passwords on Page 154**.
7. Navigate to Settings menu, Technician Page 2 of 2 as shown in **Figure 169**.
8. Use the dropdown menu titled “Select Fan to Replace” to select the correct fan number. Refer to **Figure 170** to identify the correct fan number.
9. After selecting the fan that has been replaced, press the “Search” button. “Searching for Fans...” will be displayed to the left of the Search button.
10. When the new fan has been detected, a green checkmark icon will appear as shown in **Figure 171**. Press the “Readdress” button. Next press the “Readdress Fan” button to confirm readdress. The selected fan will be readdressed.

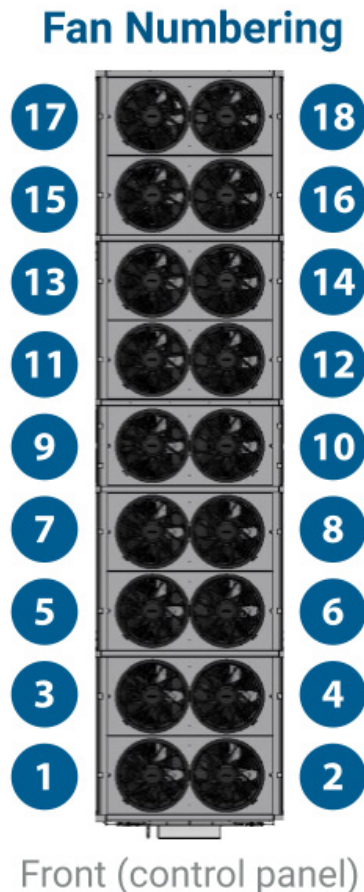

Figure 170. Fan Numbering Plan View

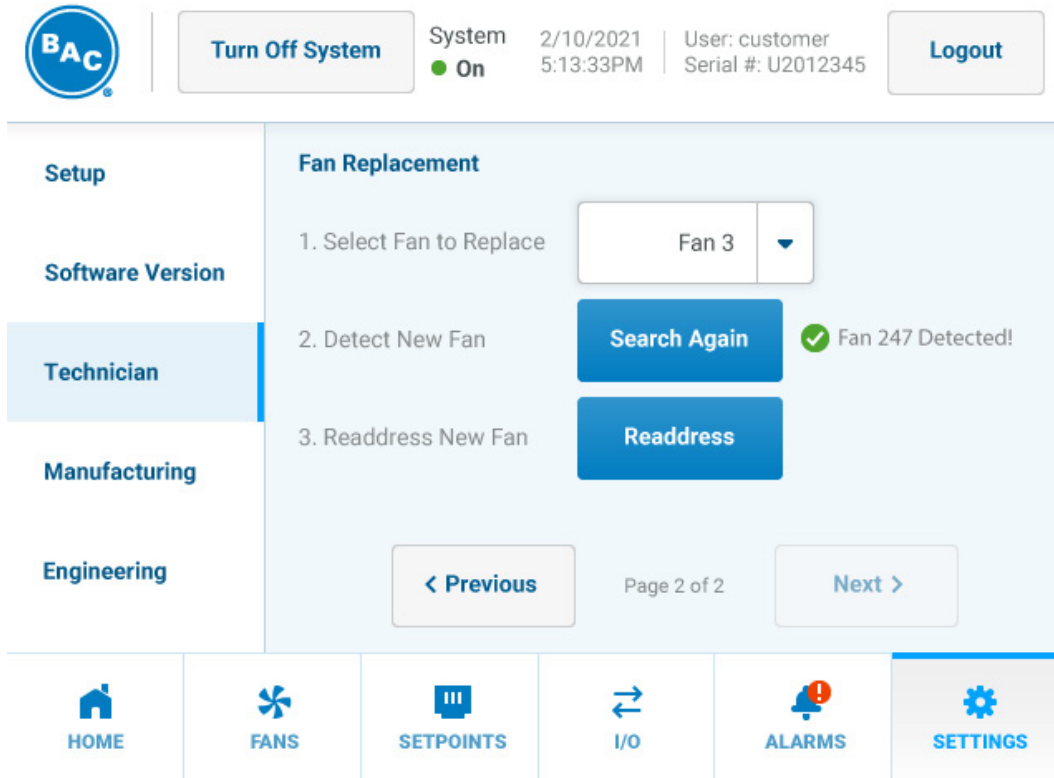

Figure 171. Settings Menu, Technician Page 2 of 2 Fan Detect

Headless HMI

The control panel is equipped with a headless HMI feature allowing a user to view the HMI on an external device. Follow the below instructions to utilize the headless HMI feature.

1. Navigate to Settings menu, Setup Page 3 of 3 as shown in **Figure 156**.
 - a. Note the IP Address shown on the screen.
2. Connect a RJ45 cable from an external device to the control panel via the bulkhead at the bottom on the control panel.
3. On the external device open a web browser and enter the IP Address followed by “:1011”.
4. Allow TwinCAT HMI to load and go to the Home Screen.

Appendix C – Alarms Part #313976

Unit Alarms & Troubleshooting

Unit alarms and troubleshooting recommendations are listed in **Table 111** through **Table 125**. Unit alarm codes are listed in **Table 149**.

Parameter	Condition
Trigger Criteria	The unit will issue the alarm when all the following are true: <ul style="list-style-type: none"> • Pump X Contact is On for 10 consecutive seconds • Pump X Current Switch is False for 3 consecutive seconds
Release Criteria	The unit will release the alarm when any of the following are true: <ul style="list-style-type: none"> • Pump X Contact is Off • Pump X Contact is On AND Pump X Current Switch is True
Troubleshooting	<ul style="list-style-type: none"> • Check Pump X and wiring • Check Pump X Current Switch and wiring
General Alarm DO	True
Effect	If this alarm occurs 3 times, Pump X will be locked out and the alarm must be cleared via the HMI.

Table 111. Pump X No Current Alarm

Parameter	Condition
Trigger Criteria	The unit will issue the alarm when the following is true: <ul style="list-style-type: none"> • 3 Pump X No Current Alarms have occurred
Release Criteria	The unit will release the alarm when the following is true: <ul style="list-style-type: none"> • Pump X Lockout is cleared
Troubleshooting	<ul style="list-style-type: none"> • Check Pump X and wiring • Check Pump X Current Switch and wiring
General Alarm DO	True
Effect	Pump X will be locked out from starting.

Table 112. Pump X Lock Out Alarm

Parameter	Condition
Trigger Criteria	The unit will issue the alarm when any of the following are true: <ul style="list-style-type: none"> • Control Type = LFT Ctrl AND Fluid Type = Water AND Leaving Fluid Temperature ≤ 10 °C for 3 consecutive seconds • Control Type = LFT Ctrl AND Fluid Type = Glycol AND Leaving Fluid Temperature ≤ 7.2 °C for 3 consecutive seconds
Release Criteria	The unit will release the alarm when any of the following are true: <ul style="list-style-type: none"> • Control Type = LFT Ctrl AND Fluid Type = Water AND Leaving Fluid Temperature > 13 °C for 3 consecutive seconds • Control Type = LFT Ctrl AND Fluid Type = Glycol AND Leaving Fluid Temperature > 10.2 °C for 3 consecutive seconds • Control Type ≈ LFT Ctrl
Troubleshooting	<ul style="list-style-type: none"> • Check Leaving Fluid Temperature sensor installation • Check Leaving Fluid Temperature sensor and wiring
General Alarm DO	True
Effect	Emergency Flag = True

Table 113. Low Leaving Fluid Temperature Alarm

Parameter	Condition
Trigger Criteria	The unit will issue the alarm when all the following are true: <ul style="list-style-type: none"> • Low Level Float = False for 5 consecutive minutes • Drain Valve = Closed
Release Criteria	The unit will release the alarm when the following is true: <ul style="list-style-type: none"> • Low Level Float = True for 3 consecutive seconds
Troubleshooting	<ul style="list-style-type: none"> • Check Low Level Float and wiring • Check Drain Valve and wiring
General Alarm DO	True
Effect	N/A

Table 114. Low Water Basin Alarm

Parameter	Condition
Trigger Criteria	The unit will issue the alarm when following is true: <ul style="list-style-type: none"> • High Level Float = True for 5 consecutive minutes
Release Criteria	The unit will release the alarm when following is true: <ul style="list-style-type: none"> • High Level Float = False for 3 consecutive seconds
Troubleshooting	<ul style="list-style-type: none"> • Check High Level Float • Check High Level Float wiring • Check Make Up Valve 1 and wiring • Check Make Up Valve 2 and wiring • Check Drain Valve and wiring • Check Drain Valve Piping
General Alarm DO	True
Effect	N/A

Table 115. High Basin Water Alarm

Parameter	Condition
Trigger Criteria	The unit will issue the alarm when all the following are true: <ul style="list-style-type: none"> • Drain Valve = Open • Low Level Float = True for 45 consecutive minutes
Release Criteria	The unit will release the alarm when the following is true: <ul style="list-style-type: none"> • Low Level Float = False for 3 consecutive seconds
Troubleshooting	<ul style="list-style-type: none"> • Check Low Level Float and wiring • Check Drain Valve and wiring
General Alarm DO	True
Effect	N/A

Table 116. Drain Valve Alarm

Parameter	Condition
Trigger Criteria	The unit will issue the alarm when all the following are true: <ul style="list-style-type: none"> • Make Up Valve X = Open • Drain Valve = Closed • Low Level Float = False for 6 minutes
Release Criteria	The unit will release the alarm when the following is true: <ul style="list-style-type: none"> • Low Level Float = True for 3 consecutive seconds
Troubleshooting	<ul style="list-style-type: none"> • Check Make Up Valve X • Check Low Level Float and wiring • Check Drain Valve and wiring
General Alarm DO	True
Effect	N/A

Table 117. Make Up X Alarm

Parameter	Condition
Trigger Criteria	The unit will issue the alarm when all the following are true: <ul style="list-style-type: none"> • Make Up 1 Alarm is Active • Make Up 2 Alarm is Active
Release Criteria	The unit will release the alarm when any of the following are true: <ul style="list-style-type: none"> • Low Level Float = True for 3 consecutive seconds • Drain Valve = Open
Troubleshooting	<ul style="list-style-type: none"> • Check Make Up Valve 1 • Check Low Level Float and wiring • Check Drain Valve and wiring • Check Make Up Valve 2 • Check Low Level Float and wiring • Check Drain Valve and wiring
General Alarm DO	True
Effect	N/A

Table 118. Water Supply Alarm

Parameter	Condition
Trigger Criteria	The unit will issue the alarm when all the following are true: <ul style="list-style-type: none"> • Control Type = LFT Ctrl • Leaving Fluid Temperature > 90 °C OR • Leaving Fluid Temperature < -50 °C OR • EL3208-0010 Channel 1 cable break detected
Release Criteria	The unit will release the alarm when any of the following are true: <ul style="list-style-type: none"> • Control Type != LFT Ctrl • Leaving Fluid Temperature ≤ 87 °C • Leaving Fluid Temperature ≥ -47 °C • EL3208-0010 Channel 1 cable break undetected
Troubleshooting	<ul style="list-style-type: none"> • Check Leaving Fluid Temperature sensor installation • Check Leaving Fluid Temperature sensor and wiring
General Alarm DO	True
Effect	Emergency Flag = True

Table 119. Leaving Fluid Temperature Sensor Alarm

Parameter	Condition
Trigger Criteria	The unit will issue the alarm when any of the following are true: <ul style="list-style-type: none"> • Outside Air Temperature < -30 °C for 3 consecutive seconds • Outside Air Temperature > 60 °C for 3 consecutive seconds • EL3208-0010 Channel 2 cable break detected
Release Criteria	The unit will release the alarm when any of the following are true: <ul style="list-style-type: none"> • Outside Air Temperature ≥ -27 °C for 3 consecutive seconds AND Outside Air Temperature ≤ 57 °C for 3 consecutive seconds • EL3208-0010 Channel 2 cable break is not detected
Troubleshooting	<ul style="list-style-type: none"> • Check Outside Air Temperature sensor installation • Check Outside Air Temperature sensor and wiring
General Alarm DO	True
Effect	Disable Water = True

Table 120. Outside Air Temperature Sensor Alarm

Parameter	Condition
Trigger Criteria	The unit will issue the alarm when the following is true: <ul style="list-style-type: none"> • All fans time out Modbus communications
Release Criteria	The unit will release the alarm when the following is true: <ul style="list-style-type: none"> • Any fan regains Modbus communications
Troubleshooting	<ul style="list-style-type: none"> • Check E-Stop button • Check Fan Modbus wiring between control panel and fan 1
General Alarm DO	True
Effect	Disable Water = True

Table 121. All Fans Offline/E-Stop Alarm

Parameter	Condition
Trigger Criteria	The unit will issue the alarm when any of the following are true: <ul style="list-style-type: none"> • Low Level Float = False for 60 consecutive seconds • Mid Level Float = True • High Level Float = True
Release Criteria	The unit will release the alarm the following is true: <ul style="list-style-type: none"> • Low Level Float = True for 3 consecutive seconds
Troubleshooting	<ul style="list-style-type: none"> • Check Low Level Float Switch • Check Low Level Float Switch wiring
General Alarm DO	True
Effect	N/A

Table 122. Low Level Float Alarm

Parameter	Condition
Trigger Criteria	The unit will issue the alarm when any of the following are true: <ul style="list-style-type: none"> • Low Level Float = True • Mid Level Float = False for 60 consecutive seconds • High Level Float = True
Release Criteria	The unit will release the alarm when the following is true: <ul style="list-style-type: none"> • Mid Level Float = True for 3 consecutive seconds
Troubleshooting	<ul style="list-style-type: none"> • Check Mid Level Float Switch • Check Mid Level Float Switch wiring
General Alarm DO	True
Effect	N/A

Table 123. Mid Level Float Alarm

Parameter	Condition
Trigger Criteria	The unit will issue the alarm when all the following are true: <ul style="list-style-type: none"> • Control Type == Customer Input • Customer Input Type = 4 – 20 mA • Customer Input Current Signal (EL3014-2) \leq 3 mA
Release Criteria	The unit will release the alarm when any of the following are true: <ul style="list-style-type: none"> • Control Type != Customer Input AND Customer Input Type = 4 – 20 mA AND Customer Input Current Signal (EL3014-2) $>$ 3 mA • Control Type ~= Customer Input • Customer Input Type ~= 4 – 20 mA
Troubleshooting	<ul style="list-style-type: none"> • Check Customer Input wiring • Verify proper software set up
General Alarm DO	True
Effect	Emergency Mode = Active

Table 124. Low Customer Input Current Alarm

Parameter	Condition
Trigger Criteria	The unit will issue the alarm when all the following are true: <ul style="list-style-type: none"> • Control Type == LFT Control • LFT > 85.0 °C
Release Criteria	The unit will release the alarm when any of the following are true: <ul style="list-style-type: none"> • Control Type != LFT Control AND LFT <= 82 °C • Control Type != LFT Control
Troubleshooting	<ul style="list-style-type: none"> • Check fluid temperatures elsewhere in the loop • Check leaving fluid temperature sensor
General Alarm DO	True
Effect	N/A

Table 125. High Leaving Fluid Temperature Alarm

Fan Alarms & Troubleshooting, BAC Part Number 251299

Fan alarms and troubleshooting recommendations for BAC fan part number 251299 are listed in **Table 126** through **Table 136**. Fan alarm codes are listed in **Table 150**. Refer to section **Fan Types** on **Page 33** for more information on how to identify fan type and part number.

Parameter	Condition
Trigger Criteria	The unit will issue the alarm when all the following are true: <ul style="list-style-type: none"> • Number of Fans ≥ Fan X • Fan X times out Modbus communications
Release Criteria	The unit will release the alarm when any of the following are true: <ul style="list-style-type: none"> • Number of Fans < Fan X • Fan X regains Modbus communications
Troubleshooting	Check Fan X's circuit breaker in control panel
General Alarm DO	True
Effect	N/A

Table 126. Fan X Offline Alarm

Parameter	Condition
Trigger Criteria	The unit will issue the alarm when all the following are true: <ul style="list-style-type: none"> • Number of Fans ≥ Fan X • Fan X Modbus Address D011 MSB bit 5 = 1
Release Criteria	The unit will release the alarm when any of the following are true: <ul style="list-style-type: none"> • Number of Fans < Fan X • Fan X Modbus Address D011 MSB bit 5 = 0
Troubleshooting	Check power supply to unit
General Alarm DO	True
Effect	N/A

Table 127. Fan X DC-link Undervoltage Alarm

Parameter	Condition
Trigger Criteria	The unit will issue the alarm when all the following are true: <ul style="list-style-type: none"> • Number of Fans \geq Fan X • Fan X Modbus Address D011 MSB bit 3 = 1
Release Criteria	The unit will release the alarm when any of the following are true: <ul style="list-style-type: none"> • Number of Fans $<$ Fan X • Fan X Modbus Address D011 MSB bit 3 = 0
Troubleshooting	Contact your BAC Representative for support
General Alarm DO	True
Effect	N/A

Table 128. Fan X Position Sensor Calibration Error Alarm

Parameter	Condition
Trigger Criteria	The unit will issue the alarm when all the following are true: <ul style="list-style-type: none"> • Number of Fans \geq Fan X • Fan X Modbus Address D011 MSB bit 1 = 1
Release Criteria	The unit will release the alarm when any of the following are true: <ul style="list-style-type: none"> • Number of Fans $<$ Fan X • Fan X Modbus Address D011 MSB bit 1 = 0
Troubleshooting	Contact your BAC Representative for support
General Alarm DO	True
Effect	N/A

Table 129. Fan X Speed Limit Exceeded Alarm

Parameter	Condition
Trigger Criteria	The unit will issue the alarm when all the following are true: <ul style="list-style-type: none"> • Number of Fans \geq Fan X • Fan X Modbus Address D011 LSB bit 8 = 1
Release Criteria	The unit will release the alarm when any of the following are true: <ul style="list-style-type: none"> • Number of Fans $<$ Fan X • Fan X Modbus Address D011 LSB bit 8 = 0
Troubleshooting	Inspect Fan X and ensure there are no obstructions
General Alarm DO	True
Effect	N/A

Table 130. Fan X Motor Blocked Alarm

Parameter	Condition
Trigger Criteria	The unit will issue the alarm when all the following are true: <ul style="list-style-type: none"> • Number of Fans \geq Fan X • Fan X Modbus Address D011 LSB bit 7 = 1
Release Criteria	The unit will release the alarm when any of the following are true: <ul style="list-style-type: none"> • Number of Fans $<$ Fan X • Fan X Modbus Address D011 LSB bit 7 = 0
Troubleshooting	Contact your BAC Representative for support
General Alarm DO	True
Effect	N/A

Table 131. Fan X Motor Hall Sensor Error Alarm

Parameter	Condition
Trigger Criteria	The unit will issue the alarm when all the following are true: <ul style="list-style-type: none"> • Number of Fans \geq Fan X • Fan X Modbus Address D011 LSB bit 6 = 1
Release Criteria	The unit will release the alarm when any of the following are true: <ul style="list-style-type: none"> • Number of Fans $<$ Fan X • Fan X Modbus Address D011 LSB bit 6 = 0
Troubleshooting	Contact your BAC Representative for support
General Alarm DO	True
Effect	N/A

Table 132. Fan X Motor Overheating Alarm

Parameter	Condition
Trigger Criteria	The unit will issue the alarm when all the following are true: <ul style="list-style-type: none"> • Number of Fans \geq Fan X • Fan X Modbus Address D011 LSB bit 5 = 1
Release Criteria	The unit will release the alarm when any of the following are true: <ul style="list-style-type: none"> • Number of Fans $<$ Fan X • Fan X Modbus Address D011 LSB bit 5 = 0
Troubleshooting	Contact your BAC Representative for support
General Alarm DO	True
Effect	N/A

Table 133. Fan X Fan Bad (General Error) Alarm

Parameter	Condition
Trigger Criteria	The unit will issue the alarm when all the following are true: <ul style="list-style-type: none"> • Number of Fans \geq Fan X • Fan X Modbus Address D011 LSB bit 4 = 1
Release Criteria	The unit will release the alarm when any of the following are true: <ul style="list-style-type: none"> • Number of Fans $<$ Fan X • Fan X Modbus Address D011 LSB bit 4 = 0
Troubleshooting	<ul style="list-style-type: none"> • Check Fan X communication wiring • Check Fan X communication shielding
General Alarm DO	True
Effect	N/A

Table 134. Fan X Communication Error Alarm

Parameter	Condition
Trigger Criteria	The unit will issue the alarm when all the following are true: <ul style="list-style-type: none"> • Number of Fans \geq Fan X • Fan X Modbus Address D011 LSB bit 3 = 1
Release Criteria	The unit will release the alarm when any of the following are true: <ul style="list-style-type: none"> • Number of Fans $<$ Fan X • Fan X Modbus Address D011 LSB bit 3 = 0
Troubleshooting	Contact your BAC Representative for support
General Alarm DO	True
Effect	N/A

Table 135. Fan X Output Stage Overheating Alarm

Parameter	Condition
Trigger Criteria	The unit will issue the alarm when all the following are true: <ul style="list-style-type: none"> • Number of Fans \geq Fan X • Fan X Modbus Address D011 LSB bit 1 = 1
Release Criteria	The unit will release the alarm when any of the following are true: <ul style="list-style-type: none"> • Number of Fans $<$ Fan X • Fan X Modbus Address D011 LSB bit 1 = 0
Troubleshooting	<ul style="list-style-type: none"> • Check power supply to unit • Contact BAC Support
General Alarm DO	True
Effect	N/A

Table 136. Fan X Phase Failure Alarm

Fan Alarms & Troubleshooting, BAC Part Number 251317

Fan alarms and troubleshooting recommendations for BAC fan part number 251317 are listed in **Table 137** through **Table 148**. Fan alarm codes are listed in **Table 150**. Refer to section **Fan Types** on **Page 33** for more information on how to identify fan type and part number.

Parameter	Condition
Trigger Criteria	The unit will issue the alarm when all the following are true: <ul style="list-style-type: none"> • Number of Fans \geq Fan X • Fan X times out Modbus communications
Release Criteria	The unit will release the alarm when any of the following are true: <ul style="list-style-type: none"> • Number of Fans $<$ Fan X • Fan X regains Modbus communications
Troubleshooting	Check Fan X's circuit breaker in control panel
General Alarm DO	True
Effect	N/A

Table 137. Fan X Offline Alarm

Parameter	Condition
Trigger Criteria	The unit will issue the alarm when all the following are true: <ul style="list-style-type: none"> • Number of Fans \geq Fan X • Fan X Modbus Address 0300 byte 1 bit 2 = 1
Release Criteria	The unit will release the alarm when any of the following are true: <ul style="list-style-type: none"> • Number of Fans $<$ Fan X • Fan X Modbus Address 0300 byte 1 bit 2 = 0
Troubleshooting	Check power supply to unit
General Alarm DO	True
Effect	N/A

Table 138. Fan X DC-link Undervoltage Alarm

Parameter	Condition
Trigger Criteria	The unit will issue the alarm when all the following are true: <ul style="list-style-type: none"> • Number of Fans \geq Fan X • Fan X Modbus Address 0300 byte 1 bit 7 = 1
Release Criteria	The unit will release the alarm when any of the following are true: <ul style="list-style-type: none"> • Number of Fans $<$ Fan X • Fan X Modbus Address 0300 byte 1 bit 7 = 0
Troubleshooting	Contact your BAC Representative for support
General Alarm DO	True
Effect	N/A

Table 139. Fan X Speed Limit Exceeded Alarm

Parameter	Condition
Trigger Criteria	The unit will issue the alarm when all the following are true: <ul style="list-style-type: none"> • Number of Fans \geq Fan X • Fan X Modbus Address 0300 byte 1 bit 4 = 1
Release Criteria	The unit will release the alarm when any of the following are true: <ul style="list-style-type: none"> • Number of Fans $<$ Fan X • Fan X Modbus Address 0300 byte 1 bit 4 = 0
Troubleshooting	Inspect Fan X and ensure there are no obstructions
General Alarm DO	True
Effect	N/A

Table 140. Fan X Motor Blocked Alarm

Parameter	Condition
Trigger Criteria	The unit will issue the alarm when all the following are true: <ul style="list-style-type: none"> • Number of Fans \geq Fan X • Fan X Modbus Address 0300 byte 1 bit 5 = 1
Release Criteria	The unit will release the alarm when any of the following are true: <ul style="list-style-type: none"> • Number of Fans $<$ Fan X • Fan X Modbus Address 0300 byte 1 bit 5 = 0
Troubleshooting	Contact your BAC Representative for support
General Alarm DO	True
Effect	N/A

Table 141. Fan X Motor Overheating Alarm

Parameter	Condition
Trigger Criteria	The unit will issue the alarm when all the following are true: <ul style="list-style-type: none"> • Number of Fans \geq Fan X • Fan X Modbus Address 0300 byte 1 bit 11 = 1
Release Criteria	The unit will release the alarm when any of the following are true: <ul style="list-style-type: none"> • Number of Fans $<$ Fan X • Fan X Modbus Address 0300 byte 1 bit 11 = 0
Troubleshooting	<ul style="list-style-type: none"> • Check Fan X communication wiring • Check Fan X communication shielding
General Alarm DO	True
Effect	N/A

Table 142. Fan X Communication Error Alarm

Parameter	Condition
Trigger Criteria	The unit will issue the alarm when all the following are true: <ul style="list-style-type: none"> • Number of Fans \geq Fan X • Fan X Modbus Address 0300 byte 1 bit 3 = 1
Release Criteria	The unit will release the alarm when any of the following are true: <ul style="list-style-type: none"> • Number of Fans $<$ Fan X • Fan X Modbus Address 0300 byte 1 bit 3 = 0
Troubleshooting	<ul style="list-style-type: none"> • Check power supply to unit • Contact BAC Support
General Alarm DO	True
Effect	N/A

Table 143. Fan X Phase Failure Alarm

Parameter	Condition
Trigger Criteria	The unit shall issue the alarm when any of the following are true: <ul style="list-style-type: none"> • Number of Fans \geq Fan X • Fan X Modbus Address 0300 byte 1 bit 0 = 1
Release Criteria	The unit shall release the alarm when any of the following is true: <ul style="list-style-type: none"> • Number of Fans $<$ Fan X • Fan X Modbus Address 0300 byte 1 bit 0 = 0
Troubleshooting	Contact BAC Support
General Alarm DO	True
Effect	N/A

Table 144. Fan X Over Current Alarm

Parameter	Condition
Trigger Criteria	The unit shall issue the alarm when any of the following are true: <ul style="list-style-type: none"> • Number of Fans \geq Fan X • Fan X Modbus Address 0300 byte 1 bit 1 = 1
Release Criteria	The unit shall release the alarm when any of the following is true: <ul style="list-style-type: none"> • Number of Fans $<$ Fan X • Fan X Modbus Address 0300 byte 1 bit 1 = 0
Troubleshooting	Contact BAC Support
General Alarm DO	True
Effect	N/A

Table 145. Fan X Over Voltage Alarm

Parameter	Condition
Trigger Criteria	The unit shall issue the alarm when any of the following are true: <ul style="list-style-type: none"> • Number of Fans \geq Fan X • Fan X Modbus Address 0300 byte 1 bit 9 = 1
Release Criteria	The unit shall release the alarm when any of the following is true: <ul style="list-style-type: none"> • Number of Fans $<$ Fan X • Fan X Modbus Address 0300 byte 1 bit 9 = 0
Troubleshooting	Contact BAC Support
General Alarm DO	True
Effect	N/A

Table 146. Fan X Watchdog Failure Alarm

Parameter	Condition
Trigger Criteria	The unit shall issue the alarm when any of the following are true: <ul style="list-style-type: none"> • Number of Fans \geq Fan X • Fan X Modbus Address 0300 byte 1 bit 10 = 1
Release Criteria	The unit shall release the alarm when any of the following is true: <ul style="list-style-type: none"> • Number of Fans $<$ Fan X • Fan X Modbus Address 0300 byte 1 bit 10 = 0
Troubleshooting	Contact BAC Support
General Alarm DO	True
Effect	N/A

Table 147. Fan X Hardware Overcurrent Alarm

Parameter	Condition
Trigger Criteria	The unit shall issue the alarm when any of the following are true: <ul style="list-style-type: none"> • Number of Fans \geq Fan X • Fan X Modbus Address 0300 byte 2 bit 1 = 1
Release Criteria	The unit shall release the alarm when any of the following is true: <ul style="list-style-type: none"> • Number of Fans $<$ Fan X • Fan X Modbus Address 0300 byte 2 bit 1 = 0
Troubleshooting	Contact BAC Support
General Alarm DO	True
Effect	N/A

Table 148. Fan X MCdsp Dead Alarm

Unit Alarm Codes

Unit Alarm codes listed in **Table 149** are enumerations porting a number code to a specific alarm. These codes are used in the Data logging and BMS communications to effectively communicate active alarms.

Alarm Code	Unit Alarm
0	No Alarm
1	Pump 1 No Current
2	Pump 1 Lock Out
3	Pump 2 No Current
4	Pump 2 Lock Out
5	Low Leaving Fluid Temperature
6	Low Basin Water
7	High Basin Water
8	Drain Valve Alarm
9	Make Up 1 Alarm
10	Make Up 2 Alarm
11	Water Supply Alarm
12	Leaving Fluid Temperature Sensor Alarm
13	Outside Air Temperature Sensor Alarm
14	All Fans Offline/E-Stop Alarm
15	Low Level Float Alarm
16	Mid Level Float Alarm
17	Low Customer Input Current
18	High Leaving Fluid Temperature

Table 149. Unit Alarm Codes

Fan Alarm Codes

Fan Alarm codes listed in **Table 150** are enumerations porting a number code to a specific alarm. These codes are used in the Data logging and BMS communications to effectively communicate active alarms.

Fan Number																		Fan Alarm
1	2	3	4	5	6	7	8	9	10	11	12	13	14	15	16	17	18	
Fan Alarm Code																		
0	0	0	0	0	0	0	0	0	0	0	0	0	0	0	0	0	0	No Fan Alarm
1	12	23	34	45	56	67	78	89	100	111	122	133	144	155	166	177	188	Fan X Offline
2	13	24	35	46	57	68	79	90	101	112	123	134	145	156	167	178	189	Fan X DC-link Undervoltage
3	14	25	36	47	58	69	80	91	102	113	124	135	146	157	168	179	190	Fan X Position Sensor Cal Error
4	15	26	37	48	59	70	81	92	103	114	125	136	147	158	169	180	191	Fan X Speed Limit Exceeded
5	16	27	38	49	60	71	82	93	104	115	126	137	148	159	170	181	192	Fan X Motor Blocked
6	17	28	39	50	61	72	83	94	105	116	127	138	149	160	171	182	193	Fan X Hall Sensor Error
7	18	29	40	51	62	73	84	95	106	117	128	139	150	161	172	183	194	Fan X Motor Overheating
8	19	30	41	52	63	74	85	96	107	118	129	140	151	162	173	184	195	Fan X Fan Bad (General Error)
9	20	31	42	53	64	75	86	97	108	119	130	141	152	163	174	185	196	Fan X Communication Error
10	21	32	43	54	65	76	87	98	109	120	131	142	153	164	175	186	197	Fan X Output Stage Overheating
11	22	33	44	55	66	77	88	99	110	121	132	143	154	165	176	187	198	Fan X Phase Failure
199	204	209	214	219	224	229	234	239	244	249	254	259	264	269	274	279	284	Fan X Over Current
200	205	210	215	220	225	230	235	240	245	250	255	260	265	270	275	280	285	Fan X Over Voltage
201	206	211	216	221	226	231	236	241	246	251	256	261	266	271	276	281	286	Fan X Watchdog Failure
202	207	212	217	222	227	232	237	242	247	252	257	262	267	272	277	282	287	Fan X Hardware Overcurrent
203	208	213	218	223	228	233	238	243	248	253	258	263	268	273	278	283	288	Fan X MCdsp Dead

Table 150. Fan Alarm Codes

Appendix D – Points List Part #313976

Modbus RTU Communications, Points List

Table 151. Modbus RTU Communications, Points List						
Variable	Description	R/W	Data Type	Low Limit	High Limit	Modbus RTU Registers
Year	Current Year in YYYY format	R	A			30001
Month	Current Month in MM format	R	A			30002
Day	Current Day in DD format	R	A			30003
Hour	Current Hour in HH format	R	A			30004
Minute	Current Minute in MM format	R	A			30005
Second	Current Second in SS format	R	A			30006
LFT	Leaving Fluid Temperature in x10 format [°C]	R	A			30007
LFTsetp	Leaving Fluid Temperature Setpoint in x10 format [°C]	W	A	4.4	50	42049
CtrlRange	Control Range in x10 format [°C]	W	A	0.5	5.5	42050
AdiabaticSP	Adiabatic Switchpoint in x10 format [°C]	W	A	5	50	42051
OAT	Outside Air Temperature in x10 format [°C]	R	A			30008
BMSrunEn	BMS Run Enable 0 = Off 1 = On	W	B			2849
RunStatus	Trillium Run Status 0 = Not Running 1 = Running	R	B			12401
WaterDisable	Water Usage Disable. Forces the unit into dry mode 0 = Water Usage Enabled 1 = Water Usage Disabled	W	B			2850
FanSpdCmd	Fan Speed Command in x10 format [% max fan speed]	R	A			30009

Table 151. Modbus RTU Communications, Points List

Variable	Description	R/W	Data Type	Low Limit	High Limit	Modbus RTU Registers
ActlFanSpd	Average Fan Speed Feedback in x10 format [%]	R	A			30010
ActlFanSpdRPM	Average Fan Speed Feedback in x10 format [RPM]	R	A			30011
CIFanCMD	Customer Input Fan Command (0.0 -100.0) [% Max Fan Speed] in x10 format Only valid if configured for Customer Input mode, type BMS	W	A	0	100	42052
OpMode	Operating Mode 0 = Undefined 1 = Default 2 = Energy Saver 3 = Water Saver	W	A	1	3	42053
UnitMode	Control State (from State Machine) 0 = Undefined 1 = Off 2 = Manual 3 = Dry 4 = Single Precooler 5 = Dual Precooler 6 = Coil Clean 7 = Pad Cleaning 8 = Drain and Dry 9 = Wet Coil Clean 10 = Emergency	R	A			30012
Precooler1Status	Precooler 1 status 0 = Lead 1 = Lag	R	B			12402
Precooler2Status	Precooler 2 status 0 = Lead 1 = Lag	R	B			12403
Pump1cmd	Pump 1 Command 0 = Off 1 = On	R	B			12404
Pump2cmd	Pump 2 Command 0 = Off 1 = On	R	B			12405

Table 151. Modbus RTU Communications, Points List

Variable	Description	R/W	Data Type	Low Limit	High Limit	Modbus RTU Registers
Pump1status	Pump 1 Status 0 = No Pump Current Detected 1 = Pump Current Detected	R	B			12406
Pump2status	Pump 2 Status 0 = No Pump Current Detected 1 = Pump Current Detected	R	B			12407
MUP1cmd	Make Up Valve 1 Command 0 = Closed 1 = Open	R	B			12408
MUP2cmd	Make Up Valve 2 Command 0 = Closed 1 = Open	R	B			12409
DrainValveCmd	Drain Valve Command 0 = Open 1 = Closed	R	B			12410
LLF	Low Level Float Status 0 = Water Level below Float 1 = Water Level above Float	R	B			12411
MLF	Mid Level Float Status 0 = Water Level below Float 1 = Water Level above Float	R	B			12412
HLF	High Level Float Status 0 = Water Level below Float 1 = Water Level above Float	R	B			12413
Precooler1Starts	Precooler 1 number of starts	R	A			30013
Precooler1Hrs	Precooler 1 run hours	R	A			30014
Precooler2Starts	Precooler 2 number of starts	R	A			30015
Precooler2Hrs	Precooler 2 run hours	R	A			30016
Precooler1Temp	Precooler 1 Temperature in x10 format [°C]	R	A			30126

Table 151. Modbus RTU Communications, Points List

Variable	Description	R/W	Data Type	Low Limit	High Limit	Modbus RTU Registers
Precooler2Temp	Precooler 2 Temperature in x10 format [°C]	R	A			30127
EFT	Entering Fluid Temperature in x10 format [°C]	R	A			30128
OARH	Outside Air Relative Humidity in x10 format [%]	R	A			30129
Pump1Starts	Pump 1 number of starts	R	A			30017
Pump1Hrs	Pump 1 run hours [hours]	R	A			30018
Pump1ARtimer	Pump 1 Anti-Recycle Timer 0 = Inactive 1 = Active	R	B			12414
Pump2Starts	Pump 2 number of starts	R	A			30019
Pump2Hrs	Pump 2 run hours [hours]	R	A			30020
Pump2ARtimer	Pump 2 Anti-Recycle Timer 0 = Inactive 1 = Active	R	B			12415
MUP1starts	Make Up Valve 1 starts	R	A			30021
MUP1hrs	Make Up Valve 1 run hours [hours]	R	A			30022
MUP2starts	Make Up Valve 2 starts	R	A			30023
MUP2hrs	Make Up Valve 2 run hours [hours]	R	A			30024
DrainVlvStarts	Drain Valve starts	R	A			30025
DrainVlvHrs	Drain Valve run hours [hours]	R	A			30026
BasinRetentionTime	Basin Retention Time [hours] The amount of time in Dry mode that the unit will hold the basin water before dumping.	R	A	6	72	30027
NumCoCs	Number of Cycles of Concentration till Basin drain	R	A	1	10	30028

Table 151. Modbus RTU Communications, Points List

Variable	Description	R/W	Data Type	Low Limit	High Limit	Modbus RTU Registers
NightDryOverride	Night Dry Feature Override 0 = Auto 1 = Override	W	B			2851
NightDrySunStart	Night Dry Schedule Sunday Start time in HHMM format	W	A	0	2359	42055
NightDryMonStop	Night Dry Schedule Monday Stop time in HHMM format	W	A	0	2359	42056
NightDryMonStart	Night Dry Schedule Monday Start time in HHMM format	W	A	0	2359	42057
NightDryTueStop	Night Dry Schedule Tuesday Stop time in HHMM format	W	A	0	2359	42058
NightDryTueStart	Night Dry Schedule Tuesday Start time in HHMM format	W	A	0	2359	42059
NightDryWedStop	Night Dry Schedule Wednesday Stop time in HHMM format	W	A	0	2359	42060
NightDryWedStart	Night Dry Schedule Wednesday Start time in HHMM format	W	A	0	2359	42061
NightDryThuStop	Night Dry Schedule Thursday Stop time in HHMM format	W	A	0	2359	42062
NightDryThuStart	Night Dry Schedule Thursday Start time in HHMM format	W	A	0	2359	42063
NightDryFriStop	Night Dry Schedule Friday Stop time in HHMM format	W	A	0	2359	42064
NightDryFriStart	Night Dry Schedule Friday Start time in HHMM format	W	A	0	2359	42065
NightDrySatStop	Night Dry Schedule Saturday Stop time in HHMM format	W	A	0	2359	42066
NightDrySatStart	Night Dry Schedule Saturday Start time in HHMM format	W	A	0	2359	42067
NightDrySunStop	Night Dry Schedule Sunday Stop time in HHMM format	W	A	0	2359	42068

Table 151. Modbus RTU Communications, Points List

Variable	Description	R/W	Data Type	Low Limit	High Limit	Modbus RTU Registers
ScheduleDryOverride	Schedule Dry Feature Override 0 = Auto 1 = Override	W	B			2852
ScheduleDrySunStart	Schedule Dry Schedule Sunday Start time in HHMM format	W	A	0	2359	42069
ScheduleDrySunStop	Schedule Dry Schedule Sunday Stop time in HHMM format	W	A	0	2359	42070
ScheduleDryMonStart	Schedule Dry Schedule Monday Start time in HHMM format	W	A	0	2359	42071
ScheduleDryMonStop	Schedule Dry Schedule Monday Stop time in HHMM format	W	A	0	2359	42072
ScheduleDryTueStart	Schedule Dry Schedule Tuesday Start time in HHMM format	W	A	0	2359	42073
ScheduleDryTueStop	Schedule Dry Schedule Tuesday Stop time in HHMM format	W	A	0	2359	42074
ScheduleDryWedStart	Schedule Dry Schedule Wednesday Start time in HHMM format	W	A	0	2359	42075
ScheduleDryWedStop	Schedule Dry Schedule Wednesday Stop time in HHMM format	W	A	0	2359	42076
ScheduleDryThuStart	Schedule Dry Schedule Thursday Start time in HHMM format	W	A	0	2359	42077
ScheduleDryThuStop	Schedule Dry Schedule Thursday Stop time in HHMM format	W	A	0	2359	42078
ScheduleDryFriStart	Schedule Dry Schedule Friday Start time in HHMM format	W	A	0	2359	42079
ScheduleDryFriStop	Schedule Dry Schedule Friday Stop time in HHMM format	W	A	0	2359	42080
ScheduleDrySatStart	Schedule Dry Schedule Saturday Start time in HHMM format	W	A	0	2359	42081
ScheduleDrySatStop	Schedule Dry Schedule Saturday Stop time in HHMM format	W	A	0	2359	42082

Table 151. Modbus RTU Communications, Points List

Variable	Description	R/W	Data Type	Low Limit	High Limit	Modbus RTU Registers
NightQuietOverride	Night Quiet Feature Override 0 = Auto 1 = Override	W	B			2853
NightQuietLim	Night Quiet Limit in x10 format [% max fan speed]	W	A	0	100	42083
NightQuietAdiaSP	Night Quiet Adiabatic Switchpoint in x10 format [°C]	W	A	5		42084
NightQuietSunStart	Night Quiet Schedule Sunday Start time in HHMM format	W	A	0	2359	42085
NightQuietMonStop	Night Quiet Schedule Monday Stop time in HHMM format	W	A	0	2359	42086
NightQuietMonStart	Night Quiet Schedule Monday Start time in HHMM format	W	A	0	2359	42087
NightQuietTueStop	Night Quiet Schedule Tuesday Stop time in HHMM format	W	A	0	2359	42088
NightQuietTueStart	Night Quiet Schedule Tuesday Start time in HHMM format	W	A	0	2359	42089
NightQuietWedStop	Night Quiet Schedule Wednesday Stop time in HHMM format	W	A	0	2359	42090
NightQuietWedStart	Night Quiet Schedule Wednesday Start time in HHMM format	W	A	0	2359	42091
NightQuietThuStop	Night Quiet Schedule Thursday Stop time in HHMM format	W	A	0	2359	42092
NightQuietThuStart	Night Quiet Schedule Thursday Start time in HHMM format	W	A	0	2359	42093
NightQuietFriStop	Night Quiet Schedule Friday Stop time in HHMM format	W	A	0	2359	42094
NightQuietFriStart	Night Quiet Schedule Friday Start time in HHMM format	W	A	0	2359	42095
NightQuietSatStop	Night Quiet Schedule Saturday Stop time in HHMM format	W	A	0	2359	42096

Table 151. Modbus RTU Communications, Points List

Variable	Description	R/W	Data Type	Low Limit	High Limit	Modbus RTU Registers
NightQuietSatStart	Night Quiet Schedule Saturday Start time in HHMM format	W	A	0	2359	42097
NightQuietSunStop	Night Quiet Schedule Sunday Stop time in HHMM format	W	A	0	2359	42098
PadCleanOverride	Pad Cleaning Override Use this point to force a pad clean cycle 0 = Disable 1 = Override	W	B			2854
CoilCleanOverride	Coil Cleaning Override Use this point to force a coil clean cycle 0 = Disable 1 = Override	W	B			2855
DrainDryOverride	Complete Drain and Dry Override Use this point to force a drain and dry cycle 0 = Disable 1 = Override	W	B			2856
NightDryEn	Night Dry feature Enable 0 = Disabled 1 = Enable	W	B			2857
ScheduleDryEn	Schedule Dry feature Enable 0 = Disabled 1 = Enable	W	B			2858
NightQuietEn	Night Quiet feature Enable 0 = Disabled 1 = Enable	W	B			2859
AlarmCode	Unit Alarm Code See Table 65 and Table 66	R	A			30029
FanAlarmCode	Fan Alarm Code See Table 67	R	A			30030
AvgFanActISpd	Average Fan Speed Feedback in x10 format [RPM]	R	A			30031
AvgFanPwr	Average Fan Power in x10 format [kW]	R	A			30032
AvgFanCurr	Average Fan Current in x10 format [A]	R	A			30033

Table 151. Modbus RTU Communications, Points List

Variable	Description	R/W	Data Type	Low Limit	High Limit	Modbus RTU Registers
Fan1status	Fan 1 status 0 = Disabled/Offline 1 = Normal 2 = Alarm	R	A			30034
Fan1ActlSpd	Fan 1 Speed Feedback in x10 format [RPM]	R	A			30035
Fan1Pwr	Fan 1 Power in x10 format [kW]	R	A			30036
Fan1Curr	Fan 1 Current in x10 format [A]	R	A			30037
Fan1Hrs	Fan 1 run hours [hours]	R	A			30038
Fan2status	Fan 2 status 0 = Disabled/Offline 1 = Normal 2 = Alarm	R	A			30039
Fan2ActlSpd	Fan 2 Speed Feedback in x10 format [RPM]	R	A			30040
Fan2Pwr	Fan 2 Power in x10 format [kW]	R	A			30041
Fan2Curr	Fan 2 Current in x10 format [A]	R	A			30042
Fan2Hrs	Fan 2 run hours [hours]	R	A			30043
Fan3status	Fan 3 status 0 = Disabled/Offline 1 = Normal 2 = Alarm	R	A			30044
Fan3ActlSpd	Fan 3 Speed Feedback in x10 format [RPM]	R	A			30045
Fan3Pwr	Fan 3 Power in x10 format [kW]	R	A			30046
Fan3Curr	Fan 3 Current in x10 format [A]	R	A			30047
Fan3Hrs	Fan 3 run hours [hours]	R	A			30048
Fan4status	Fan 4 status 0 = Disabled/Offline 1 = Normal 2 = Alarm	R	A			30049
Fan4ActlSpd	Fan 4 Speed Feedback in x10 format [RPM]	R	A			30050
Fan4Pwr	Fan 4 Power in x10 format [kW]	R	A			30051
Fan4Curr	Fan 4 Current in x10 format [A]	R	A			30052

Table 151. Modbus RTU Communications, Points List

Variable	Description	R/W	Data Type	Low Limit	High Limit	Modbus RTU Registers
Fan4Hrs	Fan 4 run hours [hours]	R	A			30053
Fan5status	Fan 5 status 0 = Disabled/Offline 1 = Normal 2 = Alarm	R	A			30054
Fan5ActlSpd	Fan 5 Speed Feedback in x10 format [RPM]	R	A			30055
Fan5Pwr	Fan 5 Power in x10 format [kW]	R	A			30056
Fan5Curr	Fan 5 Current in x10 format [A]	R	A			30057
Fan5Hrs	Fan 5 run hours [hours]	R	A			30058
Fan6status	Fan 6 status 0 = Disabled/Offline 1 = Normal 2 = Alarm	R	A			30059
Fan6ActlSpd	Fan 6 Speed Feedback in x10 format [RPM]	R	A			30060
Fan6Pwr	Fan 6 Power in x10 format [kW]	R	A			30061
Fan6Curr	Fan 6 Current in x10 format [A]	R	A			30062
Fan6Hrs	Fan 6 run hours [hours]	R	A			30063
Fan7status	Fan 7 status 0 = Disabled/Offline 1 = Normal 2 = Alarm	R	A			30064
Fan7ActlSpd	Fan 7 Speed Feedback in x10 format [RPM]	R	A			30065
Fan7Pwr	Fan 7 Power in x10 format [kW]	R	A			30066
Fan7Curr	Fan 7 Current in x10 format [A]	R	A			30067
Fan7Hrs	Fan 7 run hours [hours]	R	A			30068
Fan8status	Fan 8 status 0 = Disabled/Offline 1 = Normal 2 = Alarm	R	A			30069
Fan8ActlSpd	Fan 8 Speed Feedback in x10 format [RPM]	R	A			30070
Fan8Pwr	Fan 8 Power in x10 format [kW]	R	A			30071

Table 151. Modbus RTU Communications, Points List

Variable	Description	R/W	Data Type	Low Limit	High Limit	Modbus RTU Registers
Fan8Curr	Fan 8 Current in x10 format [A]	R	A			30072
Fan8Hrs	Fan 8 run hours [hours]	R	A			30073
Fan9status	Fan 9 status 0 = Disabled/Offline 1 = Normal 2 = Alarm	R	A			30074
Fan9ActlSpd	Fan 9 Speed Feedback in x10 format [RPM]	R	A			30075
Fan9Pwr	Fan 9 Power in x10 format [kW]	R	A			30076
Fan9Curr	Fan 9 Current in x10 format [A]	R	A			30077
Fan9Hrs	Fan 9 run hours [hours]	R	A			30078
Fan10status	Fan 10 status 0 = Disabled/Offline 1 = Normal 2 = Alarm	R	A			30079
Fan10ActlSpd	Fan 10 Speed Feedback in x10 format [RPM]	R	A			30080
Fan10Pwr	Fan 10 Power in x10 format [kW]	R	A			30081
Fan10Curr	Fan 10 Current in x10 format [A]	R	A			30082
Fan10Hrs	Fan 10 run hours [hours]	R	A			30083
Fan11status	Fan 11 status 0 = Disabled/Offline 1 = Normal 2 = Alarm	R	A			30084
Fan11ActlSpd	Fan 11 Speed Feedback in x10 format [RPM]	R	A			30085
Fan11Pwr	Fan 11 Power in x10 format [kW]	R	A			30086
Fan11Curr	Fan 11 Current in x10 format [A]	R	A			30087
Fan11Hrs	Fan 11 run hours [hours]	R	A			30088
Fan12status	Fan 12 status 0 = Disabled/Offline 1 = Normal 2 = Alarm	R	A			30089
Fan12ActlSpd	Fan 12 Speed Feedback in x10 format [RPM]	R	A			30090

Table 151. Modbus RTU Communications, Points List

Variable	Description	R/W	Data Type	Low Limit	High Limit	Modbus RTU Registers
Fan12Pwr	Fan 12 Power in x10 format [kW]	R	A			30091
Fan12Curr	Fan 12 Current in x10 format [A]	R	A			30092
Fan12Hrs	Fan 12 run hours [hours]	R	A			30093
Fan13status	Fan 13 status 0 = Disabled/Offline 1 = Normal 2 = Alarm	R	A			30094
Fan13ActlSpd	Fan 13 Speed Feedback in x10 format [RPM]	R	A			30095
Fan13Pwr	Fan 13 Power in x10 format [kW]	R	A			30096
Fan13Curr	Fan 13 Current in x10 format [A]	R	A			30097
Fan13Hrs	Fan 13 run hours [hours]	R	A			30098
Fan14status	Fan 14 status 0 = Disabled/Offline 1 = Normal 2 = Alarm	R	A			30099
Fan14ActlSpd	Fan 14 Speed Feedback in x10 format [RPM]	R	A			30100
Fan14Pwr	Fan 14 Power in x10 format [kW]	R	A			30101
Fan14Curr	Fan 14 Current in x10 format [A]	R	A			30102
Fan14Hrs	Fan 14 run hours [hours]	R	A			30103
Fan15status	Fan 15 status 0 = Disabled/Offline 1 = Normal 2 = Alarm	R	A			30104
Fan15ActlSpd	Fan 15 Speed Feedback in x10 format [RPM]	R	A			30105
Fan15Pwr	Fan 15 Power in x10 format [kW]	R	A			30106
Fan15Curr	Fan 15 Current in x10 format [A]	R	A			30107
Fan15Hrs	Fan 15 run hours [hours]	R	A			30108
Fan16status	Fan 16 status 0 = Disabled/Offline 1 = Normal 2 = Alarm	R	A			30109

Table 151. Modbus RTU Communications, Points List

Variable	Description	R/W	Data Type	Low Limit	High Limit	Modbus RTU Registers
Fan16ActlSpd	Fan 16 Speed Feedback in x10 format [RPM]	R	A			30110
Fan16Pwr	Fan 16 Power in x10 format [kW]	R	A			30111
Fan16Curr	Fan 16 Current in x10 format [A]	R	A			30112
Fan16Hrs	Fan 16 run hours [hours]	R	A			30113
Fan17status	Fan 17 status 0 = Disabled/Offline 1 = Normal 2 = Alarm	R	A			30114
Fan17ActlSpd	Fan 17 Speed Feedback in x10 format [RPM]	R	A			30115
Fan17Pwr	Fan 17 Power in x10 format [kW]	R	A			30116
Fan17Curr	Fan 17 Current in x10 format [A]	R	A			30117
Fan17Hrs	Fan 17 run hours [hours]	R	A			30118
Fan18status	Fan 18 status 0 = Disabled/Offline 1 = Normal 2 = Alarm	R	A			30119
Fan18ActlSpd	Fan 18 Speed Feedback in x10 format [RPM]	R	A			30120
Fan18Pwr	Fan 18 Power in x10 format [kW]	R	A			30121
Fan18Curr	Fan 18 Current in x10 format [A]	R	A			30122
Fan18Hrs	Fan 18 run hours [hours]	R	A			30123

Table 151. Modbus RTU Communications, Points List

BACnet Communications, Points List

Table 152. BACnet Communications, Points List

Point Name	Description	Data Type	Low Limit	High Limit	BACnet Address
Year	Current Year in YYYY format	Float			AI1
Month	Current Month in MM format	Float			AI2
Day	Current Day in DD format	Float			AI3
Hour	Current Hour in HH format	Float			AI4
Minute	Current Minute in MM format	Float			AI5
Second	Current Second in SS format	Float			AI6
LFT	Leaving Fluid Temperature [°C]	Float			AI7
LFTsetp	Leaving Fluid Temperature Setpoint [°C]	Float	4.4	50	AV1
CtrlRange	Control Range [°C]	Float	0.5	5.5	AV2
AdiabaticSP	Adiabatic Switchpoint [°C]	Float	5	50	AV3
OAT	Outside Air Temperature [°C]	Float			AI8
BMSrunEn	BMS Run Enable 0 = Off 1 = On	Bool			BV1
RunStatus	Trillium Run Status 0 = Not Running 1 = Running	Bool			BV2
WaterDisable	Water Usage Disable. Forces the unit into dry mode 0 = Water Usage Enabled 1 = Water Usage Disabled	Bool			BV3
FanSpdCmd	Fan Speed Command [% max fan speed]	Float			AI9
ActlFanSpd	Average Fan Speed Feedback [%]	Float			AI10
ActlFanSpdRPM	Average Fan Speed Feedback [RPM]	Float			AI11
CIFanCMD	Customer Input Fan Command (0.0 -100.0) [% Max Fan Speed] Only valid if configured for Customer Input mode, type BMS	Float	0	100	AV4
OpMode	Operating Mode 1 = Undefined 2 = Default 3 = Energy Saver 4 = Water Saver	UDINT	1	3	MSV1

Table 152. BACnet Communications, Points List

Point Name	Description	Data Type	Low Limit	High Limit	BACnet Address
UnitMode	Control State (from State Machine) 1 = Undefined 2 = Off 3 = Manual 4 = Dry 5 = Single Precooler 6 = Dual Precooler 7 = Coil Clean 8 = Pad Cleaning 9 = Drain and Dry 10 = Wet Coil Clean 11 = Emergency	UDIN T			MSO1
Precooler1Status	Precooler 1 status 1 = Lead 2 = Lag	UDIN T			MSO2
Precooler2Status	Precooler 2 status 1 = Lead 2 = Lag	UDIN T			MSO3P
Pump1cmd	Pump 1 Command 0 = Off 1 = On	Bool			BV4
Pump2cmd	Pump 2 Command 0 = Off 1 = On	Bool			BV5
Pump1status	Pump 1 Status 0 = No Pump Current Detected 1 = Pump Current Detected	Bool			BV6
Pump2status	Pump 2 Status 0 = No Pump Current Detected 1 = Pump Current Detected	Bool			BV7
MUP1cmd	Make Up Valve 1 Command 0 = Closed 1 = Open	Bool			BV8
MUP2cmd	Make Up Valve 2 Command 0 = Closed 1 = Open	Bool			BV9
DrainValveCmd	Drain Valve Command 0 = Open 1 = Closed	Bool			BV10
LLF	Low Level Float Status 0 = Water Level below Float 1 = Water Level above Float	Bool			BI1
MLF	Mid Level Float Status 0 = Water Level below Float 1 = Water Level above Float	Bool			BI2

Table 152. BACnet Communications, Points List

Point Name	Description	Data Type	Low Limit	High Limit	BACnet Address
HLF	High Level Float Status 0 = Water Level below Float 1 = Water Level above Float	Bool			BI3
Precooler1Starts	Precooler 1 number of starts	Float			AI12
Precooler1Hrs	Precooler 1 run hours	Float			AI13
Precooler2Starts	Precooler 2 number of starts	Float			AI14
Precooler2Hrs	Precooler 2 run hours	Float			AI15
Precooler1Temp	Precooler 1 Temperature [°C]	Float			AI19
Precooler2Temp	Precooler 2 Temperature [°C]	Float			AI20
EFT	Entering Fluid Temperature [°C]	Float			AI21
OARH	Outside Air Relative Humidity [%]	Float			AI22
Pump1Starts	Pump 1 number of starts	Float			AV5
Pump1Hrs	Pump 1 run hours [hours]	Float			AV6
Pump1ARtimer	Pump 1 Anti-Recycle Timer 0 = Inactive 1 = Active	Bool			BV11
Pump2Starts	Pump 2 number of starts	Float			AV7
Pump2Hrs	Pump 2 run hours [hours]	Float			AV8
Pump2ARtimer	Pump 2 Anti-Recycle Timer 0 = Inactive 1 = Active	Bool			BV12
MUP1starts	Make Up Valve 1 starts	Float			AV9
MUP1hrs	Make Up Valve 1 run hours [hours]	Float			AV10
MUP2starts	Make Up Valve 2 starts	Float			AV11
MUP2hrs	Make Up Valve 2 run hours [hours]	Float			AV12
DrainVlvStarts	Drain Valve starts	Float			AV13
DrainVlvHrs	Drain Valve run hours [hours]	Float			AV14
BasinRetentionTime	Basin Retention Time [hours] The amount of time in Dry mode that the unit will hold the basin water before dumping.	Float	6	72	AV15
NumCoCs	Number of Cycles of Concentration till Basin drain	Float	1	10	AV16
NightDryOverride	Night Dry Feature Override 0 = Auto 1 = Override	Bool			BV13
NightDrySunStart	Night Dry Schedule Sunday Start time in HHMM format	Float	0	2359	AV17
NightDryMonStop	Night Dry Schedule Monday Stop time in HHMM format	Float	0	2359	AV18
NightDryMonStart	Night Dry Schedule Monday Start time in HHMM format	Float	0	2359	AV19
NightDryTueStop	Night Dry Schedule Tuesday Stop time in HHMM format	Float	0	2359	AV20

Table 152. BACnet Communications, Points List

Point Name	Description	Data Type	Low Limit	High Limit	BACnet Address
NightDryTueStart	Night Dry Schedule Tuesday Start time in HHMM format	Float	0	2359	AV21
NightDryWedStop	Night Dry Schedule Wednesday Stop time in HHMM format	Float	0	2359	AV22
NightDryWedStart	Night Dry Schedule Wednesday Start time in HHMM format	Float	0	2359	AV23
NightDryThuStop	Night Dry Schedule Thursday Stop time in HHMM format	Float	0	2359	AV24
NightDryThuStart	Night Dry Schedule Thursday Start time in HHMM format	Float	0	2359	AV25
NightDryFriStop	Night Dry Schedule Friday Stop time in HHMM format	Float	0	2359	AV26
NightDryFriStart	Night Dry Schedule Friday Start time in HHMM format	Float	0	2359	AV27
NightDrySatStop	Night Dry Schedule Saturday Stop time in HHMM format	Float	0	2359	AV28
NightDrySatStart	Night Dry Schedule Saturday Start time in HHMM format	Float	0	2359	AV29
NightDrySunStop	Night Dry Schedule Sunday Stop time in HHMM format	Float	0	2359	AV30
ScheduleDryOverride	Schedule Dry Feature Override 0 = Auto 1 = Override	Bool			BV14
ScheduleDrySunStart	Schedule Dry Schedule Sunday Start time in HHMM format	Float	0	2359	AV31
ScheduleDrySunStop	Schedule Dry Schedule Sunday Stop time in HHMM format	Float	0	2359	AV32
ScheduleDryMonStart	Schedule Dry Schedule Monday Start time in HHMM format	Float	0	2359	AV33
ScheduleDryMonStop	Schedule Dry Schedule Monday Stop time in HHMM format	Float	0	2359	AV34
ScheduleDryTueStart	Schedule Dry Schedule Tuesday Start time in HHMM format	Float	0	2359	AV35
ScheduleDryTueStop	Schedule Dry Schedule Tuesday Stop time in HHMM format	Float	0	2359	AV36
ScheduleDryWedStart	Schedule Dry Schedule Wednesday Start time in HHMM format	Float	0	2359	AV37
ScheduleDryWedStop	Schedule Dry Schedule Wednesday Stop time in HHMM format	Float	0	2359	AV38
ScheduleDryThuStart	Schedule Dry Schedule Thursday Start time in HHMM format	Float	0	2359	AV39
ScheduleDryThuStop	Schedule Dry Schedule Thursday Stop time in HHMM format	Float	0	2359	AV40
ScheduleDryFriStart	Schedule Dry Schedule Friday Start time in HHMM format	Float	0	2359	AV41

Table 152. BACnet Communications, Points List

Point Name	Description	Data Type	Low Limit	High Limit	BACnet Address
ScheduleDryFriStop	Schedule Dry Schedule Friday Stop time in HHMM format	Float	0	2359	AV42
ScheduleDrySatStart	Schedule Dry Schedule Saturday Start time in HHMM format	Float	0	2359	AV43
ScheduleDrySatStop	Schedule Dry Schedule Saturday Stop time in HHMM format	Float	0	2359	AV44
NightQuietOverride	Night Quiet Feature Override 0 = Auto 1 = Override	Bool			BV15
NightQuietLim	Night Quiet Limit [% max fan speed]	Float	0	100	AV45
NightQuietAdiaSP	Night Quiet Adiabatic Switchpoint [°C]	Float	5		AV46
NightQuietSunStart	Night Quiet Schedule Sunday Start time in HHMM format	Float	0	2359	AV47
NightQuietMonStop	Night Quiet Schedule Monday Stop time in HHMM format	Float	0	2359	AV48
NightQuietMonStart	Night Quiet Schedule Monday Start time in HHMM format	Float	0	2359	AV49
NightQuietTueStop	Night Quiet Schedule Tuesday Stop time in HHMM format	Float	0	2359	AV50
NightQuietTueStart	Night Quiet Schedule Tuesday Start time in HHMM format	Float	0	2359	AV51
NightQuietWedStop	Night Quiet Schedule Wednesday Stop time in HHMM format	Float	0	2359	AV52
NightQuietWedStart	Night Quiet Schedule Wednesday Start time in HHMM format	Float	0	2359	AV53
NightQuietThuStop	Night Quiet Schedule Thursday Stop time in HHMM format	Float	0	2359	AV54
NightQuietThuStart	Night Quiet Schedule Thursday Start time in HHMM format	Float	0	2359	AV55
NightQuietFriStop	Night Quiet Schedule Friday Stop time in HHMM format	Float	0	2359	AV56
NightQuietFriStart	Night Quiet Schedule Friday Start time in HHMM format	Float	0	2359	AV57
NightQuietSatStop	Night Quiet Schedule Saturday Stop time in HHMM format	Float	0	2359	AV58
NightQuietSatStart	Night Quiet Schedule Saturday Start time in HHMM format	Float	0	2359	AV59
NightQuietSunStop	Night Quiet Schedule Sunday Stop time in HHMM format	Float	0	2359	AV60
PadCleanOverride	Pad Cleaning Override Use this point to force a pad clean cycle 0 = Disable 1 = Override	Bool			BV16

Table 152. BACnet Communications, Points List

Point Name	Description	Data Type	Low Limit	High Limit	BACnet Address
CoilCleanOverride	Coil Cleaning Override Use this point to force a coil clean cycle 0 = Disable 1 = Override	Bool			BV17
DrainDryOverride	Complete Drain and Dry Override Use this point to force a drain and dry cycle 0 = Disable 1 = Override	Bool			BV18
NightDryEn	Night Dry feature Enable 0 = Disabled 1 = Enable	Bool			BV19
ScheduleDryEn	Schedule Dry feature Enable 0 = Disabled 1 = Enable	Bool			BV20
NightQuietEn	Night Quiet feature Enable 0 = Disabled 1 = Enable	Bool			BV21
AlarmCode	Unit Alarm Code incremented by 1	UDIN T			MSO4
FanAlarmCode	Fan Alarm Code incremented by 1	UDIN T			MSO5
AvgFanActISpd	Average Fan Speed Feedback [RPM]	Float			AI16
AvgFanPwr	Average Fan Power [kW]	Float			AI17
AvgFanCurr	Average Fan Current [A]	Float			AI18
Fan1status	Fan 1 status 1 = Disabled/Offline 2 = Normal 3 = Alarm	UDIN T			MSO6
Fan1ActISpd	Fan 1 Speed Feedback [RPM]	Float			AV61
Fan1Pwr	Fan 1 Power [kW]	Float			AV62
Fan1Curr	Fan 1 Current [A]	Float			AV63
Fan1Hrs	Fan 1 run hours [hours]	Float			AV64
Fan2status	Fan 2 status 1 = Disabled/Offline 2 = Normal 3 = Alarm	UDIN T			MSO7
Fan2ActISpd	Fan 2 Speed Feedback [RPM]	Float			AV65
Fan2Pwr	Fan 2 Power [kW]	Float			AV66
Fan2Curr	Fan 2 Current [A]	Float			AV67
Fan2Hrs	Fan 2 run hours [hours]	Float			AV68
Fan3status	Fan 3 status 1 = Disabled/Offline 2 = Normal 3 = Alarm	UDIN T			MSO8
Fan3ActISpd	Fan 3 Speed Feedback [RPM]	Float			AV69

Table 152. BACnet Communications, Points List

Point Name	Description	Data Type	Low Limit	High Limit	BACnet Address
Fan3Pwr	Fan 3 Power [kW]	Float			AV70
Fan3Curr	Fan 3 Current [A]	Float			AV71
Fan3Hrs	Fan 3 run hours [hours]	Float			AV72
Fan4status	Fan 4 status 1 = Disabled/Offline 2 = Normal 3 = Alarm	UDIN T			MSO9
Fan4ActISpd	Fan 4 Speed Feedback [RPM]	Float			AV73
Fan4Pwr	Fan 4 Power [kW]	Float			AV74
Fan4Curr	Fan 4 Current [A]	Float			AV75
Fan4Hrs	Fan 4 run hours [hours]	Float			AV76
Fan5status	Fan 5 status 1 = Disabled/Offline 2 = Normal 3 = Alarm	UDIN T			MSO10
Fan5ActISpd	Fan 5 Speed Feedback [RPM]	Float			AV77
Fan5Pwr	Fan 5 Power [kW]	Float			AV78
Fan5Curr	Fan 5 Current [A]	Float			AV79
Fan5Hrs	Fan 5 run hours [hours]	Float			AV80
Fan6status	Fan 6 status 1 = Disabled/Offline 2 = Normal 3 = Alarm	UDIN T			MSO11
Fan6ActISpd	Fan 6 Speed Feedback [RPM]	Float			AV81
Fan6Pwr	Fan 6 Power [kW]	Float			AV82
Fan6Curr	Fan 6 Current [A]	Float			AV83
Fan6Hrs	Fan 6 run hours [hours]	Float			AV84
Fan7status	Fan 7 status 1 = Disabled/Offline 2 = Normal 3 = Alarm	UDIN T			MSO12
Fan7ActISpd	Fan 7 Speed Feedback [RPM]	Float			AV85
Fan7Pwr	Fan 7 Power [kW]	Float			AV86
Fan7Curr	Fan 7 Current [A]	Float			AV87
Fan7Hrs	Fan 7 run hours [hours]	Float			AV88
Fan8status	Fan 8 status 1 = Disabled/Offline 2 = Normal 3 = Alarm	UDIN T			MSO13
Fan8ActISpd	Fan 8 Speed Feedback [RPM]	Float			AV89
Fan8Pwr	Fan 8 Power [kW]	Float			AV90
Fan8Curr	Fan 8 Current [A]	Float			AV91
Fan8Hrs	Fan 8 run hours [hours]	Float			AV92

Table 152. BACnet Communications, Points List

Point Name	Description	Data Type	Low Limit	High Limit	BACnet Address
Fan9status	Fan 9 status 1 = Disabled/Offline 2 = Normal 3 = Alarm	UDIN T			MSO14
Fan9ActISpd	Fan 9 Speed Feedback [RPM]	Float			AV93
Fan9Pwr	Fan 9 Power [kW]	Float			AV94
Fan9Curr	Fan 9 Current [A]	Float			AV95
Fan9Hrs	Fan 9 run hours [hours]	Float			AV96
Fan10status	Fan 10 status 1 = Disabled/Offline 2 = Normal 3 = Alarm	UDIN T			MSO15
Fan10ActISpd	Fan 10 Speed Feedback [RPM]	Float			AV97
Fan10Pwr	Fan 10 Power [kW]	Float			AV98
Fan10Curr	Fan 10 Current [A]	Float			AV99
Fan10Hrs	Fan 10 run hours [hours]	Float			AV100
Fan11status	Fan 11 status 1 = Disabled/Offline 2 = Normal 3 = Alarm	UDIN T			MSO16
Fan11ActISpd	Fan 11 Speed Feedback [RPM]	Float			AV101
Fan11Pwr	Fan 11 Power [kW]	Float			AV102
Fan11Curr	Fan 11 Current [A]	Float			AV103
Fan11Hrs	Fan 11 run hours [hours]	Float			AV104
Fan12status	Fan 12 status 1 = Disabled/Offline 2 = Normal 3 = Alarm	UDIN T			MSO17
Fan12ActISpd	Fan 12 Speed Feedback [RPM]	Float			AV105
Fan12Pwr	Fan 12 Power [kW]	Float			AV106
Fan12Curr	Fan 12 Current [A]	Float			AV107
Fan12Hrs	Fan 12 run hours [hours]	Float			AV108
Fan13status	Fan 13 status 1 = Disabled/Offline 2 = Normal 3 = Alarm	UDIN T			MSO18
Fan13ActISpd	Fan 13 Speed Feedback [RPM]	Float			AV109
Fan13Pwr	Fan 13 Power [kW]	Float			AV110
Fan13Curr	Fan 13 Current [A]	Float			AV111
Fan13Hrs	Fan 13 run hours [hours]	Float			AV112

Table 152. BACnet Communications, Points List

Point Name	Description	Data Type	Low Limit	High Limit	BACnet Address
Fan14status	Fan 14 status 1 = Disabled/Offline 2 = Normal 3 = Alarm	UDIN T			MSO19
Fan14ActISpd	Fan 14 Speed Feedback [RPM]	Float			AV113
Fan14Pwr	Fan 14 Power [kW]	Float			AV114
Fan14Curr	Fan 14 Current [A]	Float			AV115
Fan14Hrs	Fan 14 run hours [hours]	Float			AV116
Fan15status	Fan 15 status 1 = Disabled/Offline 2 = Normal 3 = Alarm	UDIN T			MSO20
Fan15ActISpd	Fan 15 Speed Feedback [RPM]	Float			AV117
Fan15Pwr	Fan 15 Power [kW]	Float			AV118
Fan15Curr	Fan 15 Current [A]	Float			AV119
Fan15Hrs	Fan 15 run hours [hours]	Float			AV120
Fan16status	Fan 16 status 1 = Disabled/Offline 2 = Normal 3 = Alarm	UDIN T			MSO21
Fan16ActISpd	Fan 16 Speed Feedback [RPM]	Float			AV121
Fan16Pwr	Fan 16 Power [kW]	Float			AV122
Fan16Curr	Fan 16 Current [A]	Float			AV123
Fan16Hrs	Fan 16 run hours [hours]	Float			AV124
Fan17status	Fan 17 status 1 = Disabled/Offline 2 = Normal 3 = Alarm	UDIN T			MSO22
Fan17ActISpd	Fan 17 Speed Feedback [RPM]	Float			AV125
Fan17Pwr	Fan 17 Power [kW]	Float			AV126
Fan17Curr	Fan 17 Current [A]	Float			AV127
Fan17Hrs	Fan 17 run hours [hours]	Float			AV128
Fan18status	Fan 18 status 1 = Disabled/Offline 2 = Normal 3 = Alarm	UDIN T			MSO23
Fan18ActISpd	Fan 18 Speed Feedback [RPM]	Float			AV129
Fan18Pwr	Fan 18 Power [kW]	Float			AV130
Fan18Curr	Fan 18 Current [A]	Float			AV131
Fan18Hrs	Fan 18 run hours [hours]	Float			AV132

Table 152. BACnet Communications, Points List

TrilliumSeries™ Adiabatic Cooler - TRF

OPERATION & MAINTAINANCE MANUAL



[BaltimoreAircoil.com](https://www.BaltimoreAircoil.com)

©2024 Baltimore Aircoil Company, Inc. | 7600 Dorsey Run Road | Jessup, MD 20794 |
410.799.6200 | RGOMTRF303_R5.0